

November 5, 2018

The Board of Commissioners of Public Utilities  
Prince Charles Building  
120 Torbay Road, P.O. Box 21040  
St. John's, NL A1A 5B2

**Attention: Ms. Cheryl Blundon**  
**Director Corporate Services & Board Secretary**

Dear Ms. Blundon:

**Re: Newfoundland and Labrador Hydro ("Hydro") – Labrador Interconnected System  
Transmission Expansion Study**

Enclosed please find one original and 12 copies of Revision 1 of Hydro's Labrador Interconnected System Transmission Expansion Study ("Expansion Study"). The study has been revised to correct section reference errors on pages 17, 32, and 36. The specific changes have been shaded for ease of reference.

Should you have questions with respect to the enclosed, please contact the undersigned.

Yours truly,

**NEWFOUNDLAND AND LABRADOR HYDRO**



Shirley A. Walsh  
Senior Legal Counsel  
SAW/sk

cc: Gerard Hayes – Newfoundland Power  
Paul Coxworthy – Stewart McKelvey  
ecc: Senwung Luk – Olthuis Kleer Townshend LLP  
Denis J. Fleming – Cox & Palmer

Dennis Browne, Q.C. – Browne Fitzgerald Morgan & Avis  
Benoît Pepin – Rio Tinto  
Dean Porter – Poole Althouse



# Labrador Interconnected System Transmission Expansion Study

October 31, 2018

Revised November 5, 2018

*A Report to the Board of Commissioners of Public Utilities*







1 **Executive Summary**

2 Newfoundland and Labrador Hydro (“Hydro”) has completed a transmission expansion study  
3 (“Expansion Study”) for the Labrador Interconnected System (“LIS”). The Expansion Study  
4 includes consideration for a range of load forecasts with the objective of identifying least-cost,  
5 reliable transmission system additions that will be required for eastern and western Labrador.  
6

7 For eastern Labrador, it is confirmed that the 138 kV interconnection from Muskrat Falls to  
8 Happy Valley-Goose Bay, as proposed in Hydro’s 2018 Capital Budget Application, is the least-  
9 cost option to reliably meet the capacity requirements of the baseline forecast.  
10

11 In western Labrador, the capacity of the 230 kV transmission system is limited to 350 MW. The  
12 baseline forecast is likely to exceed 350 MW by 2019 due to forecasted loads associated with  
13 expected load increases at Wabush Mines by Tacora. Transmission system upgrades to the 46  
14 kV network that supplies Hydro Rural customers are therefore required to increase system  
15 capacity. These upgrades consist of an increase in firm transformation capacity to the Wabush  
16 Substation and the reconductoring of 46 kV transmission lines. Upgrades are also required at  
17 Wabush Terminal Station which includes the commissioning of Synchronous Condenser No. 3  
18 (“SC3”), as well as the addition of reactive support and transformer replacements. Hydro will  
19 include the required capacity upgrades for its assets in the 2020 Capital Budget Application. In  
20 the near term, Hydro will explore a commercial arrangement to accelerate the commissioning  
21 of SC3 to avoid industrial customer load curtailment in 2019.  
22

23 The Expansion Study also includes analysis of further transmission system expansion  
24 alternatives required to meet ranges of incremental load beyond the baseline forecasts. Least-  
25 cost, reliable alternatives are presented, complete with capital and lifecycle cost information.  
26

27 Considerations relating to Hydro’s Network Addition Policy are also presented. Hydro will  
28 respond to future interconnection requests for LIS customer by applying the principles outlined  
29 in its October 1, 2018 submission. Specifically, Hydro will perform a system impact study in

- 1 response to each customer request, which includes technical analysis as well as cost allocation
- 2 calculations founded on the impact of the customer request on deviation from the baseline
- 3 plans outlined in this Expansion Study. The results of these studies will be presented for review
- 4 and approval by the Board of Commissioners of Public Utilities (“Board”).

## Table of Contents

Executive Summary.....	i
1 Introduction .....	1
2 System Overview .....	3
2.1 Labrador East .....	4
2.2 Labrador West.....	6
2.3 Transmission Planning Criteria .....	9
3 Forecasts .....	10
3.1 Load Forecasts .....	10
3.1.1 Labrador East .....	11
3.1.2 Labrador West.....	12
3.2 Fuel Price Forecast .....	13
4 System Deficiencies .....	14
4.1 Transmission Line Transfer Limits to Labrador East and West.....	14
4.1.1 Labrador East .....	14
4.1.2 Labrador West.....	15
4.2 Transformation Capacity – Wabush Substation .....	17
4.3 Transmission Line Thermal Units – 46 kV System .....	18
5 Description of Alternatives .....	19
5.1 Long-Term Supply to Labrador East.....	20
5.1.1 Alternative 1: Offload L1301/L1302 .....	20
5.1.2 Alternative 2: Muskrat Falls to Happy Valley Interconnection.....	21
5.2 Long-Term Supply to Labrador West .....	23
5.2.1 Transmission System Capacity Upgrades .....	23
5.3 Wabush Substation – Capacity Upgrade .....	24
5.3.1 Alternative 1: Substation Upgrade – Two Transformers .....	24
5.3.2 Alternative 2: Substation Upgrade – Three Transformers .....	25
5.3.3 Alternative 3: Addition of 12.5kV Bus at the Wabush Terminal Station .....	26
5.3.4 Alternative 4: Addition of 12.5kV Bus at the Flora Lake Terminal Station .....	26
6 Economic Analysis of Proposed Alternatives.....	26
6.1 Results.....	27
6.1.1 Long-Term Supply to Labrador East.....	27
6.1.2 Labrador West Transmission System Capacity .....	28

6.1.3	Wabush Substation – Capacity Upgrade .....	29
7	Considerations for Additional Load Growth .....	30
7.1	Labrador East .....	30
7.2	Labrador West.....	31
7.2.1	Considerations for an Interconnection to Hydro-Québec.....	32
8	Network Addition Policy Overview .....	33
9	Customer Rate Impacts.....	34
10	Further Options for Reliability Improvement .....	34
11	Conclusion and Recommendations .....	35
11.1	Recommendations to Meet Baseline Load Requirements.....	35
11.2	Recommendations to Meet Incremental Load Requests.....	36

**List of Appendices**

- Appendix A: Future Supply of Labrador East – Phased Approach Transmission System Analysis
- Appendix B: Transmission System Analysis Future Supply of Labrador West
- Appendix C: Labrador West 46 kV System Expansion – Wabush Substation Upgrade Alternatives
- Appendix D: Labrador West 46 kV System Expansion – Existing 46 kV System and Future Alternatives
- Appendix E: Reliability Assessment of the 138 kV lines Supplying Labrador East

## 1 **1 Introduction**

2 The LIS delivers power to the majority of customers in the Happy Valley-Goose Bay area<sup>1</sup>  
3 (“Labrador East”), and the Labrador City and Wabush area (“Labrador West”). Two 230 kV lines  
4 supply power to Labrador West, while one 138 kV line delivers power to Labrador East. A map  
5 of the LIS is shown in Figure 1.

6  
7 The current transfer limits on the 230 kV and 138 kV transmission systems are 350 MW and 77  
8 MW, respectively. The 2018 Capital Budget Application for the Muskrat Falls to Happy Valley  
9 Interconnection project indicates there is an existing transmission capacity deficit on the 138 kV  
10 line to Labrador East. The demand for that area is forecasted to exceed 77 MW by January  
11 2019. The two, 230 kV transmission lines to Labrador West are inadequate to meet forecasted  
12 P90<sup>2</sup> peak loads. The P90 load forecast is expected to reach 358 MW in 2019 and 383 MW by  
13 2043. Under present operating conditions, industrial customer loads must be curtailed when  
14 loads exceed the system capacity limit of 350 MW. In the near term, Hydro will explore a  
15 commercial arrangement to accelerate the commissioning of SC3 to avoid industrial customer  
16 load curtailment in 2019.

17  
18 Given the limited available transfer capacity of the transmission systems on the LIS, Hydro  
19 completed a study of the system to determine an appropriate expansion plan that ensures a  
20 safe, reliable and economical transmission system to meet customer demands. Appendices A  
21 and B contain the analyses completed for the Labrador East and West systems, respectively. A  
22 review of the Wabush Substation, as it relates to transformation capacity, was also completed  
23 and is presented in Appendix C. Appendix D is an assessment of the 46 kV transmission network  
24 to determine upgrade requirements to meet forecasted customer demand in Wabush and  
25 Labrador City. A reliability assessment of the 138 kV lines supplying eastern Labrador is outlined  
26 in Appendix E.

---

<sup>1</sup> Happy Valley-Goose Bay area includes Happy Valley-Goose Bay, Northwest River, Sheshatshiu, and Mud Lake

<sup>2</sup> A P90 forecast is one in which the actual peak demand is expected to be below the forecast number 90% of the time and above 10% of the time.



Figure 1: Labrador Interconnected System (“LIS”)

- 1 A reliability plan has been developed for Labrador East for the 2018-2019 winter season. An  
2 interruptible load agreement has been approved, allowing Hydro to interrupt customer load  
3 during peak load conditions to reduce the power flow on the transmission system to within its  
4 capacity.<sup>3</sup> As per Hydro’s monthly Labrador East Reliability Plan updates to the Board, the  
5 following initiatives are also being undertaken:
- 6 1) back-up generation for peak loading conditions;
  - 7 2) ongoing inspections of the 138 kV transmission line;
  - 8 3) temporary restriction of new customer connections above 100 kW;
  - 9 4) improved operations protocol;
  - 10 5) enhanced customer communication initiatives; and
  - 11 6) enhancements to the Happy Valley-Goose Bay distribution system.

<sup>3</sup> As per Board Order No. P.U. 37(2018), the Interruptible Load Service Agreement is approved for the period of December 1, 2018 to March 31, 2019.

1 With respect to western Labrador, Hydro determined there is currently a requirement for  
2 additional transformation at the Wabush Substation (46/12.5 kV). The forecasted load for  
3 Wabush has exceeded the firm transformation capacity of the Wabush Substation and action is  
4 required in the near term. It was also determined that the Labrador West 46 kV transmission  
5 system requires line upgrades to accommodate a single contingency event on looped 46 kV  
6 lines. These items are anticipated to be addressed through the 2020 Capital Budget Application  
7 process.

8

## 9 **2 System Overview**

10 The LIS is an electrical grid that stretches across central Labrador from Labrador City to Happy  
11 Valley-Goose Bay and serves approximately 11,700 customers. These customers reside in major  
12 load centres and their surrounding areas. The remaining communities throughout Labrador are  
13 supplied by isolated diesel systems. From an electrical standpoint, the LIS is often divided into  
14 two separate regions - Labrador West and Labrador East, with Churchill Falls defined as the  
15 midpoint. Labrador West is the part of the LIS that is west of Churchill Falls and is comprised of  
16 Wabush and Labrador City. The LIS system east of Churchill Falls is the Labrador East System  
17 and serves Happy Valley-Goose Bay and its surrounding area. A block diagram depicting the

overall LIS is shown in Figure 2.

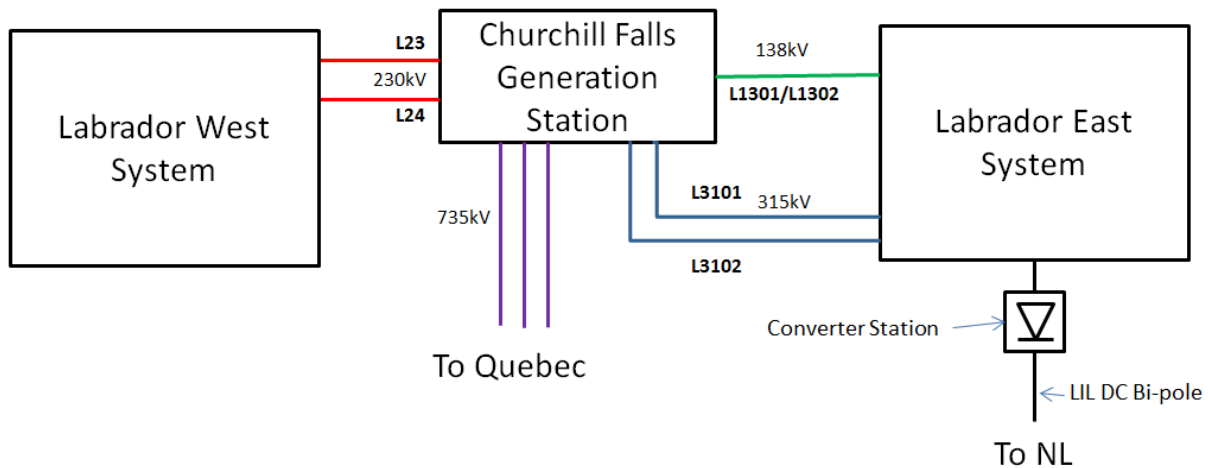

**Figure 2: Labrador Interconnected System (Block Diagram)<sup>4</sup>**

## 1 2.1 Labrador East

2 The Labrador East area is interconnected to the Churchill Falls Terminal Station via transmission  
3 lines L1301/L1302, with a total length of approximately 269 km. In 1977, transmission line  
4 L1301 was constructed to provide electricity to the Gull Island Construction Site and was  
5 extended to the town of Happy Valley-Goose Bay.<sup>5</sup> Figure 3 provides a simplified diagram of the  
6 existing Labrador East System.

<sup>4</sup> L3101 and L3102 currently deliver power to the Muskrat Falls Terminal Station No. 2 and not the Happy Valley-Goose Bay area.

<sup>5</sup> As the L1301 transmission line was planned as a temporary installation, the towers between Churchill Falls and Gull Island were not designed to Hydro standards. Rather, phase spacing was shortened to 3.2 m as opposed to the standard value of 4.3 m.



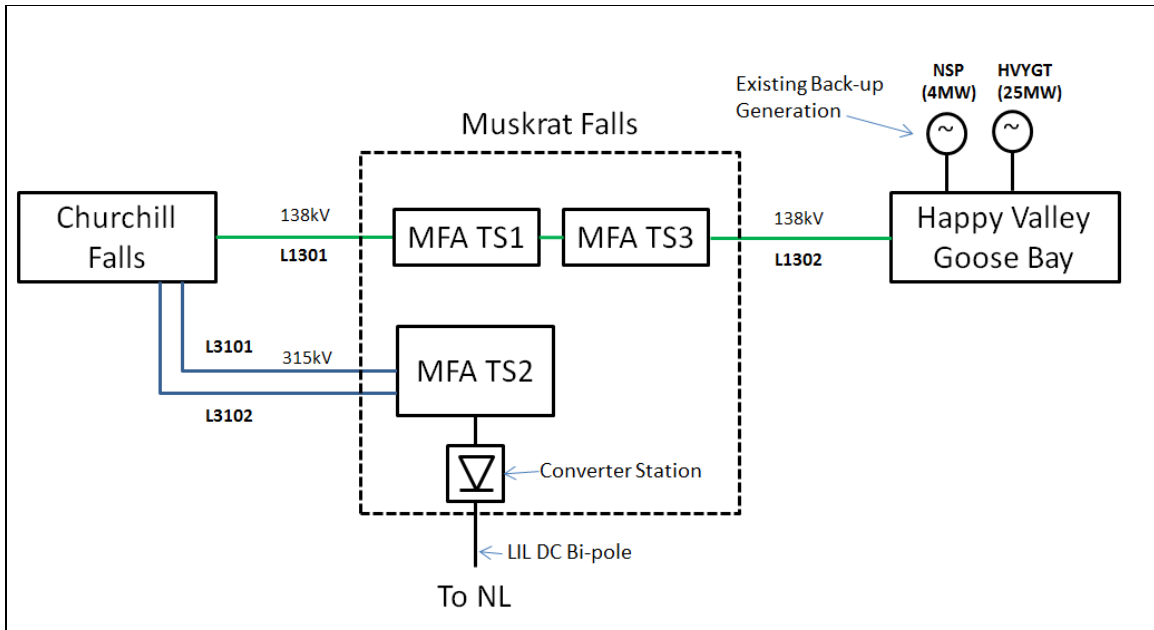

**Figure 3: Labrador East Interconnected System (Block Diagram)**

1 At Churchill Falls, transmission line L1301 is connected to a 230/138 kV, 75/100/125 MVA  
 2 autotransformer which is equipped with an on load tap changer to provide 138 kV system  
 3 voltage regulation. The configuration of the Churchill Falls Terminal Station includes a standby  
 4 42 MVA, 230/138 kV transformer. This system supplies Happy Valley-Goose Bay loads at the  
 5 Happy Valley Terminal Station (“HVYTS”) and also supplies a 70 kW pump station load at  
 6 Muskrat Falls Terminal Station 1 (“MFATS1”).

7

8 The L1301 transmission line was tapped and a new terminal station Muskrat Falls Terminal  
 9 Station 3 (“MFATS3”) was established to supply construction power for the Lower Churchill  
 10 Project. Due to an increase in load demand from both the Muskrat Falls Project and the Happy  
 11 Valley-Goose Bay area, 21.6 MVAR of capacitor banks were added to this tap station to improve  
 12 power transfer capability and to maintain acceptable voltages.

13

14 As a requirement for the Lower Churchill Project, there were two, 250 km, 315 kV lines  
 15 constructed between Churchill Falls and Muskrat Falls. A 735/315 kV station was built in  
 16 Churchill Falls to interconnect these two, 315 kV lines. The Muskrat Falls generating station and

1 its associated 315 kV terminal station (“MFATS2”) and HVdc converter station (“MFACS”) are  
2 located on the south side of the Churchill River. The Labrador-Island Link (“LIL”) is a 1,100 km  
3 HVdc bipole link that originates at MFACS and connects to the Newfoundland grid at the  
4 Soldiers Pond Converter Station (“SOPCS”), operating at +/-350 kVdc with a capacity of 900  
5 MW.

6  
7 At the HVYTS, there are three, 138/25 kV transformers, all equipped with on-load tap changers  
8 that provide voltage regulation for the Happy Valley Distribution System. There are also 11.4  
9 MVAR of switched shunt capacitor banks and a 25 MW gas turbine (“HVGTT”), with  
10 synchronous condenser capabilities. The shunt capacitors and the synchronous condenser  
11 provide reactive power support to maintain acceptable voltages.

12  
13 At the North Side Diesel Plant (“NSP”), there is approximately 4 MW of diesel generation;  
14 however, due to the deteriorating condition of the plant, it is not reliable as a long term source  
15 of capacity.

## 17 **2.2 Labrador West**

18 As indicated in Figure 2, the electrical power system in Labrador West is supplied via two, 230  
19 kV transmission lines (L23 and L24) from Churchill Falls to the Wabush Terminal Station  
20 (“WTS”). Not to be confused with the Wabush Substation,<sup>6</sup> the WTS steps down the voltage  
21 from 230 kV to two, 46 kV buses (B15 and B13) separated by a normally open 46 kV bus tie  
22 circuit breaker. There are a total of eight power transformers in the WTS as summarized in  
23 Table 1. The WTS also contains two, -40/+60 MVAR Synchronous Condensers designated as SC1  
24 and SC2. A third synchronous condenser (SC3) (rated for -20/+60 MVAR) is also located at the  
25 WTS. This asset is owned by the Iron Ore Company of Canada (“IOC”) and is not yet  
26 commissioned. There are also two, 25.2 MVAR, 46 kV capacitor banks (C1 and C2), one  
27 connected to each 46 kV bus.

---

<sup>6</sup> Wabush Substation is a 46/25 kV station that provides service for Hydro Rural Customers.

**Table 1: Wabush Terminal Station – Power Transformers**

Transformer	Voltage Rating (kV)	Power Rating (MVA) <sup>7</sup>	46kV Bus
T1	230/46	35/47/58/65	B13
T2	230/46	35/47/58/65	B13
T3	230/46	35/47/58/65	B13
T4	230/46	35/47/58/65	B15
T5	230/46	35/47/58/65	B15
T6	230/46	35/47/58/65	B15
T7	230/46	50/66.7/83.3	B15
T8	230/46	50/66.7/83.3	B13

1 The 46 kV buses in the WTS supply power to the towns of Wabush and Labrador City, as well as  
 2 IOC. The 46 kV bus B15 once served Wabush Mines ("WM"), and its 46 kV feed provides an  
 3 interconnection for Tacora Ltd., the present operator of the Wabush Mines site.<sup>8</sup> The  
 4 residential and commercial customers in Labrador City are delivered power through 46 kV lines  
 5 L32 and L33 that connect to the Quartzite and Vanier 46/25 kV substations, respectively. In  
 6 addition there is a 46 kV tie line to Fermont, Québec.

7  
 8 The Wabush Substation delivers power to the town of Wabush and is supplied by a single 46 kV  
 9 line, L36, from the WTS. The Wabush Substation has a total of four step-down power  
 10 transformers which reduce the transmission line voltage from 46 to 12.5 kV, as listed in Table 2.

<sup>7</sup> For transmission planning purposes the summer, spring/fall and winter rating limits of all power transformers and autotransformers will be equal to the nameplate rating at 25 °C ambient as provided by the manufacturer, as per Section 6.1 of *NLSO Standard TP-S-001 - Transmission Facilities Rating Guide*.

<sup>8</sup> There is minimum flexibility to move 46 kV feeder loads from one 46 kV bus to the other.

**Table 2: Wabush Substation – Power Transformers**

Transformer	Status	Voltage Rating (kV)	Power Rating (MVA)
T3	In Service	46/25-12.5	5/6.6/8.3
T4	Spare	46/25-12.5	5/6.6/8.3
T5	Spare	46/12.5	3/4
T6	In Service	46/12.5-4.16	10/13.3/16.67

- 1 The Wabush Substation has a total installed capacity of 37.3 MVA and a firm transformation
- 2 capacity<sup>9</sup> of 20.6 MVA.<sup>10</sup> Refer to Figure 4 for a block diagram of the existing 46 kV distribution
- 3 system in Labrador West.

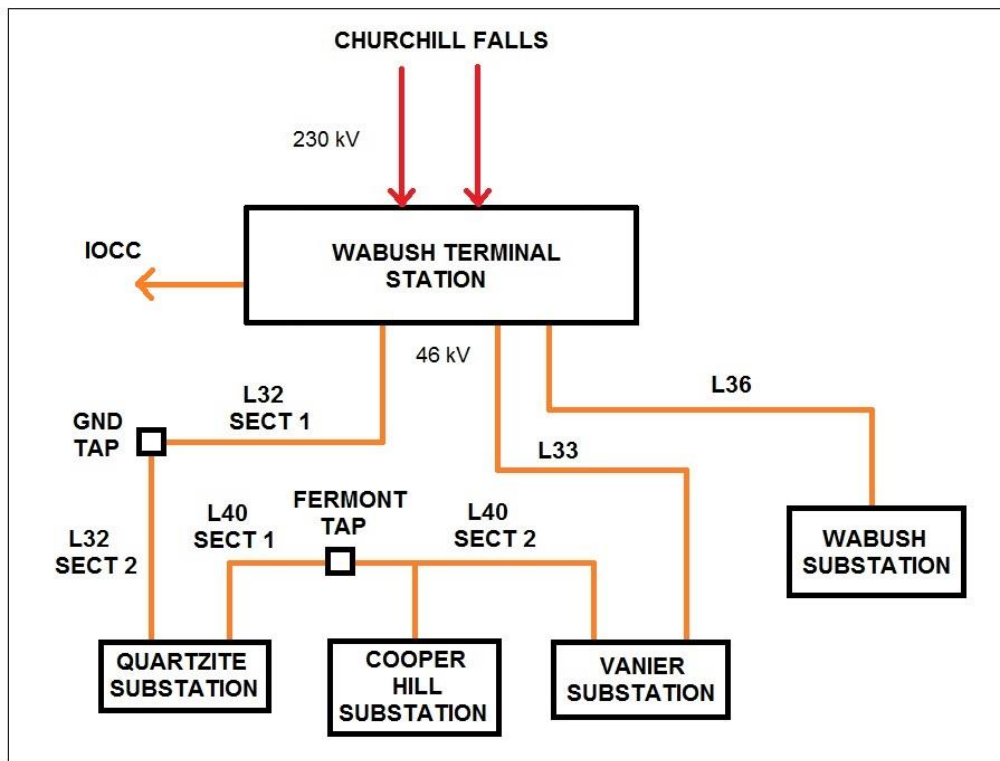

**Figure 4: Labrador West Interconnected System**

<sup>9</sup> The firm transformation capacity is the total station capacity less the transformer with the largest rating.

<sup>10</sup> Additional detail relating to the spare transformers is provided in Appendix C.

1 **2.3 Transmission Planning Criteria**

2 Hydro’s prescribed Transmission Planning Criteria<sup>11</sup> are applied within the Newfoundland and  
3 Labrador Interconnected System (“NLIS”). However, these criteria are only applied to the  
4 portion of the NLIS that is defined as the Primary Transmission System (“PTS”). The PTS includes  
5 the portions of the NLIS that permit the bulk flow of electricity across the transmission system.  
6 This consists of the 230 kV transmission system on the island of Newfoundland, the LIL, and the  
7 735 kV and 315 kV transmission systems in Labrador.

8  
9 Hydro has modified its approach to transmission planning for the Labrador Interconnected  
10 System to balance reliability with customer costs as a result of the small number of customers  
11 bearing system costs. Historically, Hydro has not applied rigid transmission planning criteria for  
12 the transmission systems in eastern and western Labrador. The Labrador East transmission  
13 system is classified as a Radial Transmission System and the Labrador West transmission system  
14 is classified as a Local Network. In contrast to the PTS, these systems distribute power to  
15 specific customers and are designed to meet the reliability requirements and balance customer  
16 cost impacts. If there was a strict application of transmission planning criteria on the LIS,  
17 significant expansion of the transmission system would be required.

18  
19 For example, at the HVYTS and at stations in Labrador West, criteria relating to power  
20 transformers are applied to ensure there is sufficient installed firm capacity to withstand the  
21 loss of the largest unit. This is due to the significant time required to replace a power  
22 transformer and there is no back-up transformation readily available in Labrador.

23  
24 However, n-1 criteria,<sup>12</sup> which are applied in a PTS, are not applied to high voltage terminal  
25 stations and transmission lines in eastern and western Labrador. This is due to the significant  
26 expansion costs that would be borne by a small number of customers. As a result, an outage to

---

<sup>11</sup> TP-S-007 - Transmission Planning Criteria, Hydro.

<sup>12</sup> The ability to withstand the loss of a system element without customer impact is referred to as n-1 criteria.

1 a transmission line or station element (such as a bus) has the potential to result in a customer  
2 impact.

3

4 This Expansion Study involves a review of multiple expansion alternatives for both systems.  
5 Transmission Planning Criteria are not strictly applied for these alternatives. Rather, the intent  
6 of the expansion plans is to effectively supply forecasted customer peaks with a level of  
7 reliability that is, at a minimum, comparable to that of the existing transmission system while  
8 ensuring acceptable rate impacts.

9

### 10 **3 Forecasts**

#### 11 **3.1 Load Forecasts**

12 Hydro's 10-year LIS Load Forecast is included in Table 3, along with a 15-year extension which  
13 assumes Hydro's rural load is increasing at the five-year average. This P90 peak load forecast,  
14 released in July 2018, is used as the basis for the analysis in this report.

**Table 3: Baseline Coincident Peak Forecast (Labrador Interconnected System) (MW)**

Year	Labrador East	Labrador West	Unrestricted Baseline Peak <sup>13</sup>
	Base Coincident Peak		
2018	81.7		342.4
2019	83.3		358.4
2020	83.5		369.0
2021	83.8		377.1
2022	84.0		377.3
2023	84.3		377.6
2024	84.9		377.9
2025	85.4		378.2
2026	85.9		378.5
2027	86.4		378.8
2028	86.9		379.1
2029	87.5		379.4
2030	88.0		379.6
2031	88.5		379.9
2032	89.0		380.2
2033	89.6		380.5
2034	90.1		380.7
2035	90.6		381.0
2036	91.1		381.2
2037	91.7		381.4
2038	92.2		381.7
2039	92.7		381.9
2040	93.3		382.2
2041	93.8		382.4
2042	94.3		382.7
2043	94.8		382.9

1 **3.1.1 Labrador East**

- 2 For eastern Labrador, the load growth experience of the past eight years has included a period  
 3 of robust growth followed by a period of low growth in the past three years. The recent growth

<sup>13</sup> The unrestricted baseline peak load forecast includes loads for Hydro Rural, IOC, and Tacora. Under existing system conditions, power on order for IOC and Tacora must be limited such that the total coincident peak for the system does not exceed 350 MW. The restricted baseline peak load forecast is therefore limited to 350 MW.

1 in both residential customers and general service sales has been largely influenced by the  
2 Muskrat Falls Project construction.

3  
4 Looking forward, the near-term load growth on the system is expected to be primarily driven by  
5 general service sales growth associated with recently approved data centre developments.  
6 Energy sales to the Department of National Defence’s (“DND”) large general service account  
7 amounts to roughly 30 percent of total general service sales on this system and is expected to  
8 remain stable. Potential exists for load increase associated with DND should it convert its  
9 central heating plant fuel from oil to electricity. For the longer term, forecasted load growth  
10 reflects a return to typical residential customer growth and modest expansion of the area’s  
11 general service loads.

12

### 13 **3.1.2 Labrador West**

14 Retail load growth experienced in Labrador West for the past decade was positively influenced  
15 by the strength of the global iron ore industry during the mid-2000s through to 2012. Increasing  
16 electricity requirements materialized during this time period for both residential and general  
17 service sectors but stagnated for both sectors post 2014, coinciding with the reduction of load  
18 related to the iron ore mine at Wabush. Beginning in 2017, increased electricity requirements  
19 materialized in the general service sector associated with recently approved data centre  
20 developments.

21

22 Looking forward, the near-term load growth within the region is primarily driven by general  
23 service sales growth associated with recently approved data centre developments. Based on  
24 expressed interest in data centre developments, the potential for increased general service  
25 electricity sales within this region is considered significant. Residential customer growth and  
26 associated electricity sales is expected to be largely dependent on the re-establishment of  
27 mining operations at Wabush or new mining developments. For the longer term, forecasted  
28 load growth reflects a return to typical residential customer growth and modest expansion of  
29 the community’s general service loads.



1 For the purposes of this investigation, the baseline load forecast includes load increases  
 2 associated with Tacora operations at the Wabush Mines site. Hydro currently receives monthly  
 3 power on order requests to accommodate the ramp up of this operation. The transmission  
 4 system expansion plans developed in this report are designed to accommodate the full  
 5 operation of this facility.<sup>14</sup>

### 7 3.2 Fuel Price Forecast

8 The HVYGT generator consumes diesel fuel and is located in the Happy Valley Terminal Station.  
 9 The HVYGT extended fuel price forecast considered for this Expansion Study is shown in Table  
 10 4.

**Table 4: Fuel Price Forecast (Happy Valley-Goose Bay)<sup>15</sup>**

Year	\$/L
2018	1.26
2019	1.35
2020	1.50
2021	1.41
2022	1.36
2023	1.35
2024	1.37
2025	1.38
2026	1.41
2027	1.44
2028	1.46
2029	1.48
2030	1.51
2031	1.54
2032	1.57
2033	1.59
2034	1.62
2035	1.65
2036	1.68

<sup>14</sup> In the event Tacora operations do not materialize, the baseline load forecast will not exceed the 350 MW capacity of the existing transmission system. The resulting impacts of such a change in forecast are addressed in sections of this report relating to transmission system expansion plans.

<sup>15</sup> Price forecast reflects the landed cost of No. 2 fuel specifications used by Hydro for HVYGT and NSP diesels. Carbon levies reflect provincial carbon plan. Carbon levies begin in 2019 at \$20 per tonne. Diesel fuel price forecast is consistent with Nalcor Corporate Assumptions for August 2018.

Year	\$/L
2037	1.71
2038	1.74
2039	1.77
2040	1.80
2041	1.84
2042	1.87
2043	1.91

## 1 **4 System Deficiencies**

2 The main focus of this report is to assess the system deficiencies driven by load growth on the  
 3 LIS and develop least-cost, reliable transmission system expansion plans for ranges of loading  
 4 conditions. The following system deficiencies were identified during this Expansion Study:<sup>16</sup>

- 5 • Transmission Line Transfer Limits to Labrador East;
- 6 • Transmission Line Transfer Limits to Labrador West;
- 7 • Transformation Capacity – Wabush Substation; and
- 8 • Transmission Line Thermal Limits – 46 kV System.

9  
 10 The following sections provide further detail on each of these items.

11

### 12 **4.1 Transmission Line Transfer Limits to Labrador East and West**

#### 13 **4.1.1 Labrador East**

14 Analysis of the existing 138 kV transmission system configuration serving Labrador East  
 15 indicates that the system is capable of delivering 77 MW to the 25 kV bus in the HVYTS. For load  
 16 levels beyond 77 MW, system voltages will deteriorate ultimately resulting in system voltage  
 17 collapse and customer outages. The projected peak load for the area and expected capacity  
 18 deficit from 2018 to 2043 is shown in Table 5. To support load levels beyond 77 MW in the  
 19 Happy Valley-Goose Bay area, the capacity of the transmission system supplying the area must

---

<sup>16</sup> As noted in Section 2.2 the baseline forecast for western Labrador does not include new major customer interconnections and can be supplied by the existing transmission system. There are, therefore, no deficiencies for this baseline scenario. Expansion requirements associated with incremental loads are presented in Section 7.

- 1 be increased or L1301 must be offloaded. An outline of the technically feasible alternatives to
- 2 address this concern is provided in Section 5.1.

**Table 5: Transfer Capacity Deficits – Labrador East (MW)**

Year	Forecasted Load	Capacity Deficit
2018	81.7	4.7
2019	83.3	6.3
2020	83.5	6.5
2021	83.8	6.8
2022	84.0	7.0
2023	84.3	7.3
2024	84.9	7.9
2025	85.4	8.4
2026	85.9	8.9
2027	86.4	9.4
2028	86.9	9.9
2029	87.5	10.5
2030	88.0	11.0
2031	88.5	11.5
2032	89.0	12.0
2033	89.6	12.6
2034	90.1	13.1
2035	90.6	13.6
2036	91.1	14.1
2037	91.7	14.7
2038	92.2	15.2
2039	92.7	15.7
2040	93.3	16.3
2041	93.8	16.8
2042	94.3	17.3
2043	94.8	17.8

### 3 **4.1.2 Labrador West**

- 4 The transfer capability of the existing Labrador West Transmission System is 350 MW under
- 5 normal operating conditions with all equipment in service. This is due to voltage limitations at
- 6 the WTS. As outlined in Section 3, the P90 baseline load forecast will exceed 350 MW in 2019

1 and will reach 383 MW by the year 2043.<sup>17</sup> Supply to industrial customers must therefore be  
2 restricted over peak until some action is implemented. The following list summarizes transfer  
3 limits under specific contingency events:

- 4 • winter limitation with L23 or L24 out of service: 252.0 MW due to voltage limitations at  
5 WTS;
- 6 • summer limitation with all equipment in service: 324.0 MW due to thermal limitations  
7 on L23 and L24;
- 8 • summer limitation with L23 or L24 out of service: 164.0 MW due to thermal limitations  
9 on L23 and L24;
- 10 • loss of T7 power transformer: maximum transfer limit of 345 MW due to transformer  
11 overloading;
- 12 • loss of T8 power transformer: no transformer overloads, however, transfer capability is  
13 reduced to 345.2 MW due to voltage limitations;
- 14 • loss of C1: maximum transfer with C1 out is 329 MW due to voltage limitations;
- 15 • loss of C2: maximum transfer with C2 out is 316 MW due to voltage limitations;
- 16 • loss of SC1: With the bus tie open, the maximum power transfer limit is 298 MW. With  
17 the bus tie closed, the maximum transfer is 306 MW due to voltage limitations; and
- 18 • loss of SC2: With the bus tie open, the maximum transfer limit is 290 MW due to voltage  
19 issues. With the bus tie closed the maximum transfer capability is 305 MW.

20  
21 As summarized above, the loss of transmission system elements may result in load interruption.  
22 The Labrador West transmission system has a firm transmission capability of 252 MW in the  
23 winter and 164 MW in the summer. To increase the firm transmission capability of the system  
24 to meet peak loading conditions, a major system expansion is required. Such an expansion  
25 would have a significant rate impact. Under the present operating conditions, customer  
26 interruptions are required.

---

<sup>17</sup> As discussed in Section 3.1.2, the baseline load forecast includes load increases associated with Tacora operations at the Wabush Mines site. In the event this does not materialize, the load forecast will not exceed 350 MW and additions to increase system capacity will therefore not be required.

1 The expansion plans presented in this report are designed to ensure that the full baseline load  
2 forecast of 383 MW can be met with all equipment in service without customer interruption.  
3 These expansion scenarios do not allow for firm delivery to peak industrial customer loads with  
4 equipment out of service. Rather, interruptions to industrial customers may be required in the  
5 event of outages to system elements. This is in accordance with existing operating practice.

6  
7 Section 7 includes a review of forecast sensitivities to reflect the interconnection of incremental  
8 large customer loads and the impact on capacity within the Labrador West Interconnected  
9 System.

10

#### 11 **4.2 Transformation Capacity – Wabush Substation**

12 For stations where suitable back-up transformation is not available, redundancy must be  
13 applied. In the event of a failure to the largest transformer at the Wabush Substation during  
14 peak conditions, the remaining transformers must be capable of supporting peak demand.  
15 However, according to the load forecasts prepared by Hydro in July of 2018, electrical demand  
16 in Wabush is expected to exceed the firm transformation capacity in the substation. The  
17 expected peak demand in Wabush for the 2018-2019 winter season is 23.3 MW (or 23.8 MVA),  
18 which exceeds the firm transformation capacity (20.6 MVA) by approximately 15 percent. Table  
19 6 provides the expected transformation capacity deficits at the Wabush Substation from 2018  
20 to 2043.

21

22 Appendix C includes further explanation of the transformation capacity deficit at the Wabush  
23 Substation. An outline of the alternatives to address this deficit is summarized in Section 5.3.

**Table 6: Transformation Capacity – Wabush Substation (2018 to 2043)**

Year	Forecasted Load (MW)	Forecasted Load (MVA)	Capacity Deficit (MVA)
2018	23.3	23.7	3.1
2019	23.3	23.8	3.2
2020	23.3	23.8	3.2
2021	23.5	23.9	3.3
2022	23.6	24.1	3.5
2023	23.7	24.2	3.6
2024	23.8	24.3	3.7
2025	23.9	24.4	3.8
2026	24.0	24.4	3.8
2027	24.1	24.5	3.9
2028	24.1	24.6	4.0
2029	24.2	24.7	4.1
2030	24.3	24.8	4.2
2031	24.4	24.9	4.3
2032	24.5	25.0	4.4
2033	24.5	25.0	4.4
2034	24.6	25.1	4.5
2035	24.7	25.2	4.6
2036	24.8	25.3	4.7
2037	24.9	25.4	4.8
2038	25.0	25.5	4.9
2039	25.0	25.5	4.9
2040	25.1	25.6	5.0
2041	25.2	25.7	5.1
2042	25.3	25.8	5.2
2043	25.4	25.9	5.3

**1 4.3 Transmission Line Thermal Units – 46 kV System**

2 A load flow analysis was performed to assess the network of 46 kV transmission lines that  
 3 supply Hydro Rural customers in Labrador City and Wabush. This analysis, which is presented in  
 4 Appendix D, indicates that line upgrades to the 46 kV transmission system are required to avoid  
 5 customer interruptions due to line outages.

6  
 7 This analysis considers a range of peak loading conditions, including a baseline peak forecast  
 8 and a sensitivity forecast that includes incremental data centre loads. The analysis was  
 9 performed on the basis of reliable supply to Hydro Rural customers without 46 kV transmission

1 line overloads for conditions with all lines in service or with one 46 kV transmission line out of  
2 service.<sup>18</sup> Transmission line ratings were calculated in accordance with *NLSO Standard TP-S-001*  
3 - *Transmission Facilities Rating Guide*.

4  
5 The results of the analysis indicate that transmission lines overloads exist in peak load  
6 conditions. To prevent the thermal overloading in the baseline forecast condition, the re-  
7 conductoring of 46 kV transmission lines L32, L33, and L40 is required. The capital cost  
8 associated with this work is estimated to be approximately \$1.4 million. This work will ensure  
9 sufficient capacity to meet peak load conditions for the 25-year study period.

10  
11 To prevent overload conditions in the sensitivity forecast condition, the reconductoring noted  
12 above, as well as that of L36, is required. The capital cost associated with this work is estimated  
13 to be approximately \$1.8 million. This work will ensure sufficient capacity to meet peak load  
14 conditions for the 25- year study period.

15  
16 Analysis indicates that transmission line overload conditions currently exist for an outage to L32  
17 or L33 during peak load conditions and that a Hydro rural customer curtailment in excess of 20  
18 MW will be required in worst case conditions. It is therefore recommended that a proposal for  
19 the reconductoring of L32, L33 and L40 be included as part of Hydro's 2020 Capital Budget  
20 Application. If required for future incremental load requests, the reconductoring of L36 will be  
21 assessed as part of associated impact studies.

22

## 23 **5 Description of Alternatives**

24 Cost benefit analyses were conducted as part of this Expansion Study to determine the least-  
25 cost, reliable solutions for addressing the deficiencies presented in Section 4.<sup>19</sup> This section will  
26 provide a brief description of the scope for each alternative considered.

---

<sup>18</sup> The reconductoring of transmission lines in the 46 kV network will allow for firm supply to Hydro Rural customers in the event of a 46 kV line outage for all but one contingency. The exception is L36, which is the radial line to the Wabush Substation. Appendix D includes a description of costs associated with an option to build a second line to Wabush substation and is further discussed in Section 10.

1 **5.1 Long-Term Supply to Labrador East**

2 The following alternatives were assessed during this Expansion Study to address the issue of the  
3 138 kV transmission transfer limits to Labrador East. Each proposed alternative will support the  
4 baseline forecasted demand of Happy Valley-Goose Bay beyond the year 2043.

- 5 • Alternative 1: Offload L1301/L1302; and
- 6 • Alternative 2: Muskrat Falls to Happy Valley Interconnection.

7

8 **5.1.1 Alternative 1: Offload L1301/L1302**

9 The proposed plan for Alternative 1 is to offload L1301/L1302 under peak conditions through  
10 the interruption of customer load and the operation of back-up generation on the Happy  
11 Valley–Goose Bay system. Hydro has recently received approval for the interruption of one  
12 large customer interconnected to the Labrador East system. This proposed alternative will  
13 support a peak demand of approximately 96 MW,<sup>20</sup> assuming the indefinite extension of the  
14 existing interruptible load agreement and a HVYGT winter capacity of 25 MW.

15

16 For this alternative and as long as the power is delivered over L1301/L1302, the HVYGT must be  
17 capable of reliably switching from synchronous condenser mode to generation mode whenever  
18 the Labrador East load is expected to exceed 82.5 MW.<sup>21</sup> Although additional capacity is not  
19 required until the load reaches 82.5 MW, the switch to generation mode must occur before the  
20 load in Labrador East reaches 65 MW. If the HVYGT were to trip during the mode conversion  
21 process at a load greater than 65 MW, there is a significant risk of system voltage collapse.  
22 Consequently, Hydro would be forced to extend the operation of the HVYGT during peak  
23 conditions (i.e., above 65 MW) to ensure system reliability, which translates into an increased  
24 amount of additional fuel being consumed by the HVYGT.

---

<sup>19</sup> As noted in Section 2.2, the baseline forecast for western Labrador does not include new major customer interconnections and can be supplied by the existing transmission system. There are, therefore, no deficiencies for this baseline scenario. Expansion requirements associated with incremental loads are presented in Section 7.

<sup>20</sup> 77 MW – 5.5 MW (Interruptible Load) + 25 MW (HVYGT) = 96.5 MW.

<sup>21</sup> (The transfer capacity of L1301) + (The expected amount of interruptible load) = 77 MW + 5.5 MW = 82.5 MW.



1 This alternative will also require the addition of more transformation at the Churchill Falls and  
2 Happy Valley terminal stations, since these stations do not have suitable back-up  
3 transformation. Transformer T32 in Churchill Falls will be replaced with a 125 MVA transformer  
4 and T2 or T4 in Happy Valley-Goose Bay will be replaced with a 50 MVA transformer.

5  
6 The capital budget estimate for this project is approximately \$8.2 million. The majority of the  
7 lifecycle costs associated with this alternative are operational costs for fuel and controlled  
8 customer interruption.

9

### 10 **5.1.2 Alternative 2: Muskrat Falls to Happy Valley Interconnection**

11 This project proposes tapping transmission line L1302 at the Muskrat Falls 138/25 kV Tap  
12 Station (“MFATS3”) and the addition of a 6 km segment of 138 kV wood pole transmission line  
13 constructed to the Muskrat Falls 315 kV Terminal Station (“MFATS2”). The Muskrat Falls 315 kV  
14 Terminal Station is being constructed to provide Hydro with two, 138 kV supply connections via  
15 315 kV/138 kV, 125 MVA transformers. At these connections, Hydro will install a partial ring bus  
16 to interconnect the two, 138 kV supplies from Muskrat Falls and to terminate the new 6 km  
17 segment to L1302. In the event of a failure resulting in isolation from the 315 kV system, L1301  
18 will serve as a back-up feed to the Labrador East system.

19

20 As this project will increase the maximum fault level at the HVYTS, five reclosers and one circuit  
21 breaker will need to be replaced with six new circuit breakers. A new 138/25 kV, 50 MVA  
22 transformer will be required to allow for the projected load increase. To house the new  
23 protection and control infrastructure that will be required, a new control building will be  
24 constructed in the HVYTS.

25

26 With the completion of an interconnection, the system capacity increases to 104 MW, based on  
27 the transformation capacity at the HVYTS following the addition of the new 50 MVA  
28 transformer. An additional 25 MW of capacity can be provided if the HVYGT is placed into

1 service.<sup>22</sup> The proposed interconnection of Muskrat Falls to Happy Valley will also considerably  
2 improve system reliability as presented in the 2018 Capital Budget Application and Appendix E,  
3 “Reliability Assessment of the 138kV lines Supplying Labrador East”.

4  
5 Since the power delivered to the Labrador East System will flow through the two, 315 kV lines  
6 under this scenario, as opposed to a single 138 kV transmission line, there will be a significant  
7 reduction in power losses. There will be an annual reduction of at least 900 MWh per year and  
8 approximately 20 MW of demand over peak. This effectively increases power availability in  
9 Labrador over peak. Unused power in Labrador may also be utilized on the island or exported to  
10 external markets.

11  
12 The capital budget estimate for this project is approximately \$20.0 million. The majority of this  
13 cost is associated with required upgrades to the HVYTS.

14  
15 Figure 5 provides a simplified diagram of the proposed Muskrat Falls to Happy Valley  
16 Interconnection.

---

<sup>22</sup> With a Muskrat Falls to Happy Valley Interconnection and given the most recent load forecast, there is no concern of voltage collapse in the event that the HVYGT trips during mode conversion.

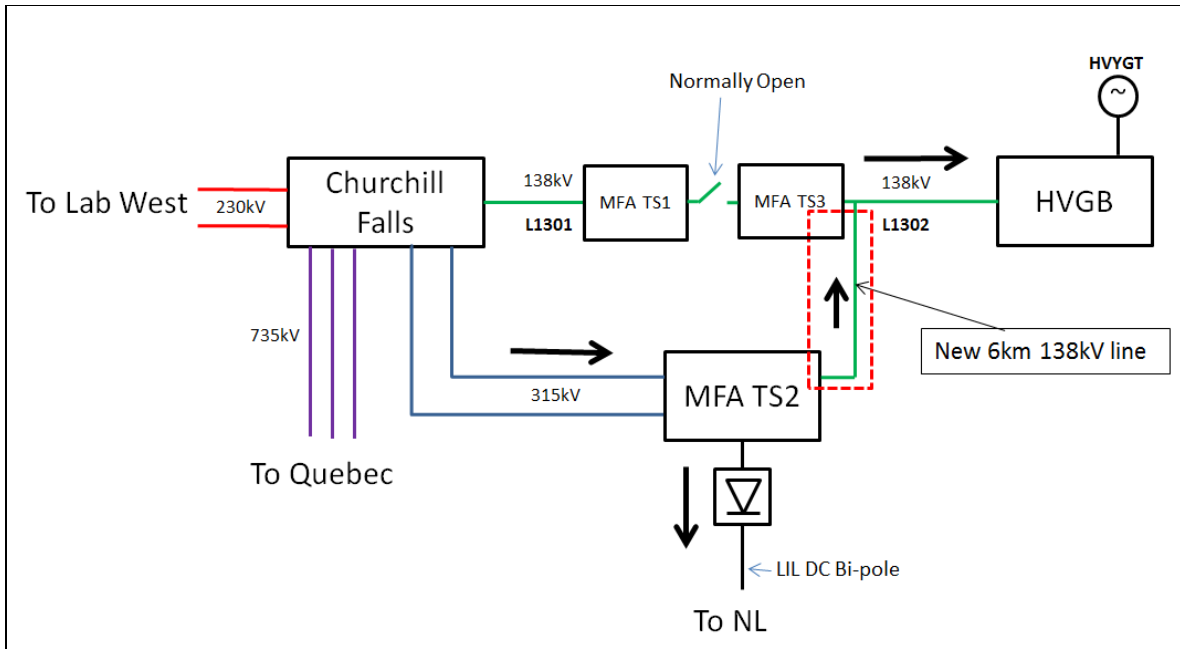

Figure 5: Muskrat Falls to Happy Valley Interconnection

1 **5.2 Long-Term Supply to Labrador West**

2 **5.2.1 Transmission System Capacity Upgrades**

3 The analysis provided in Appendix B includes a description of the system additions that would  
 4 be required to increase transmission system capacity in western Labrador to meet the peak  
 5 baseline forecast of 383 MW.

6

7 The upgrades include the commissioning of the third synchronous condenser at Wabush  
 8 Terminal Station,<sup>23</sup> the installation of an additional 23 MVAR of shunt compensation, and  
 9 replacement of transformers T4 and T5 with 125 MVA units. These upgrades will increase  
 10 system capacity to meet the baseline peak load forecast of 383 MW.

<sup>23</sup> As this asset belongs to IOC, the establishment of a commercial arrangement will be required for this unit to be placed in service. In the near term, Hydro will explore opportunities to accelerate the commissioning of Synchronous Condenser #3 to avoid industrial customer load curtailment in 2019.

1 The estimated capital cost of this project is approximated to be \$15.0 million.<sup>24</sup>

2

### 3 **5.3 Wabush Substation – Capacity Upgrade**

4 The following alternatives were considered to address the issue of transformation capacity at  
5 the Wabush Substation. Each proposed alternative will support the baseline forecasted demand  
6 of Wabush beyond the year 2043:

- 7 • Alternative 1: Substation Upgrade - Two Transformer Option;
- 8 • Alternative 2: Substation Upgrade – Three Transformer Option;
- 9 • Alternative 3: Addition of 12.5kV Bus at the Wabush Terminal Station; and
- 10 • Alternative 4: Addition of 12.5kV Bus at the Flora Lake Terminal Station.

11

12 Details relating to each alternative are presented in the transmission planning analysis found in  
13 Appendix C.

14

#### 15 **5.3.1 Alternative 1: Substation Upgrade – Two Transformers**

16 In this scenario, the four existing 46/12.5 kV transformers will be replaced with two new 33.25  
17 MVA units in parallel, resulting in the station having installed redundancy as each power  
18 transformer will be able to support the entire town of Wabush load. The two new power  
19 transformers will be equipped with On Load Tap Changers (“OLTC”), which will regulate the  
20 voltage on the 12.5 kV buses and eliminate any low voltage conditions on the distribution  
21 system for the foreseeable future. A 12.5 kV breaker will be installed on the low side of each  
22 power transformer, while motorized disconnects will be installed on the high side. This  
23 arrangement will allow for the quick isolation of a fault with minimal disruption to the  
24 unaffected areas of the system. The 46 kV oil-filled circuit breaker will be replaced, as it is  
25 reaching the end of its useful life. To provide additional reliability, a bus tie circuit breaker will  
26 be added between 12.5 kV buses B5 and B3. All the existing transformers will no longer be

---

<sup>24</sup> As discussed in Section 3.1.2, the baseline load forecast includes load increases associated with Tacora operations at the Wabush Mines site. In the event this does not materialize, the load forecast would not exceed 350 MW and additions to increase system capacity would therefore not be required.

1 utilized in the Wabush Substation and will be stored as spares. A new control building will be  
2 purchased and installed on the south side of the station. This building will house all the  
3 protection, control and communication equipment.

4

5 The estimated capital cost of this project is approximated to be \$13.4 million.

6

### 7 **5.3.2 Alternative 2: Substation Upgrade – Three Transformers**

8 In this scenario, two of the existing 46/12.5 kV transformers, T4 and T6, will be utilized, while  
9 the other two, T3 and T5, will be removed and stored as spares. An additional 25 MVA unit, T7,  
10 complete with OLTC for voltage regulation will be installed. This new transformer will be  
11 capable of supporting the entire town of Wabush load until 2038-2039, at which time  
12 transformer T4 will be upgraded with a 16.7 MVA unit complete with OLTC. Transformer T4 will  
13 be used as a spare, and will be connected in the event of a transformer T7 failure. In this  
14 configuration, transformer T7 must not be paralleled with T4 or T6 as it will increase the fault  
15 levels beyond the interrupting ratings of the reclosers. A 12.5 kV breaker will be installed on the  
16 low side of each power transformer, while motorized disconnects would be installed on the  
17 high side. This arrangement will allow for the quick isolation of a fault with minimal disruption  
18 to the unaffected areas of the system. Voltage regulators will be installed on both L11 and L13,  
19 as these are the most heavily loaded feeders and have experienced low voltages at the end of  
20 their lines. In the event that transformer T7 is out of service, the voltage regulators will provide  
21 voltage regulation on those lines. The 46 kV oil-filled circuit breaker will be replaced, as it is  
22 reaching the end of its useful life. To provide additional reliability, a bus tie circuit breaker will  
23 be added between 12.5 kV buses B5 and B3. A new control building will be purchased and  
24 installed on the south side of the station. This building will house all the protection, control and  
25 communication equipment.

26

27 The estimated capital cost of this project is approximated to be \$8.4 million.

1 **5.3.3 Alternative 3: Addition of 12.5kV Bus at the Wabush Terminal Station**

2 In this scenario, WTS will be expanded by the construction of a 12.5 kV bus. A new 12.5 kV  
3 distribution line will be built to supply the load at Wabush Industrial Park and offload Wabush  
4 Substation. Wabush Substation feeders L11 and L13 will be tied together and connected to WTS  
5 via the new 12.5 kV line.

6  
7 The estimated capital cost of this project is approximated to be \$12.3 million.

8  
9 **5.3.4 Alternative 4: Addition of 12.5kV Bus at the Flora Lake Terminal Station**

10 In this scenario, construction of the Flora Lake Terminal Station will include a 12.5 kV bus. Two  
11 new 12.5 kV distribution lines will be built to supply the load at Wabush Industrial Park (thus  
12 offloading Wabush Substation by approximately 30 percent). Wabush Substation feeders L11  
13 and L13 will each be tied to new 12.5 kV lines from Flora Lake.

14  
15 It is noted that the Flora Lake Terminal Station is a potential station that can be built in  
16 Labrador West if there is significant load growth driving the need to upgrade the 230 kV  
17 system. The Flora Lake Terminal Station is described in more detail in Appendix B.

18  
19 The estimated capital cost of this project is approximated to be \$13.0 million.

20  
21 **6 Economic Analysis of Proposed Alternatives**

22 The economic analysis compares the cumulative present worth of each option to determine the  
23 least-cost option over a study period of 25 years.<sup>25</sup> The analysis considers the baseline load  
24 forecast and projected fuel prices as described in Section 3 and was conducted based on the  
25 following assumptions:

- 26
- P90 Baseline Forecast as per Section 3.1;
  - Fuel Price Forecast as per Section 3.2;
- 27

---

<sup>25</sup> The discount rate used in the Expansion Study is 5.9 percent which reflects Hydro's current long-term weighted average cost of capital.

- 1 • Marginal Cost of Energy: 3.5 cents per kWh;<sup>26</sup>
- 2 • Inflation and escalation rates as per the Conference Board of Canada;
- 3 • North Side Diesel Plant to be decommissioned by 2019;
- 4 • 5.5 MW of interruptible load in Happy Valley-Goose Bay;
- 5 • Cost of Interruptible Load: \$10/kW per month;
- 6 • O&M costs for L1301/L1302 were developed based on analysis performed in Appendix
- 7 E.

8

## 9 6.1 Results

### 10 6.1.1 Long-Term Supply to Labrador East

11 The results of the economic analysis to address the long-term supply for Labrador East are  
 12 summarized in Table 7.

**Table 7: Long-Term Supply of Happy Valley Cost Benefit Analysis Results**

**Alternative Comparison Cumulative Net Present Value (“CPV”) to the Year 2018 (\$ million)**

Alternatives	CPV	CPV Difference between Alternatives and the Least-Cost Alternative
Alternative 2: MF <sup>27</sup> to HVY <sup>28</sup> Interconnection	21.5	0
Alternative 1: Offload L1301/L1302	52.4	30.9

13 Alternative 2 is the least-cost option over Alternative 1 by a CPV difference of \$30.9 million. The  
 14 main drivers for this CPV difference include:

- 15 • Additional fuel cost associated with the increased operation of the HVYGT for
- 16 Alternative 1;

<sup>26</sup> Nalcor exports surplus energy to the North American grid at a historical profit margin of approximately 3.5 cents per kWh.

<sup>27</sup> Muskrat Falls (“MF”).

<sup>28</sup> Happy Valley (“HVY”).

- 1 • Reduced power losses associated with Alternative 2;
- 2 • Additional costs associated with Interruptible Service Options for Alternative 1; and
- 3 • Higher O&M costs associated with transmission lines L1301/L1302 for Alternative 1.

4

5 Based on the results outlined in Table 7, Hydro recommends the construction of the Muskrat  
6 Falls to Happy Valley Interconnection as the least-cost alternative to reliably meet the capacity  
7 requirements for customers. As summarized in Hydro’s 2018 Capital Budget Application, this  
8 alternative also provides a significant reliability improvement.

9

### 10 **6.1.2 Labrador West Transmission System Capacity**

11 As presented in Section 5.2.1, additions at the WTS are required to increase the capacity of the  
12 transmission system to meet the peak baseline load forecast of 383 MW without interruption  
13 to industrial customers.

14

15 As presented in Appendix B, an analysis was performed to compare the cumulative net present  
16 value of this expansion with the costs that would be incurred if industrial customers were  
17 compensated for load interruption. Such an approach is not acceptable as the basis of the  
18 analysis is to ensure adequate supply without customer curtailment with all equipment in  
19 service. However, analysis was performed to assess the cost of load curtailment for the  
20 purposes of comparison. For this scenario, it is assumed that a curtailment agreement is  
21 negotiated with industrial customers at a rate of \$10/kW per month such that any load in  
22 excess of 350 MW will be curtailed.<sup>29</sup>

23

24 The results of this analysis are presented in Table 8. As indicated, the cumulative net present  
25 value of the load interruption alternative is within \$1.6 million of the cost of the terminal  
26 station upgrades. The analysis indicates that if curtailable rates were increased to \$13/kW per  
27 month, the cost of interruption will exceed the cost of the terminal station upgrades.

---

<sup>29</sup> This is the value currently used for customer interruption in eastern Labrador.



**Table 8: Labrador West Transmission System Capacity Upgrade  
Cost Benefit Analysis Results**

**Alternative Comparison Cumulative Net Present Value to the Year 2018 (\$ million)**

Alternatives	CPV	CPV Difference between Alternatives and the Least-Cost Alternative
Alternative 1: Load Curtailment	11.6	0
Alternative 2: WTS Upgrades	13.2	+1.6

**1 6.1.3 Wabush Substation – Capacity Upgrade**

- 2 The results of the economic analysis to address the transformation capacity deficit at the  
3 Wabush Substation are summarized in Table 9.

**Table 9: Wabush Substation Capacity Upgrade Cost Benefit Analysis Results**

**Alternative Comparison Cumulative Net Present Value to the Year 2018 (\$ million)**

Alternatives	CPV	CPV Difference between Alternatives and the Least-Cost Alternative
Alternative 2: Substation Upgrade – Three Transformer Option	6.1	0
Alternative 3: Addition of 12.5kV Bus at WTS	9.9	+3.8
Alternative 1: Substation Upgrade – Two Transformer Option	10.4	+4.3
Alternative 4: Addition of 12.5kV Bus at Flora Lake Terminal Station	10.4	+4.3

- 4 Alternative 2 is the least-cost option over Alternative 3 by a CPV difference of \$3.8 million.  
5 The main driver for this CPV difference is the lower up-front capital cost associated with  
6 Alternative 2. Based on the results outlined in Table 9, Hydro recommends upgrading the  
7 Wabush Substation as per the three transformer configuration outlined in Section 5.3.2 as the  
8 least-cost option for supply to customers.

## 7 Considerations for Additional Load Growth

Given the current economic environment in Labrador with low electricity rates and the potential for increases in iron ore prices, there is a high likelihood of load growth in Labrador East and West above baseline forecasts. Analyses were performed in consideration of the potential of forecast sensitivities associated with the interconnection of major customer loads.

### 7.1 Labrador East

A 138 kV interconnection between Muskrat Falls and Happy Valley-Goose Bay will increase the system capacity from 77 MW to 104 MW (excluding back-up generation). The extended baseline forecast outlined in Section 3.1 does not exceed 104 MW, therefore, additional capacity is not required until at least the year 2043 under current assumptions. As a reference, the total Happy Valley-Goose Bay demand is expected to reach 94.8 MW by the year 2043, according to the baseline forecast. However, the interconnection of major customer loads such as continued data centre growth or the conversion of DND heating plants to electric boilers will advance the need for capacity upgrades on the Labrador East system. The analysis accounting for unforeseen load growth in Labrador East is provided in Appendix A. Table 10 provides an overview of the proposed future plans in Labrador East given a sudden increase in demand.

**Table 10: Labrador East – Proposed Future Phases**

Phase	Load Trigger (MW) <sup>30</sup>	Project Description	Cost Estimate (\$ million) <sup>31</sup>
1	>77	MF to HVY Interconnection	20
2	>104	Transformation Upgrade at HVYTS <sup>32</sup>	5
3	>125	Transformation Upgrade at HVYTS and MFATS2 <sup>33</sup>	15
4	>162	Construction of Second Line from MF to HVY	50

<sup>30</sup> Specific limits will depend on the technical requirements driven by future customer requests.

<sup>31</sup> High level cost estimates (Class 5). Estimates will be refined once load growth materializes.

<sup>32</sup> HVYTS - Replace T4 or T2 with an 83 MVA.

<sup>33</sup> HVYTS - Replace T4 or T2 with an 83 MVA.

MFATS2 - Replace both T1 and T2 with a 125 MVA.

## 1 7.2 Labrador West

2 The existing 230 kV transmission system has a non-firm winter capacity of 350 MW and is  
 3 adequate only if supply to industrial customers is restricted. System additions that would be  
 4 required to meet the unrestricted baseline load forecast of 383 MW are described in 5.2.1.  
 5 Hydro has conducted further analysis to determine the least-cost options incremental loading  
 6 scenarios given a significant potential for incremental load in Labrador West. This  
 7 comprehensive analysis is provided in Appendix B. Table 11 provides a summary of the  
 8 preferred alternatives.

**Table 11: Preferred Alternative for Incremental Lab West Load Levels**

Lab West Load (MW)	Least-Cost Option	Description of Alternative	Capital Cost (\$ million)
> 383	Alternative 5	<ul style="list-style-type: none"> <li>• Commissioning of SC3</li> <li>• Replacement of T4, T5, and T6 with 125 MVA units for loss of largest transformer</li> <li>• Replacement of four, 46 kV circuit breakers due to exceeding fault level</li> <li>• Installation of 72 MVARs of reactive compensation (needed for loss of SC#3)</li> <li>• Thermal Upgrade of L23/L24 to 75°C conductor temperature</li> </ul>	31.66
> 434	Alternative 17	<ul style="list-style-type: none"> <li>• Construction of 50 km of 315 kV transmission line from Bloom Lake, (“BLK”) to Flora Lake (“FLK”) and 5 km of 230 kV from FLK to WAB.</li> <li>• BLK 315 kV and WAB 230 kV Line Terminations</li> <li>• Construction of new 315/230/46 kV terminal station at FLK</li> <li>• Installation of four 40.2 MVAR capacitor banks on FLK 230 kV Bus</li> <li>• Commission synchronous condenser SC3</li> <li>• Upgrade of 14, 46 kV breakers with 2000 A, 31.5 kA breakers</li> <li>• 25 km of new 46 kV distribution lines plus upgrades to existing distribution lines</li> </ul>	153.15

1 **7.2.1 Considerations for an Interconnection to Hydro-Québec**

2 As per **Table 11**, if incremental loads are such that forecasted loads in Labrador West exceed  
3 434 MW, the least-cost alternative will involve an interconnection with Hydro-Québec at its  
4 Bloom Lake (“BLK”) Station.

5  
6 Hydro has been in consultation with Hydro-Québec TransÉnergie (“HQT”) with respect to  
7 interprovincial interconnection alternatives. These discussions have included cooperative  
8 transmission planning activities and have allowed for a shared understanding of commercial  
9 processes if such an interconnection were to be pursued.

10  
11 From a transmission planning perspective, a preliminary load flow study has been performed  
12 cooperatively by personnel from both utilities. The outcome of this analysis is that HQT has  
13 validated Hydro’s load flow models and analysis and has provided preliminary confirmation of  
14 the technical viability of the interconnection.

15  
16 From a commercial standpoint, personnel from HQT have informed Hydro that if the  
17 interconnection is to be pursued, a Transmission Service Request will need to be submitted.<sup>34</sup>  
18 This request will be for a point-to-point service to a new delivery point to be established at the  
19 border in western Labrador. This request will trigger the system impact study process.

20  
21 HQT further explained that study timelines are a function of the HQT study queue.<sup>35</sup> Once  
22 initiated, a system impact study will take a number of months, the duration of which will be a  
23 function of the impacts of the interconnection on HQT’s bulk transmission system. The system  
24 impact study will be followed by a facilities study that is anticipated to take a number of  
25 months.

---

<sup>34</sup> Costs associated with transmission tariffs would be identified during detailed discussions at that time.

<sup>35</sup> Due to the current backlog of queue requests, this wait time is in the range of several months to a year.

1 **8 Network Addition Policy Overview**

2 On October 1, 2018, Hydro submitted a network additions policy review to the Board. Hydro  
3 committed to file a proposal with the Board to deal with the assignment of cost responsibility  
4 for new network additions for the LIS by December 14, 2018.

5  
6 As evident from Section 7, the connection of a large customer can trigger the need for  
7 significant capital upgrades on the LIS. Consequently, there must be a mechanism in place to  
8 allocate any costs or benefits to the customer(s) advancing the need of a major capacity  
9 upgrade. Depending on the nature of the upgrade, other existing customers on the system can  
10 see reliability or economic benefits. Technical analysis will be required to quantify benefits  
11 using the principles defined in Hydro’s submission to the Board on October 1, 2018.

12  
13 This Expansion Study includes a summary of the LIS expansion requirements to meet the  
14 baseline forecast. It also includes descriptions of the incremental expansion requirements to  
15 accommodate the interconnection of additional major customer loads beyond the baseline  
16 forecast. The application of principles supporting the beneficiary pays approach in dealing with  
17 the assignment of cost responsibility will therefore involve a comparison of these scenarios.

18  
19 The detailed technical analysis for beneficiary pays considerations such as reliability  
20 improvements will depend on the timing and magnitude of specific customer interconnection  
21 requests. Future major load requests that have an appreciable impact to the baseline  
22 transmission system expansion plan will therefore be subject to a system impact study.  
23 Network addition principles will be applied using technical analysis and proposed cost  
24 allocations will be presented to the Board for review and approval.

25  
26 Further details relating to the application of the Network Addition Policy for the LIS will be  
27 provided to the Board in December 2018.

## 9 Customer Rate Impacts

There is significant uncertainty with respect to specific customer rate impacts associated with the expansion of the transmission system in Labrador. As presented in Section 7, the size and timing of customer requests will have a significant impact on expansion requirements. Further, the application of the Network Addition Policy has the potential to impact cost allocations to ensure fairness. It is only by performing a detailed system impact study in response to a specific customer request that such rate calculations can be performed.

For the purposes of this Expansion Study, Figure 6 has been provided as a basis for the generic calculation of forecast rate impacts for rural and industrial customers in Labrador as a function of the capital costs of a transmission system expansion.

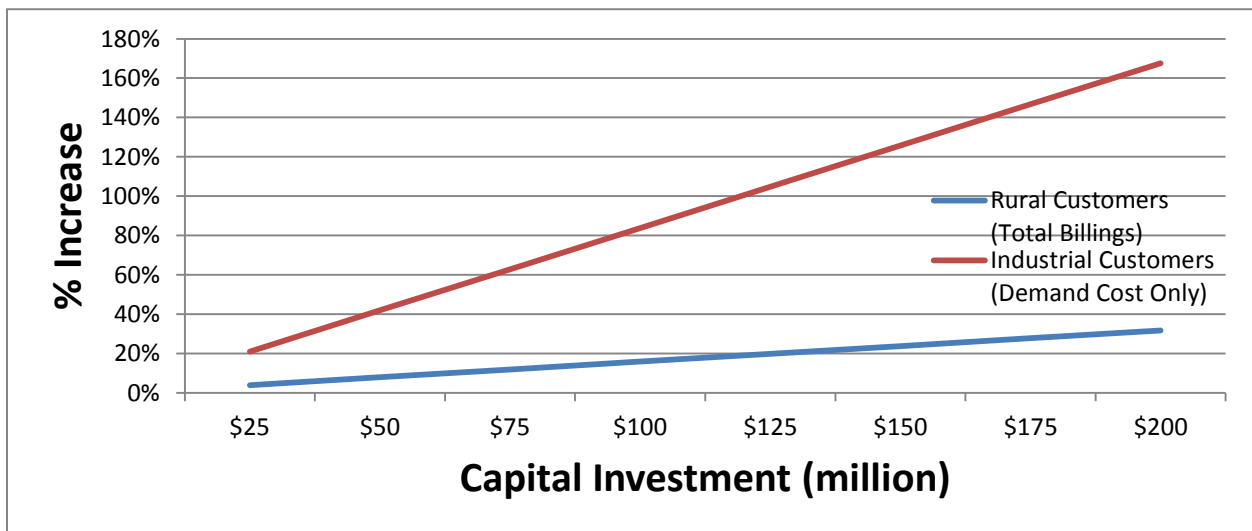

Figure 6: Projected Rate Increase vs. Capital Investment

## 10 Further Options for Reliability Improvement

In addition to the transmission expansion alternatives presented in this report, Hydro has identified further reliability improvements for the LIS that will be investigated and further discussed with Labrador customers. These include:

1       • **Addition of lightning arresters on 230 kV lines L23 and L24**

2           This project involves the addition of lightning arresters to the transmission lines as was  
3           performed on transmission line TL 206 between Bay d’Espoir Terminal Station and  
4           Sunnyside Terminal Station.

5       • **Reconfiguration of the Churchill Falls Terminal Station**

6           This project involves the reconfiguration of 230 kV buses at Churchill Falls Terminal  
7           Station to facilitate equipment maintenance. Under the current scheme, maintenance  
8           to a number of buses and disconnect switches requires an outage to the entire  
9           transmission system in western Labrador.

10      • **Addition of a second 46 kV radial line to Wabush Substation**

11           As discussed in Section 4.3, L36 is a radial line to the Wabush Substation and an outage  
12           to this line may result in an outage to over 20 MW of customer load.

13  
14   The detailed review of these alternatives is beyond the scope of this investigation. Hydro will  
15   develop cost estimates and quantify reliability improvements associated with each for inclusion  
16   in future capital budget applications as appropriate. Hydro also plans to perform a reliability  
17   assessment for the 230 kV lines to Labrador West. The approach to this assessment will be  
18   comparable to the assessment contained in Appendix E.

19  
20   **11 Conclusion and Recommendations**

21   The primary objective of this report is to provide a comprehensive outlook of the LIS reflecting  
22   baseline forecasts. This Expansion Study lays out the long-term plan for the LIS for both normal  
23   and accelerated load growth in Labrador.

24  
25   **11.1 Recommendations to Meet Baseline Load Requirements**

26   The following is a consolidation of all the recommendations formulated by Hydro to meet  
27   baseline load forecast requirements:

- 28       • The approval of the Muskrat Falls to Happy Valley Interconnection project as outlined in  
29       Section 5.1.2. The economic analysis in Section 6.1.1 demonstrates that this is the least-

1 cost option to accommodate the expected load growth of the Happy Valley area over  
2 the next 25 years.

- 3 • The submittal of a capital proposal as part of the 2020 Capital Budget Application (or  
4 sooner) to upgrade transmission system capacity in western Labrador as per upgrades  
5 outlined in Section 5.2.1. In the near term, Hydro will explore opportunities to  
6 accelerate the commissioning of Synchronous Condenser #3 to avoid industrial  
7 customer load curtailment in 2019 with all equipment in service.
- 8 • The submittal of a capital proposal as part of the 2020 Capital Budget Application to  
9 upgrade the Wabush Substation as per the three transformer configuration outlined in  
10 Section 5.3.2.
- 11 • The submittal of a capital proposal as part of the 2020 Capital Budget Application to  
12 upgrade the 46 kV transmission system as defined in Section 4.3.
- 13 • The application of a network additions policy that allocates the advancement costs and  
14 benefits associated with capacity upgrades within the LIS. This report includes  
15 transmission system expansion plans for baseline load forecasts. Cost and benefit  
16 allocations will be calculated on the basis of how the interconnection of major  
17 incremental loads will result in deviations from the baseline expansion plan.

## 19 **11.2 Recommendations to Meet Incremental Load Requests**

20 The following recommendations are made with respect to system expansion requirements to  
21 meet incremental load requests above the baseline schedule.

22  
23 For Labrador East:

- 24 • Labrador East Load Exceeds 104 MW<sup>36</sup>
  - 25 ○ Transformation Upgrade at HVYTS
- 26 • Labrador East Load Exceeds 125 MW<sup>37</sup>
  - 27 ○ Transformation Upgrades at HVYTS and MFATS2

---

<sup>36</sup> Approximation that does not include capacity from HVYGT.

<sup>37</sup> Ibid.



- 1 • Labrador East Load Exceeds 162 MW<sup>38</sup>
- 2 ○ Construction of Second Line from MFATS2 to HVY

3

4 The determination of specific MW limits is subject to optimization analyses involving the rental  
5 or purchase of backup generation, the establishment of interruptible arrangements, or the  
6 advancement of a second transmission line to Happy Valley-Goose Bay. Such analyses will be  
7 assessed in impact studies performed in response to specific customer requests.

8

9 For Labrador West:

- 10 • Labrador West load exceeds 383 MW:
  - 11 ○ Work with IOC on the commissioning of SC#3 and 30 MVAR reactor;
  - 12 ○ Replacement of T4, T5, and T6 with 125 MVA units for loss of largest transformer;
  - 13 ○ Replacement of four 46kV circuit breakers due to exceeding fault level;
  - 14 ○ Installation of 72 MVARs of reactive compensation (needed for loss of SC#3);
  - 15 ○ Thermal Upgrade of L23/L24 to 75°C conductor temperature;
  - 16 ○ System study for capacitor bank addition with possible future addition of another 49
  - 17 MVARs on the 46 kV bus; and
  - 18 ○ Complete terminal station condition assessment.
- 19
- 20 • Labrador West exceeds 434 MW:
  - 21 ○ Construction of 50 km of 315 kV transmission line from Bloom Lake Station to Flora
  - 22 Lake Station and 5 km of 230 kV transmission line from Flora Lake Station to Wabush
  - 23 Terminal Station;
  - 24 ○ New 315/230/46 kV terminal station at Flora Lake complete with 73 MVAR capacitor
  - 25 banks;
  - 26 ○ Work with IOC on commissioning of SC#3;
  - 27 ○ Replacement of T4, T5, and T6 with 125 MVA units for loss of largest transformer;

---

<sup>38</sup> Ibid.

- 1       ○ Replacement of 15 - 46 kV circuit breakers due to exceeding fault level;
- 2       ○ New 230 kV line termination at Wabush Terminal Station; and
- 3       ○ 315 kV Line termination at Bloom Lake (HQ).





**Appendix A**

Future Supply of Labrador East – Phased Approach  
Transmission System Analysis



## **Future Supply of Labrador East – Phased Approach**

### **Transmission System Analysis**

#### **1 Purpose**

2 An analysis was performed to assess the long term plan for the Happy Valley-Goose Bay system  
3 in the event of incremental load growth on the Labrador Interconnected system in excess of the  
4 baseline forecast.

5

#### **6 Introduction**

7 The existing 138 kV transmission system configuration serving the Happy Valley-Goose Bay  
8 (“HVGB”) area is capable of delivering 77 MW to the 25 kV bus at the Happy Valley Terminal  
9 Station (“HVTYS”). For load levels beyond 77 MW, system voltages levels will rapidly decline,  
10 ultimately resulting in system voltage collapse and customer outages. The most recent P90  
11 peak load forecast indicates that Happy Valley demand is expected to exceed 77 MW by the  
12 winter of 2018-2019. Table 1 provides a summary of the baseline forecast.

13

14 Hydro is currently in the process of seeking approval to execute a project that will address this  
15 capacity deficit by interconnecting HVGB to Muskrat Falls 315 kV Terminal Station 2  
16 (“MFATS2”). It has been proposed to reconfigure the termination of Transmission Line L1302 at  
17 Muskrat Falls Station (“MFATS3”) to allow for the interconnection of a 6 km segment of 138 kV  
18 wood pole transmission line to be constructed to MFATS2. MFATS2 has been designed with  
19 provision to provide two, 138 kV supply connections via 315/138 kV, 125 MVA transformers. A  
20 new 138/25 kV, 50 MVA transformer was also proposed as part of the capital project that  
21 would also have to be installed at the HVTYS to provide additional transformation for the  
22 projected load increase.

**Table 1: Happy Valley-Goose Bay Area - Baseline Coincident Peak Forecast**

<b>Year</b>	<b>Base Coincident Peak (MW)</b>
2018	81.7
2019	83.3
2020	83.5
2021	83.8
2022	84.0
2023	84.3
2024	84.9
2025	85.4
2026	85.9
2027	86.4
2028	86.9
2029	87.5
2030	88.0
2031	88.5
2032	89.0
2033	89.6
2034	90.1
2035	90.6
2036	91.1
2037	91.7
2038	92.2
2039	92.7
2040	93.3
2041	93.8
2042	94.3
2043	94.8

1 With the completion of the proposed interconnection project, the system capacity increases to  
2 104 MW (or 106 MVA),<sup>1</sup> this would be limited by the transformation capacity at the HVYTS  
3 following the installation of the new 50 MVA transformer. An additional 25 MW of capacity is  
4 also available with the operation of the Happy Valley Gas Turbine (“HVYGT”). Based on the  
5 baseline forecast, this new configuration would support peak demand in HVGB for at least the  
6 next 25 years. Figure 1 is a simplified single-line diagram of the Labrador East system after the  
7 completion of the Muskrat Falls to Happy Valley-Goose Bay Interconnection, if approved.

<sup>1</sup> 28 MVA + 28 MVA + 50 MVA = 106 MVA.



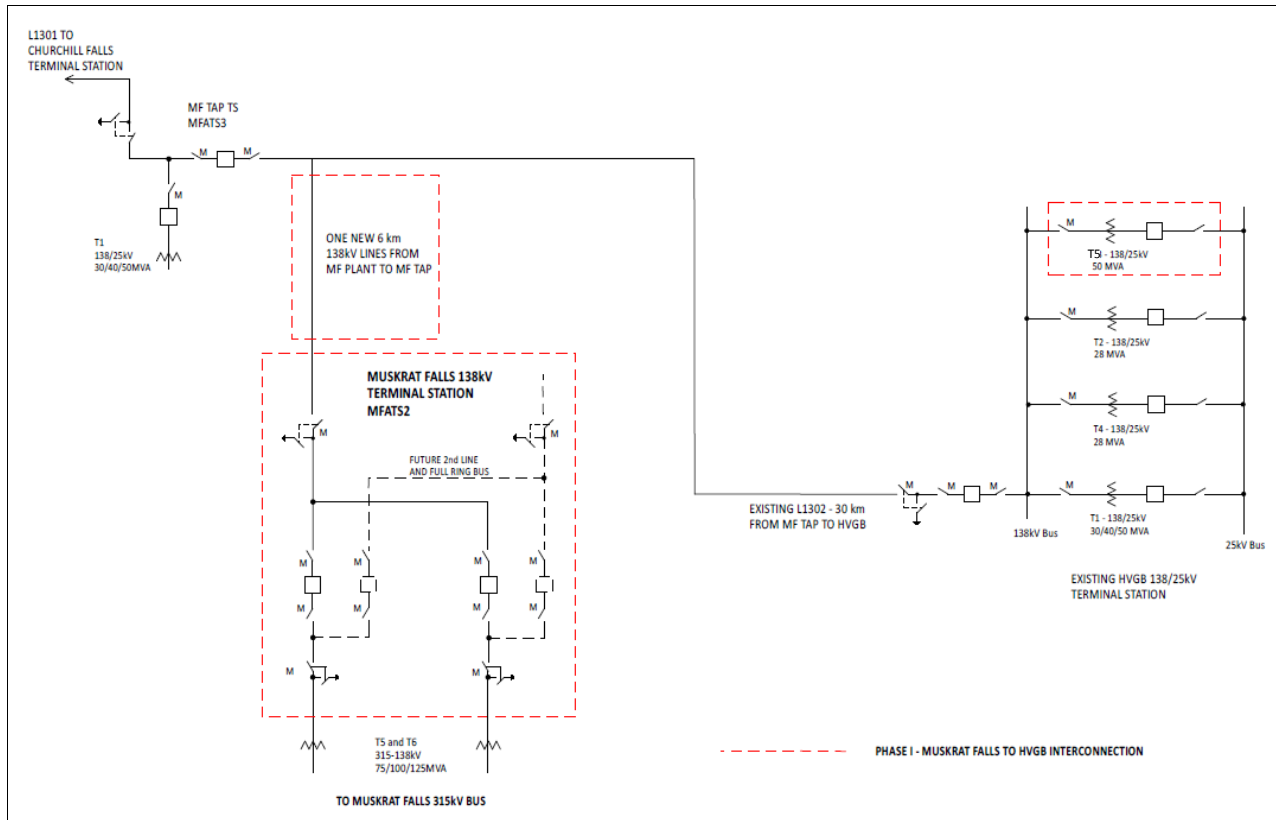

**Figure 1: Muskrat Falls to Happy Valley Interconnection**

1 **Impact of Sudden Load Growth in HVGB**

2 Given the current economic environment in Labrador with low electricity rates , there is a high  
 3 likelihood of unforeseen load growth in the HVGB area. An initiative has therefore been  
 4 undertaken to assess the impact of load growth beyond the baseline forecast. Such loads  
 5 would include new large customers such as data centres and/or the possibility of a Central  
 6 Heating Plant Conversion at the Department of National Defense (DND) facility. Hydro’s plan  
 7 will involve a phased approach depending on the magnitude of incremental load growth in  
 8 HVGB.

9

10 Hydro has prepared a sensitivity forecast from 2018 to 2043 that provides the possible  
 11 incremental load growth associated with data centre development and DND’s plant conversion.

- 1 The sensitivity forecast is shown in Table 2. The load forecast is assumed to be flat beyond the  
2 year 2028.

**Table 2: Sensitivity Incremental Forecast (2018-2028)**

	2018	2019	2020	2021	2022	2023	2024	2025	2026	2027	2028
<b>Labrador East Data Center Development Case</b>											
Customer Peak (kW) <sup>1</sup>	0	0	14,961	22,442	29,923	29,923	29,923	29,923	29,923	29,923	29,923
CP at Labrador East Peak (kW) <sup>2</sup>	0	0	14,213	21,320	28,427	28,427	28,427	28,427	28,427	28,427	28,427
CP at LIS Peak (kW) <sup>3</sup>	0	0	14,213	21,320	28,427	28,427	28,427	28,427	28,427	28,427	28,427
<b>Labrador East DND Central Heating Plant Conversion Case</b>											
Customer Peak (kW) <sup>1</sup>	0	0	12,000	12,000	12,000	12,000	12,000	12,000	12,000	12,000	12,000
CP at Labrador East Peak (kW) <sup>2</sup>	0	0	12,000	12,000	12,000	12,000	12,000	12,000	12,000	12,000	12,000
CP at LIS Peak (kW) <sup>3</sup>	0	0	10,560	10,560	10,560	10,560	10,560	10,560	10,560	10,560	10,560

Notes:

1. Peak requirements reflect requirements at terminal station delivery points.
2. Peak requirements at terminal station delivery points coincident with region peak.
3. Peak at terminal station delivery points coincident with Labrador Interconnected System (LIS) peak.
4. DND central heating plant conversion loads estimated at 12 to 15 MW by DND.

Source: Market Analysis Section, Rural Planning Department

3 When adding the incremental load forecast in Table 2 to Table 1, the demand in HVGB for the  
4 year 2022 could reach 123 MW (or approximately 125 MVA).<sup>2</sup> The Muskrat Falls to Happy  
5 Valley Interconnection, or Phase 1 of the HVGB long-term plan, would only provide 104 MW of  
6 capacity. An additional 20 MW of transformer capacity at HVY would therefore be required. It is  
7 proposed that Phase 2 would involve the replacement of T2 or T4 with a 83 MVA<sup>3</sup> transformer  
8 to increase the transformation capacity of the HVYTS to 128 MVA<sup>4</sup> (or 126 MW).

9  
10 If the total peak demand at HVGB exceeds 125 MVA, Phase 3 of the long-term plan would be  
11 initiated and would require incremental transformation capacity at HVYTS and MFATS2. There  
12 are currently two transformers in the MFATS2 designed to provide station service to the  
13 Muskrat Falls Generation Station. Each of these two transformers are equipped with a 138 kV  
14 winding rated for 125 MVA. To ensure sufficient capacity in the event of an outage, the 125

<sup>2</sup> 28.4 MW + 10.6 MW + 84.0 MW = 123 MW.

<sup>3</sup> Standard transformer size.

<sup>4</sup> 28 MVA + 50 MVA + 50 MVA = 128 MVA.

1 MVA transformers would be replaced with two, 250 MVA transformers, increasing the firm  
 2 transformation capacity at MFATS2 to 250 MVA. A total customer demand of 125 MW in HVGB  
 3 would also trigger the need to increase transformation at the HVYTS, since the transformation  
 4 capacity would be approximately 125 MW at this stage. Transformer T2 or T4 at the HVYTS  
 5 would have to be replaced with an 83 MVA unit at the HVYTS, increasing the firm  
 6 transformation capacity to 183 MVA<sup>5</sup>.

7  
 8 The final phase of the long-term plan for HVGB would require the construction of a second, 30  
 9 km, 138 kV line from MFATS2 to HVYTS. This project would be triggered if the demand in HVGB  
 10 were to exceed 162 MW, which is the thermal rating of L1302.

11  
 12 Table 3 provides a brief summary of each phase of the HVGB long-term plan, including the  
 13 HVGB demand that initiates their requirement and a high level cost estimate (Class 5). Table 3  
 14 does not include the additional capacity that could be provided by the HVYGT.

**Table 3: Labrador East – Proposed Future Phases**

Phase	HVY Load that would Initiate Project (MW) <sup>6</sup>	Project Description	Cost Estimate <sup>7</sup> (\$ million)
1	>77	<b>Muskrat Falls to Happy Valley Interconnection</b>	20.0
2	>104	<b>Transformation Upgrade at HVYTS</b> (Replace T2 or T4 with a 83 MVA unit)	5.0
3	> 125	<b>Transformation Upgrade at HVYTS and MFATS2</b> (HVYTS: Replace T2 or T4 with a 83 MVA unit) (MFA TS2: Replace both T1 and T2 with two 250 MVA units)	15.0
4	>162	<b>Construction of Second Line from Muskrat Falls to Happy Valley</b>	50.0

<sup>5</sup> 50 MVA + 50 MVA + 83 MVA = 183 MVA.

<sup>6</sup> Specific limits would depend on the technical requirements driven by future customer requests.

<sup>7</sup> Estimates would be refined once load growth materializes.

1 **Long Term Considerations for the HVYGT**

2 The capacity provided by the HVYGT is a source of supply for HVGB during planned and  
3 unplanned outages. Every summer there is a planned outage on L1302 for maintenance. With  
4 L1302 out of service, power must be supplied by the HVYGT. The HVYGT is capable of supplying  
5 approximately 22 MW in summer conditions, requiring Hydro to schedule maintenance during  
6 the lightest load conditions. In the event that the HVGB load increases to a point where outage  
7 windows cannot be coordinated, additional backup generation and/or customer interruption  
8 arrangements would be required. Optimization analyses relating to the rental or purchase of  
9 backup generation, the establishment of interruptible arrangements, or the advancement of  
10 second transmission line to HVGB would be assessed in impact studies performed in response  
11 to specific customer requests.

12  
13 The HVYGT also has potential to become an important source of capacity as load continues to  
14 grow within the Labrador Interconnected System (LIS). Hydro is currently entitled to  
15 approximately 532 MW of recall capacity at the Churchill Falls Generation Station. According to  
16 the baseline forecast and excluding the capacity of the HVYGT, it is projected that the amount  
17 of available recall would be reduced to approximately 16 MW by the year 2043.

18  
19 Given the magnitude of potential incremental load beyond the baseline forecast in both  
20 eastern and western Labrador, the installed capacity of the HVYGT may be required to meet  
21 peak LIS load in the near term. On this basis, this unit could remain in place even in the event of  
22 the construction of the second line to HVGB. This is the case as the magnitude of incremental  
23 load to trigger the installation of the second line would potentially coincide with a requirement  
24 for additional LIS capacity. As is the case for transmission system expansion, optimization  
25 analyses to be performed as part of generation planning studies would be performed on the  
26 basis of specific customer requests.

1   **Recommendations**

2   The following are recommendations with respect to system expansion requirements to meet  
3   incremental load requests above the baseline schedule for HVGB.

- 4       • HVGB Load Exceeds 77 MW:<sup>8</sup>
  - 5           ○ Complete the proposed Muskrat Falls to Happy Valley Interconnection Project.
- 6       • HVGB Load Exceeds 104 MW:<sup>8</sup>
  - 7           ○ Transformation Upgrade at HVYTS. The replacement of T2 or T4 with an 83 MVA
  - 8           transformer.
- 9       • HVGB Load Exceeds 125 MW:<sup>8</sup>
  - 10           ○ Transformation Upgrade at HVYTS. The replacement of T2 or T4 with an 83 MVA
  - 11           transformer; and
  - 12           ○ Transformation Upgrade at MFATS2. The replacement of both 125 MVA
  - 13           transformers with 250 MVA transformers.
- 14       • HVGB Load Exceeds 162 MW
  - 15           ○ Construction of Second Line from MFATS2 to Happy Valley

---

<sup>8</sup> The figures provided above are approximations that do not include capacity from the HVYGT. The determination of specific MW limits is subject to optimization analyses involving the rental or purchase of backup generation, the establishment of interruptible arrangements, or the advancement of second transmission line to HVGB. Such analyses would be assessed in impact studies performed in response to specific customer requests.









**Appendix B**

Transmission System Analysis - Future Supply of Labrador West



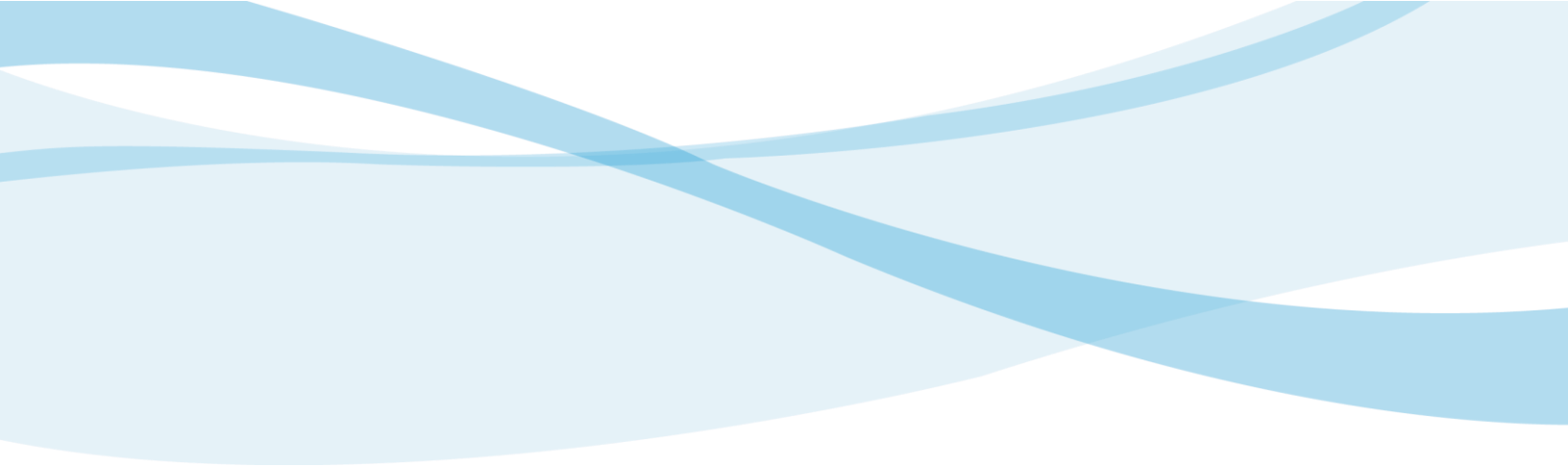

Transmission System Analysis  
Future Supply of Labrador West

October 2018

*A Report to the Board of Commissioners of Public Utilities*



## Table of Contents

1	Summary .....	1
2	Existing System .....	3
	2.1 Transmission System.....	3
	2.2 Wabush Terminal Station .....	3
	2.3 Labrador West 46 kV Transmission System.....	4
	2.4 Existing Customers.....	4
	2.5 Power Transfer Capability.....	6
	2.6 46 kV Circuit Breaker Ratings.....	7
	2.7 Synchronous Condenser SC3 .....	8
3	Load Forecast .....	8
4	Interconnection Alternatives .....	10
5	Lifecycle Cost Analysis.....	12
	5.1 Transmission System Losses Impact .....	12
	5.1.1 Transmission System Losses Churchill Falls to Labrador West.....	12
	5.2 Operation and Maintenance Cost Assumptions.....	13
	5.3 Cost Benefit Analysis.....	13
6	Conclusions and Recommendations.....	15

## List of Appendices

- Appendix A: Labrador West Future Transmission Supply Alternatives
- Appendix B: Labrador West Future Transmission Supply Alternatives Single-Line Diagrams
- Appendix C: Labrador West Transmission Loss Analysis
- Appendix D: Operating and Maintenance Assumptions for Alternatives
- Appendix E: Voltage Conductor Selection

1 **1 Summary**

2 An analysis was performed to develop expansion plans for the transmission system in western  
3 Labrador. The objective of the study was to develop technically viable alternatives for the range  
4 of load forecasts for a 25-year study period that extends to 2043.

5

6 The following forecasts were considered for this investigation:

- 7 1) Baseline Load Forecast: 383 MW;
- 8 2) Low Incremental Load: up to 434 MW; and,
- 9 3) High Incremental Load: exceeds 434 MW.

10

11 Load flow analyses were performed to identify required upgrades for each interconnection  
12 alternative and single-line diagrams were developed as a basis of cost estimate. A total of 17  
13 alternatives were defined.

14

15 Lifecycle cost analyses were performed to assess each load forecast category. Consideration  
16 was given to capital costs, transmission system loss impacts, and operating and maintenance  
17 costs. The results of the analysis indicate that the preferred solutions are as provided in Table 1.

**Table 1: Analysis Cost Breakdown**

Forecast	Preferred Alternative No.	Alternative Description	Estimated Cost (\$ million)
Baseline (383 MW)	4	WTS <sup>1</sup> Upgrades for Baseline Load 46 kV Transmission Line Upgrades <sup>2</sup>	15.1 1.4
Medium Incremental (up to 434 MW)	5	WTS Upgrades for Incremental Load	31.7
High Incremental (>434 MW)	17	315kV Transmission Line from BLK <sup>3</sup> to FLK <sup>4</sup> with 46 kV Connection from FLK	153.2

1 Recommended transmission system expansions are therefore summarized as follows:

2 • Baseline: Labrador West load up to 383 MW:

- 3 ○ reconductoring of 46 kV transmission lines for supply to Hydro Rural customers;
- 4 ○ commissioning of Synchronous Condenser No. 3 (“SC3”) and 30 MVAR reactor;
- 5 ○ replacement of transformers T4 and T5 with 125 MVA units;
- 6 ○ replacement of four, 46 kV circuit breakers due to exceeding fault level;
- 7 ○ installation of 23 MVARs of capacitors on 46 kV bus (needed for loss of SC3);
- 8 ○ system study for capacitor bank addition with possible future addition of another 49
- 9 MVARs on the 46 kV bus; and
- 10 ○ terminal station condition assessment.

11 • Low Incremental: Labrador West load exceeds 383 MW, up to 434 MW:

- 12 ○ commissioning of SC3 and 30 MVAR reactor;
- 13 ○ replacement of T4, T5, and T6 with 125 MVA units for loss of largest transformer;
- 14 ○ replacement of four, 46 kV circuit breakers due to exceeding fault level;
- 15 ○ installation of 72 MVARs of reactive compensation (needed for loss of SC3);

<sup>1</sup> Wabush Terminal Station (“WTS”).

<sup>2</sup> 46 kV line upgrades are included in all scenarios and as discussed in *Labrador West 46 kV System Expansion – Existing 46 kV System and Future Alternatives, TP-R-024*, Hydro, October 2018.

<sup>3</sup> Bloom Lake (“BLK”).

<sup>4</sup> Flora Lake (“FLK”).

- 1       ○ thermal upgrade of L23/L24 to 75°C conductor temperature;
- 2       ○ system study for capacitor bank addition with possible future addition of another 49
- 3       MVARs on the 46 kV bus; and
- 4       ○ terminal station condition assessment.
- 5       ● High Incremental: Labrador West load exceeds 434 MW:
- 6       ○ construction of 50 km of 315 kV transmission line from Bloom Lake (“BLK”) Station
- 7       to Flora Lake (“FLK”) Station and 5 km of 230 kV transmission line from FLK Station
- 8       to Wabush Terminal Station (“WTS”);
- 9       ○ new 315/230/46 kV terminal station at FLK complete with 73 MVAR caps;
- 10      ○ commissioning of SC3;
- 11      ○ replacement of T4, T5, and T6 with 125 MVA units for loss of largest transformer;
- 12      ○ replacement of 15, 46 kV circuit breakers due to exceeding fault level;
- 13      ○ new 230 kV line termination at WTS; and
- 14      ○ 315 kV line termination at BLK.

15

## 16 **2 Existing System**

17 Figure 1 provides a single-line diagram of the existing Labrador West Transmission System. The  
18 components are described as follows:

19

### 20 **2.1 Transmission System**

- 21       ● Two, 230 kV transmission lines from Churchill Falls to Wabush, a distance of 217 km;
- 22       ● each transmission line consists of steel structures with a single 636 kcmil, 26/7, ACSR
- 23       “GROSBEAK” conductor per phase; and
- 24       ● each transmission line has thermal limits of 439 A @ 30°C, 650 A @ 15oC, and 934 A @ -
- 25       15°C ambient based upon a 50°C conductor temperature.

26

### 27 **2.2 Wabush Terminal Station**

- 28       ● Station configured in load bus arrangement with two main 46 kV buses and a normally
- 29       open 46 kV bus tie circuit breaker;

- 1 • six, 230/46 kV, 35/47/58/65 MVA power transformers (three per 46 kV bus) numbered
- 2 T1 through T6;
- 3 • two, 230/46 kV, 50/66.7/83.3 MVA power transformers (one per 46 kV bus) numbered
- 4 T7 and T8;
- 5 • two, -40/+60 MVAR Synchronous Condensers No. 1 (“SC1”) and No. 2 (“SC2”);
- 6 • two, 25.2 MVAR, 46 kV Capacitor Banks No. 1 (“C1”) and No. 2 (“C2”); and
- 7 • two, 46 kV grounding/station service transformers (one per 46 kV bus) with a third
- 8 ground point from one of the 50/66.7/83.3 MVA power transformers (T8).

### 9 **2.3 Labrador West 46 kV Transmission System<sup>5</sup>**

- 10 • 46kV to the towns of Wabush and Labrador City, as well as to industrial customer the
- 11 Iron Ore Company of Canada (“IOC”); and
- 12 • 46 kV transmission lines L32, L40, and L33 connect customers in Labrador City, and the
- 13 46 kV transmission line L36 connects customers in the Town of Wabush.

14

### 15 **2.4 Existing Customers**

16 The Existing Labrador West Transmission System supplies three customers under normal  
17 operation:

- 18 • IOC;
- 19 • Wabush Mines (“WM”) – operated by Tacora Ltd;<sup>6</sup> and
- 20 • Newfoundland and Labrador Hydro (“Hydro”) which serves the towns of Labrador City
- 21 and Wabush.

---

<sup>5</sup> An overview and analysis of the 46 kV system is provided in *Labrador West 46 kV System Expansion – Existing 46 kV System and Future Alternatives, TP-R-024*, Hydro, October, 2018

<sup>6</sup> For the purposes of this investigation, the baseline load forecast includes load increases associated with Tacora operation at the Wabush Mines site. Hydro currently receives monthly power on order requests to accommodate the ramp up of this operation. The transmission system expansion plans developed in this report are designed to accommodate the full operation of this facility.



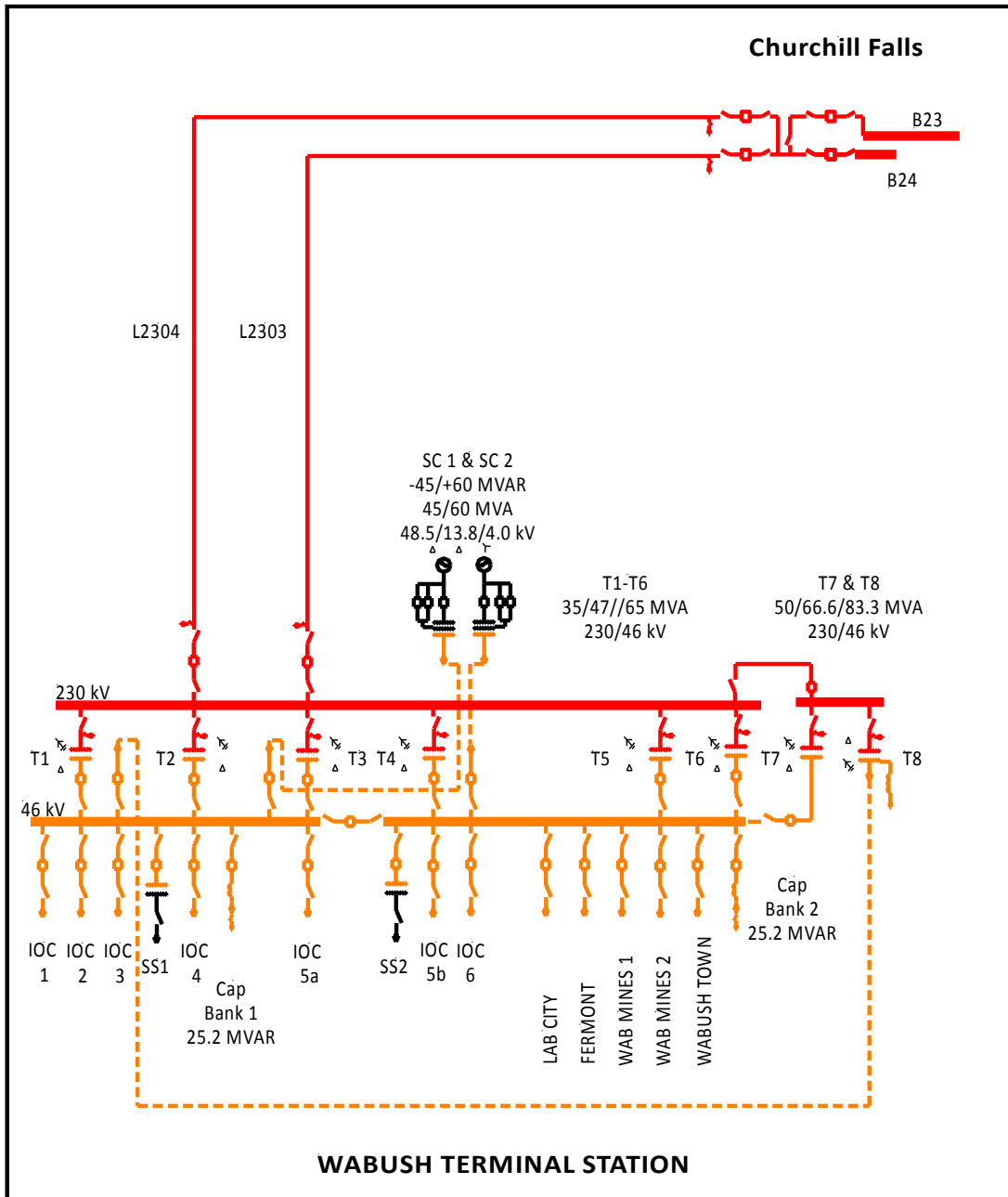

Figure 1: Existing Labrador West Transmission System

1 **2.5 Power Transfer Capability**

2 The transfer capability of the existing Labrador West Transmission System, with Churchill Falls  
3 230 kV bus held at 238 kV, is summarized as follows:

- 4 • winter limitation with all equipment in service: 350.0 MW (limitations due to voltage  
5 constraints);
- 6 • winter limitation with L23 or L24 out of service: 252.0 MW (limitations due to voltage  
7 constraints);
- 8 • summer limitation with all equipment in service: 324.0 MW (thermal limitations due to  
9 overloading of L23 and L24);
- 10 • summer limitation with L23 or L24 out of service: 164.0 MW (thermal limitations due to  
11 overloading of L23 and L24);
- 12 • loss of T7 power transformer: 111 percent load on the remaining 3 units. A combined  
13 19.5 MW load reduction by both Hydro and IOC on Bus No. 2 (“B2”) will reduce the T4  
14 to T6 loading to 100 percent. Another possibility would be to transfer 12 MW of IOC  
15 load from B2 to Bus No. 1 (“B1”) for a maximum transfer of 345 MW for which a voltage  
16 limitation would exist on the Synchronous Condensers (“SC’s”) terminal voltage;
- 17 • loss of T8 power transformer: no transformer overloads but SC1 and SC2 at maximum  
18 terminal voltage of 1.05 pu. Maximum transfer capability is 345.2 MW;
- 19 • loss of C1: A 11 MW load reduction by IOC on B1 and a 10 MW load reduction on B2 will  
20 be required to maintain 46 kV bus voltages of 46.6 kV. Limitation is maximum terminal  
21 voltage on SC1 and SC2 at 1.05pu. The maximum transfer with C1 out is 329 MW;
- 22 • loss of C2: A 19 MW load reduction by IOC on B1 and a 15 MW load reduction on B2 will  
23 be required to maintain 46 kV bus voltages of 46.6 kV. Limitation is maximum terminal  
24 voltage on SC1 and SC2 at 1.05pu. The maximum transfer with C2 out is 316 MW;
- 25 • loss of SC1: With the bus tie open a 41 MW load reduction by IOC on B1 and 11 MW  
26 reduction on B2 is required to give acceptable voltages and a maximum power transfer  
27 of 298 MW. With bus tie closed a 44 MW load reduction by IOC and Hydro on B1 and B2  
28 are required to give a maximum transfer of 306 MW; and

- 1       • loss of SC2: With the bus tie open a 60 MW load reduction by Hydro and IOC on B2 is  
2       required for a maximum transfer of 290 MW. With the bus tie closed the maximum  
3       transfer capability is 305 MW.

4  
5 To increase the firm transmission capability of the system beyond 350 MW new transmission  
6 infrastructure would be required. In the absence of such an interconnection, a customer load  
7 reduction strategy has been adopted where partial service is provided during equipment  
8 outages on the Labrador West Transmission System.

## 10 **2.6 46 kV Circuit Breaker Ratings**

11 Of the 12, 46 kV circuit breakers connected to 46 kV B1, ten circuit breakers have an  
12 interrupting rating of 1500 MVA and the remaining two circuit breakers have interrupting  
13 ratings of 1990 MVA and 2500 MVA.

14  
15 Of the 14, 46 kV circuit breakers on 46 kV B2, three circuit breakers have an interrupting rating  
16 of 1500 MVA, one breaker is rated 1590 MVA, eight breakers are rated 2000 MVA, and two  
17 breakers are rated 2500 MVA.

18  
19 The 46 kV bus tie circuit breaker 46-11 has an interrupting rating of 1735 MVA.

20  
21 The three-phase short circuit levels on 46 kV B1 and B2 are 1403 MVA and 1186 MVA  
22 respectively. Given the 1500 MVA interrupting rating on the majority of the 46 kV circuit  
23 breakers connected to B1, operation of the WTS with the 46 kV bus tie circuit breaker closed  
24 and both synchronous condensers in service is prohibited. In fact, to operate with the 46 kV bus  
25 tie circuit breaker closed at least one synchronous condenser must be shut down, at least one  
26 of the 50/66.6/83.3 MVA transformers and two of the 35/47/58/65 MVA transformers must be  
27 removed from service in order to reduce the three phase short circuit level on the combined 46  
28 kV bus to 1505 MVA.

1 **2.7 Synchronous Condenser SC3**

2 In 2013 IOC installed a third synchronous condenser (SC3) at the WTS, but it was not  
3 commissioned and currently is not in service.<sup>7</sup> This unit will be able to provide the necessary  
4 voltage support to increase the WTS load to a maximum of 387 MW<sup>8</sup> in total. Given the  
5 increase in short circuit levels associated with the addition of SC3 and the limited interrupting  
6 capabilities of the 46 kV circuit breakers on 46 kV B1, the new synchronous condenser will be  
7 connected in parallel to SC2 on 46 kV B2 under normal operation. SC3 will only be connected to  
8 B1 when SC1 is out of service.

9

10 **3 Load Forecast**

11 For the purposes of this investigation, a baseline load forecast has been considered, as well as a  
12 sensitivity case that considers loads to ensure supply for customer loads including Hydro Rural,  
13 IOC, Tacora, Alderon, and data centres without load interruption when all equipment is in  
14 service. This load forecast, released in July 2018 is provided in Table 2.

---

<sup>7</sup> This unit is owned by IOC and a commercial arrangement would be required for this unit to be placed in service.

<sup>8</sup> The maximum transfer capability of the existing Labrador West Transmission System with SC3 in service is dependent, in part, on the power factor of the connected load.

**Table 2: Western Labrador Load Forecast (MW)**

Year	Baseline Peak <sup>9</sup>	Data Centre	Coincid. Peak with Data Centres	Coincid. Peak with Alderon
2018	342.4	0	342.4	342.4
2019	358.4	0	358.4	358.4
2020	369.0	27.1	396.0	396.0
2021	377.1	40.6	417.7	417.7
2022	377.3	51.5	428.8	493.8
2023	377.6	51.5	429.1	494.1
2024	377.9	51.5	429.4	494.4
2025	378.2	51.5	429.7	494.7
2026	378.5	51.5	430.0	495.0
2027	378.8	51.5	430.3	495.3
2028	379.1	51.5	430.6	495.6
2029	379.4	51.5	430.8	495.8
2030	379.6	51.5	431.1	496.1
2031	379.9	51.5	431.4	496.4
2032	380.2	51.5	431.6	496.6
2033	380.5	51.5	431.8	496.8
2034	380.7	51.5	432.1	497.1
2035	381.0	51.5	432.3	497.3
2036	381.2	51.5	432.6	497.6
2037	381.4	51.5	432.8	497.8
2038	381.7	51.5	433.1	498.1
2039	381.9	51.5	433.3	498.3
2040	382.2	51.5	433.6	498.6
2041	382.4	51.5	433.8	498.8
2042	382.7	51.5	434.1	499.1
2043	382.9	51.5	434.3	499.3

- 1 A plot of historical 46 kV feeder power factors versus load is provided in Figure 2. The plot
- 2 indicates a relatively high power factor for Hydro loads over peak. This is consistent with a high
- 3 penetration of electric heat. For analysis purposes the peak load power factor for Hydro load in
- 4 Labrador West is set at 0.975 as reactive power consumption in the 46 kV transmission system
- 5 will increase with increased line loading.

<sup>9</sup> The baseline peak load forecast includes loads for Hydro Rural, IOC, and Tacora. Under existing system conditions, power on order for IOC and Tacora must be limited such that the total coincident peak for the system does not exceed 350 MW.

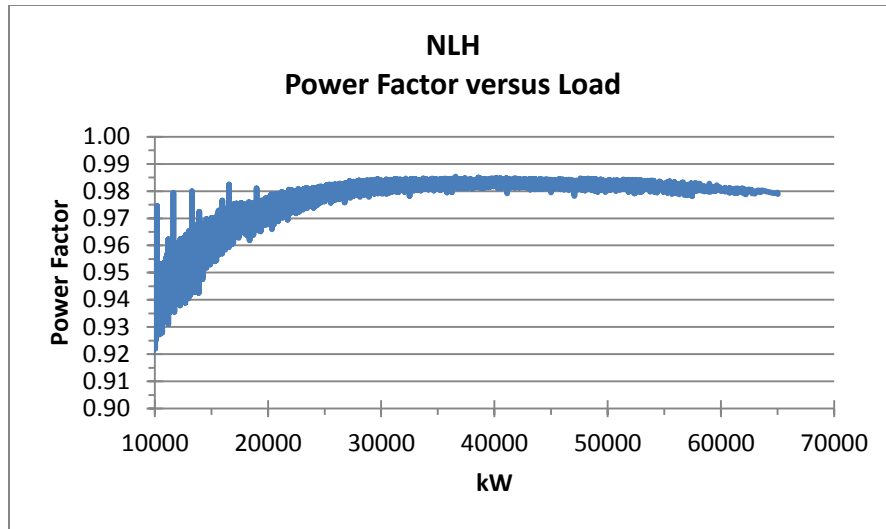

Figure 2: Hydro Power Factor versus Load

1 Historical Wabush Mines 46 kV feeder power factors indicate that the average power factor  
2 over peak is on the order of 0.965, whilst historical IOC power factors are close to 0.95. It is  
3 assumed that the new data centres will have a power factor approaching 0.975.

4

#### 5 **4 Interconnection Alternatives**

6 Transmission system analysis to meet the range of forecasted customer loads involved a series  
7 of load flow and short circuit analyses. Technically viable alternatives were developed and cost  
8 estimates were prepared. Cumulative present worth analysis were then completed in  
9 consideration of life cycle costs.

10

11 The alternatives are categorized as follows:

12 1) Baseline Load Forecast (383 MW): These alternatives are designed to meet all  
13 forecasted baseline loads for customers including Hydro Rural, IOC and Tacora without  
14 load restriction, as summarized in Section 3.

15 2) Low Incremental Load up to 434 MW: These alternatives designed to meet the  
16 unrestricted baseline forecast plus an incremental load of 51.5 MW for data centres, as  
17 summarized in Section 3.

1 3) High Incremental Load >434 MW: These alternatives designed to meet the unrestricted  
2 baseline forecast plus an incremental load associated with data centres and Alderon, as  
3 summarized in Section 3.

4  
5 Seventeen transmission alternatives are considered to supply baseline and incremental load  
6 requirements. Load flow analysis and class 5 cost estimates are detailed in Appendix A. Single-  
7 line diagrams are provided in Appendix B.

- 8 ● Alternative 1: Status Quo (Baseline Forecast without Tacora);<sup>10</sup>
- 9 ● Alternative 2: Status Quo with Curtailment (Baseline Forecast);
- 10 ● Alternative 3: Status Quo with Curtailment (Low Incremental Forecast);
- 11 ● Alternative 4: WTS Upgrades (Baseline Forecast);
- 12 ● Alternative 5: WTS Upgrades (Low Incremental Forecast);
- 13 ● Alternative 6: <sup>11</sup>New 230 kV Transmission Line from Churchill Falls to Wabush Terminal  
14 Station;
- 15 ● Alternative 7: New 230 kV Transmission Line from Churchill Falls to Flora Lake;
- 16 ● Alternative 8: New 315 kV Transmission Line from Bloom Lake to Flora Lake;
- 17 ● Alternative 9: New 315 kV Transmission Line from Bloom Lake to Flora Lake with 46 kV  
18 Connection from Flora Lake;
- 19 ● Alternative 10: 315 kV Interconnection from Churchill Falls to Flora Lake with 46 kV  
20 Connection from Flora Lake;
- 21 ● Alternative 11: 315 kV Interconnection from Churchill Falls and Bloom Lake to Flora Lake  
22 with 46 kV Connection from Flora Lake;
- 23 ● Alternative 12: 200 kV VSC HVdc Monopole Transmission Line from Bloom Lake to Flora  
24 Lake with 46 kV Connection from Flora Lake;
- 25 ● Alternative 13: HVdc VSC Back-to-Back Converter at BLK – 230 kV Transmission Line  
26 from Bloom Lake to Flora Lake with 46 kV Connection from Flora Lake;

---

<sup>10</sup>In the event that Tacora operations do not materialize, the baseline load forecast would be reduced and would not exceed the 350 MW capacity of the existing transmission system. An assessment of this condition is presented in Appendix A.

<sup>11</sup>Alternatives 6 through 17 can provide adequate capacity for all load forecast scenarios.

- 1       ● Alternative 14: HVdc VSC Back-to-Back Converter at Bloom Lake – 230 kV Transmission
- 2       Line from Bloom Lake to Wabush
- 3       ● Alternative 15: 200 MW of Gas Turbines at Wabush Terminal Station;
- 4       ● Alternative 16: New 230 kV Transmission Line from Churchill Falls to Flora Lake; and
- 5       ● Alternative 17: New 315 kV Transmission Line from Bloom Lake to Flora Lake with 46 kV
- 6       Connection from Flora Lake.

7

## 8   **5 Lifecycle Cost Analysis**

9   An analysis was performed for the 17 alternatives described in the previous section.

10   Consideration was given to capital costs, as provided in Appendix A of this document, as well as  
11   to transmission system loss impacts and operating and maintenance costs. This section  
12   provides an overview of these considerations as well the results of the cost-benefit analysis for  
13   each forecast category.

14

### 15   **5.1 Transmission System Losses Impact**

16   The construction of a new transmission interconnection will reduce system losses. For the  
17   purposes of this investigation, revenue associated with exports is approximated at \$35 per  
18   MWh. An overall reduction in losses would therefore provide incremental revenue.

19

#### 20   **5.1.1 Transmission System Losses Churchill Falls to Labrador West**

21   A transmission system loss evaluation has been completed to assess the value of transmission  
22   system losses for the period from 2022 to 2043 for both continued supply of western Labrador  
23   via Churchill Falls using existing 230 kV transmission lines L23 and L24<sup>12</sup> and for cases involving  
24   a new interconnection. Annual loss revenues for the low and high incremental load scenarios  
25   are provided in Appendix C of this document.

---

<sup>12</sup>For the purposes of loss analysis, Alternative 5 is used as a representative case for the continued supply using existing 230 kV transmission lines L23 and L24 for low and high incremental load scenarios.



1 **5.2 Operation and Maintenance Cost Assumptions**

2 For the purpose of this study, the operating and maintenance (“O&M”) costs were calculated  
3 using the *April 2018 Transmission O&M Cost Benchmark Study*, prepared by Christensen  
4 Associates Energy. These values are summarized in Table 3 with detailed information provided  
5 in Appendix D.

**Table 3: Fixed O&M Benchmark Template**

Category	Fixed O&M Costs	Comments
230 kV AC Transmission Line	\$4,611/km	
315 kV AC Transmission Line	\$5,489/km	Common Route Factor of 0.6 applied if on common ROW <sup>13</sup>
315 kV Terminal Station Facilities	\$4,060/MW	Based on Surge Impedance Loading of Line (328 MW for 315 kV)
DC Transmission Line	\$5,003/km	
DC Converter Facilities	\$13,228/MW	

6 **5.3 Cost Benefit Analysis**

7 A cost benefit analysis has been completed for all baseline and sensitivity forecast alternatives.  
8 Table 4 outlines the Cumulative Present Worth (“CPW”) of all alternatives.

---

<sup>13</sup> Right of Way (“ROW”).

**Table 4: Overview of CPW of Alternatives and Transfer Capacity**

Alt.	Description	Forecast (MW)	Winter Firm Capacity (MW)	Non-Firm Capacity (MW)	Estimated Cost (\$ million)	CPW (\$ million)
1	Status Quo (without Tacora)	<350	252	350	1.43	1.21
2	Status Quo with Curtailment (Baseline)	383	252	350	1.82	11.62
3	Status Quo with Curtailment (Low Incremental)	434	252	350	1.82	51.42
4	WTS Upgrades (Baseline)	383	252	387	15.12	13.22
5	WTS Upgrades (Low Incremental)	434	252	454	31.66	27.60
6	230 kV Line from CF <sup>14</sup> to Wabush	434	434	527	251.24	202.53
7	230 kV Line from CF to FLK (230/46 kV)	434	434	528	272.82	221.21
8	315 kV Line from BLK to FLK (315/230 kV)	434	434	514	141.40	151.67
9	315 kV Line from BLK to FLK (315/230/46 kV)	434	434	502	146.99	154.56
10	315 kV Line from CF to FLK (315/230/46 kV)	434	434	574	335.86	282.34
11	315 kV Line from CF and BLK to FLK (315/230/46kV)	434	473	563	397.97	373.53
12	250 MW Monopole from BLK to FLK	434	453	585	347.90	326.58
13	250 MW BtB Converter at BLK – 230 kV Line from BLK to FLK	434	434	612	233.16	205.03
14	250 MW BtB Converter at BLK – 230 kV Line from BLK to WTS	434	434	603	216.70	190.93
15	200 MW Gas Turbine	434	482	573	589.20	634.50
16	230 kV Line to FLK (230/46 kV)	499	499	636	279.72	214.78
17	315 kV Line from BLK to FLK	499	499	600	153.15	148.09

<sup>14</sup> Churchill Falls (“CF”).

1 **6 Conclusions and Recommendations**

2 The existing 230 kV transmission system has a non-firm winter capacity of 350 MW and is  
3 adequate only if supply to industrial customers is restricted. Transmission system upgrades are  
4 required to meet the baseline peak load forecast, which is expected to reach 383 MW by 2043.

5

6 Table 5 includes a summary of the preferred solutions to meet the baseline forecast as well as  
7 low and high incremental sensitivity forecasts.

**Table 5: Overview of CPW of Preferred Alternatives and Transfer Capacity**

Alt	Description	Forecast (MW)	Winter Firm Capacity (MW)	Non-Firm Capacity (MW)	Estimated Cost (\$ million)	CPW (\$ million)
4	WTS Upgrades (Baseline)	383	252	387	15.1	13.2
5	WTS Upgrades (Low Incremental)	434	252	454	31.7	27.6
17	315 kV Transmission Line from BLK to FLK with 46 kV connection from FLK	499	499	600	153.2	148.1

8 Recommended transmission system expansions are summarized as follows:

- 9
- Labrador West Baseline load forecast - 383 MW:
    - reconductoring of 46 kV transmission lines for rural customers to avoid overload conditions;
    - commissioning of SC3 and 30 MVAR reactor;
    - replacement of transformers T4 and T5 with 125 MVA units;
    - replacement of four, 46 kV circuit breakers due to exceeding fault level;
    - installation of 23 MVARs of capacitors on 46 kV bus (needed for loss of SC3);
- 10  
11  
12  
13  
14  
15

- 1           ○ system study for capacitor bank addition with possible future addition of another 49
- 2           MVARs on the 46 kV bus; and
- 3           ○ terminal station condition assessment.
- 4           ● Labrador West load exceeds 383 MW, up to 434 MW:
  - 5           ○ commissioning of SC and 30 MVAR reactor;
  - 6           ○ replacement of T4, T5, and T6 with 125 MVA units for loss of largest transformer;
  - 7           ○ replacement of four, 46 kV circuit breakers due to exceeding fault level;
  - 8           ○ installation of 72 MVARs of reactive compensation (needed for loss of SC3);
  - 9           ○ thermal upgrade of L23/L24 to 75°C conductor temperature;
  - 10          ○ system study for capacitor bank addition with possible future addition of another 49
  - 11          MVARs on the 46 kV bus; and
  - 12          ○ terminal station condition assessment.
- 13          ● Labrador West load exceeds 434 MW:
  - 14          ○ construction of 50 km of 315 kV transmission line from BLK Station to FLK Station
  - 15          and 5 km of 230 kV transmission line from FLK Station to WTS;
  - 16          ○ new 315/230/46 kV terminal station at FLK complete with 73 MVAR caps;
  - 17          ○ commissioning of SC3;
  - 18          ○ replacement of T4, T5, and T6 with 125 MVA units for loss of largest transformer;
  - 19          ○ replacement of 15, 46 kV circuit breakers due to exceeding fault level;
  - 20          ○ new 230 kV line termination at Wabush Terminal Station; and
  - 21          ○ 315 kV Line termination at BLK.

## **Appendix A**

### **Labrador West Future Transmission Supply Alternatives**

1 A total of 17 transmission alternatives are considered to supply the future load requirements of  
2 the Labrador West Transmission System. This section includes an overview of the alternatives  
3 as well as the load flow analysis that was performed for each. The analysis was completed using  
4 the Siemens Power Technologies Int. software package PSS®E version 33. Capital costs for each  
5 alternative are provided and were developed on the basis of the single-line diagrams presented  
6 in Appendix B of this document.

7

### 8 **Alternative 1: Status Quo – Baseline without Tacora**

9 This scenario represents the lightest forecasted load condition where Tacora operations at the  
10 Wabush Mines do not materialize as per the baseline forecast and loads do not exceed 350  
11 MW. In this case no transmission system additions are required other than 46 kV line upgrades  
12 for the reliable supply to Hydro Rural load. The estimated capital cost is \$1.4 million.<sup>15</sup> The  
13 existing transmission system in Labrador West has a capacity of 350 MW as outlined in Figure  
14 A1. The transfer limit is due to voltage constraints for synchronous condensers SC1 and SC2.

---

<sup>15</sup> As per *Labrador West 46 kV System Expansion – Existing 46 kV System and Future Alternatives*, TP-R-024, Hydro, October, 2018

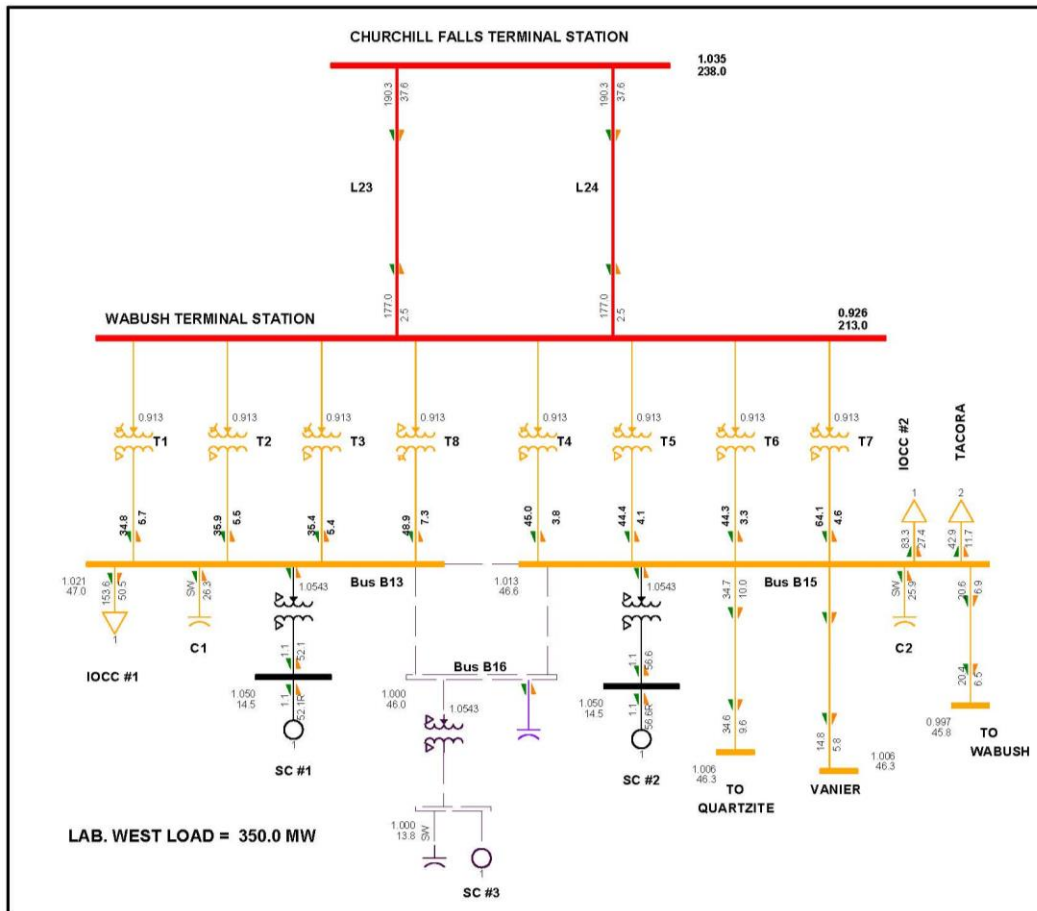

Figure A1: Alternative 1 – Existing Maximum Labrador West Load Capability with No Outages

1 **Alternative 2: Status Quo with Curtailment (Baseline Forecast)**

2 This alternative has the same transmission system capacity as Alternative 1, but curtailment is  
 3 required as loads are forecasted to reach 383 MW and are in excess of the system capacity of  
 4 350 MW. Such an approach is not acceptable as the basis of the analysis is to ensure adequate  
 5 supply without customer interruption with all equipment in service. Consideration was given to  
 6 this case to assess the cost of load interruption for the purposes of comparison.

1 It is assumed that the curtailment agreement would be establish with industrial customers at a  
2 rate of \$10/kW per month such that any load in excess of 350 MW will be curtailed. The  
3 estimated capital cost is \$1.8 million.<sup>16</sup>  
4

### 5 **Alternative 3: Status Quo Status Quo with Curtailment (Low Incremental** 6 **Forecast)**

7 This alternative is the same as Alternative 2, but with low incremental load forecast loads in  
8 service where curtailment is required for loads above 350 MW. The estimated capital cost is  
9 \$1.8 million. In this case, the expected 2043 peak load would be approximately 434 MW. Like  
10 Alternative 2, this is not a viable technical alternative, but is presented as a basis of comparison  
11 for lifecycle costs.  
12

### 13 **Alternative 4: Wabush Terminal Station Upgrades (Baseline Forecast)**

14 This alternative involves transmission system upgrades to provide firm capacity of 383 MW to  
15 the WTS for all contingencies with the exception of loss of either L23 or L24.  
16

17 Alternative 4 includes commissioning of the third synchronous condenser at Wabush,  
18 installation of an additional 23 MVAR of shunt compensation on the 46 kV bus B16 and  
19 replacement of transformers T4 and T5 with 125 MVA units and 46 kV upgrades. These  
20 upgrades will allow system load to reach 383 MW which reflects the low incremental load  
21 scenario. The estimated capital cost is \$15.12 million.  
22

23 Analysis was performed to ensure that there would be no overloads for the loss of the largest  
24 transformer at WTS. For peak load case of 383 MW and loss of 83 MVA transformer T7

---

<sup>16</sup> As per *Labrador West 46 kV System Expansion – Existing 46 kV System and Future Alternatives, TP-R-024*, Hydro, October, 2018



- 1 transformers T4, T5, and T6 are overloaded as can be seen from Figure A2.<sup>17</sup> The installation of
- 2 a 125 MVA power transformer is therefore required.

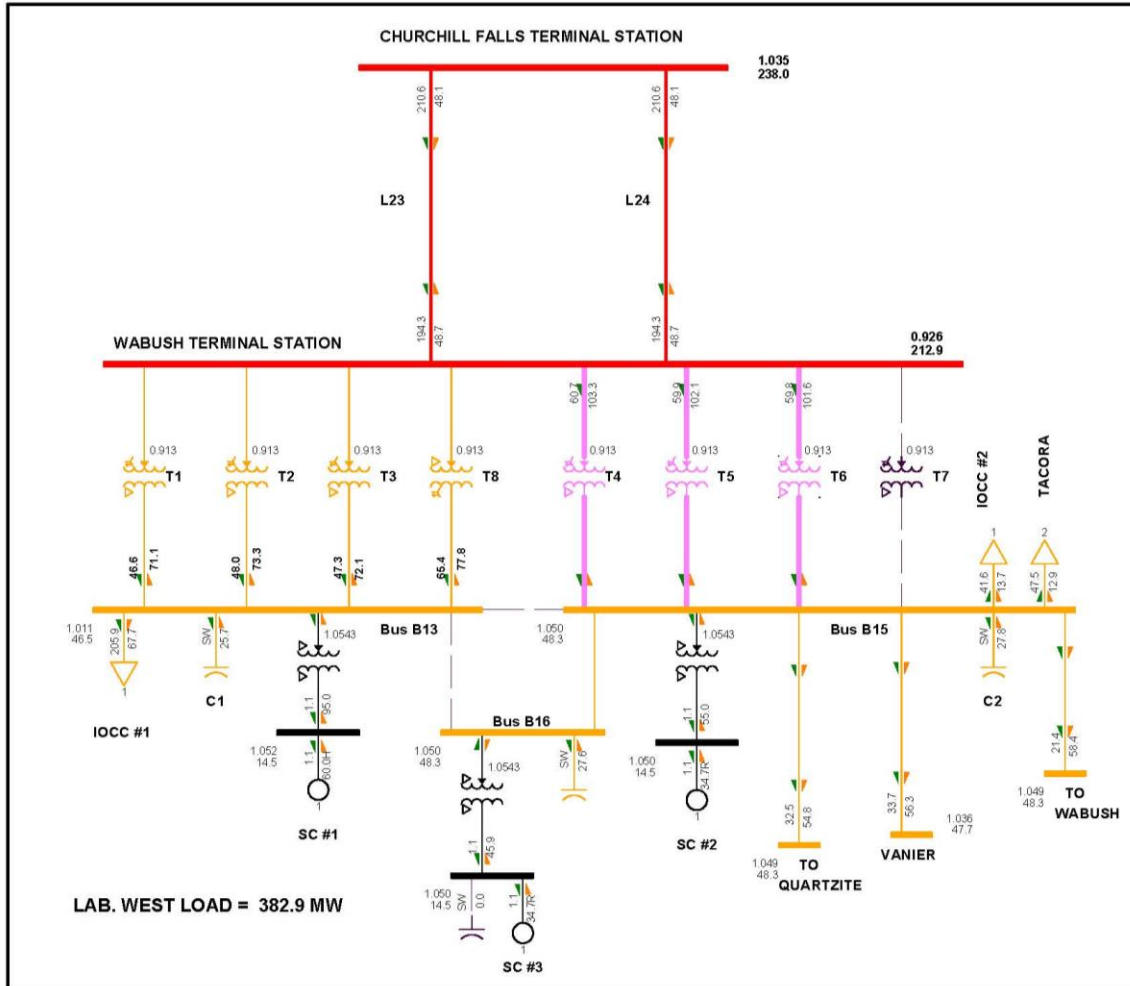
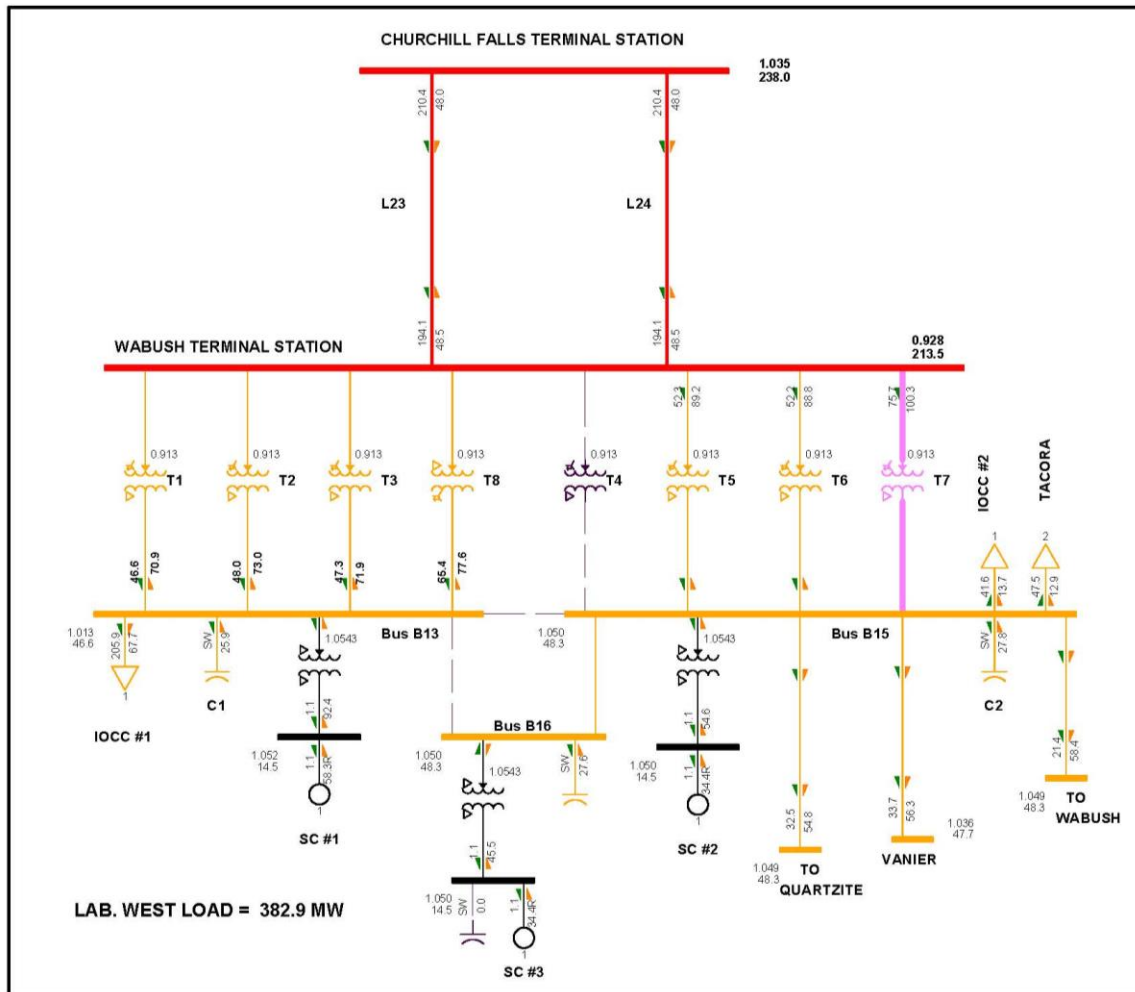

**Figure A2: Alternative 4 – 2043 Peak Load Loss of T7**

- 3 With T4 upgraded to 125 MVA, it becomes the largest transformer at WTS. An outage to this
- 4 unit would therefore reduce capacity Bus B15 to the sum of transformers T5 (65 MVA), T6 (65
- 5 MVA), and T7 (83 MVA).

<sup>17</sup> This scenario involves the transfer of approximately 50 MW of load on feeder 5A to Bus B13 from Bus 15.

- 1 Figure A3 shows that with loss of transformer T4 transformer, T7 is overloaded. It is therefore a
- 2 requirement to upgrade at least two transformers to 125 MVA.



**Figure A3: Alternative 4 – 2043 Peak Load Loss of T4**

- 3 Figure A4 includes a scenario involving the loss of synchronous condenser SC3 with an
- 4 additional 23 MVAR shunt compensation added to the 46 kV bus. The peak load of 383 MW can
- 5 be supplied in this case. With all equipment in service, a peak load of 421 MW can be supplied.

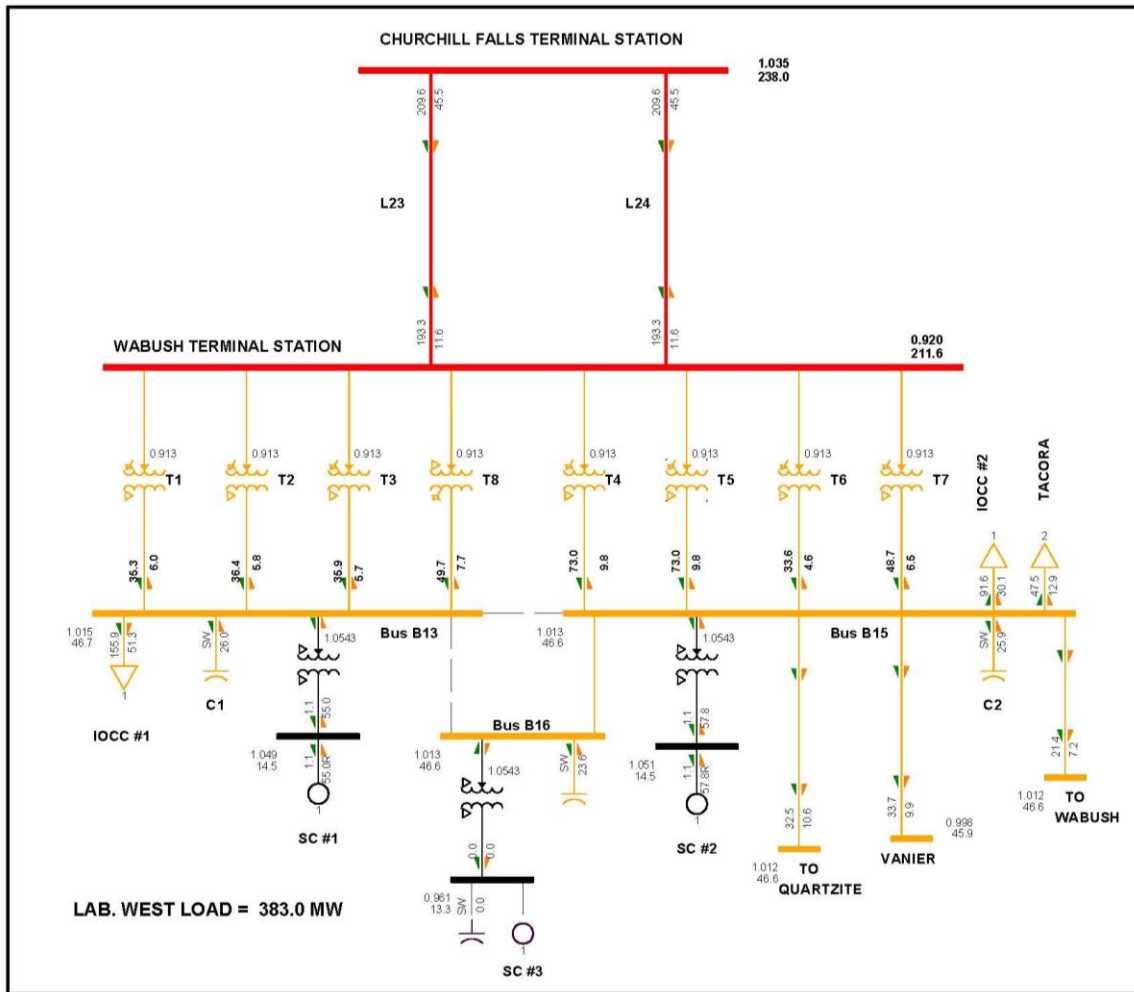

Figure A4: Alternative 4 – 2043 Peak Load Loss of SC3

- 1 Figure A5 outlines the loading experienced on L23 and L24 during the summer peak, with these
- 2 lines being rated for 175 MVA for a 30°C ambient temperature day. The transmission lines are
- 3 loaded at approximately 93 percent of their thermal rating in this case.

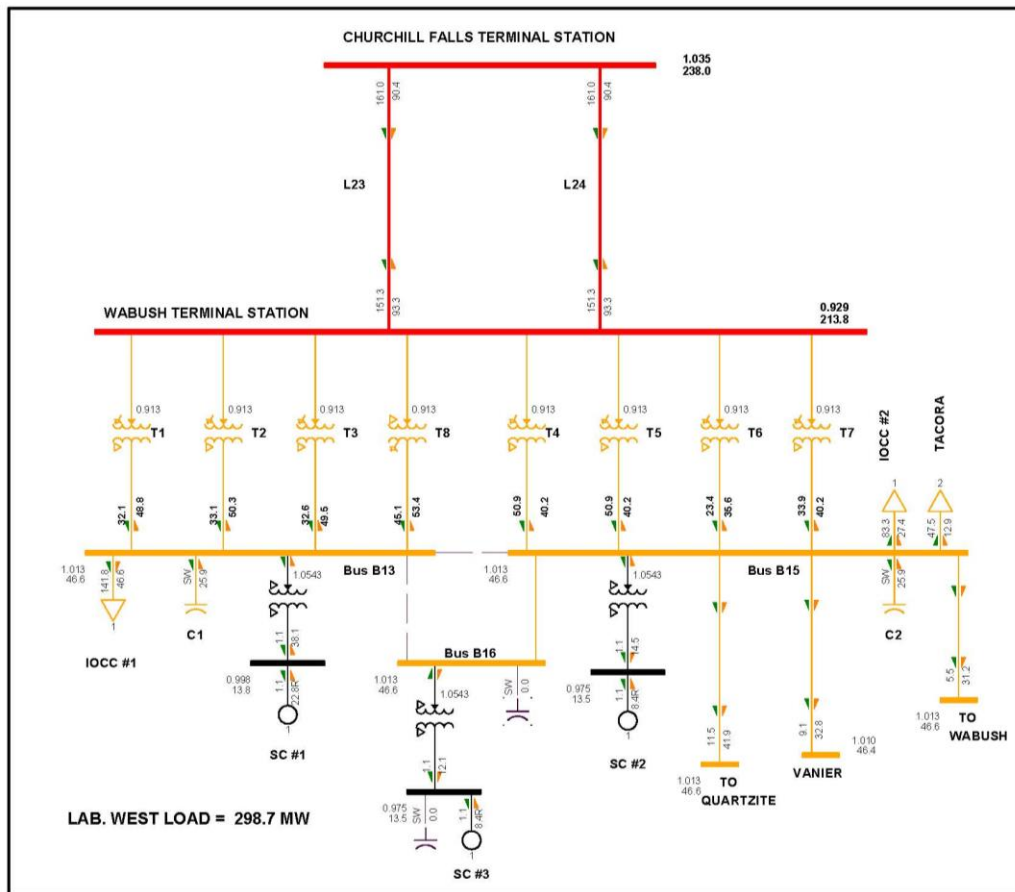

Figure A5: Alternative 4 – 2022 Peak Summer Load with No Outages

- 1 Costs associated with this alternative are summarized in Table A1.

Table A1: Summary of Costs for Alternative 4

Capital Work Required	Class 5 Estimate (\$ million)
Fully commission synchronous condenser SC3	0.50
Replace 65 MVA transformers T4 and T5 with 125 MVA units, complete with OLTC <sup>18</sup>	10.42
Installation of one, 23 MVAR capacitor banks on 46 kV Bus B16	1.61
Upgrade of four, 46 kV breakers with 2000 A, 31.5 kA breakers	0.77
46 kV upgrades to distribution lines	1.82
<b>Total</b>	<b>15.12</b>

<sup>18</sup> On-load tap changer (“OLTC”).

1 **Alternative 5: Wabush Terminal Station Upgrades (Low Incremental Load)**

2 This alternative involves transmission system upgrades to provide firm capacity of 434 MW to  
3 the WTS for all contingencies with the exception of loss of either L23 or L24. These include the  
4 commissioning of the third synchronous condenser at Wabush, installation of an additional 72  
5 MVAR of shunt compensation on the 46 kV bus B16, the replacement of transformers T4, T5,  
6 and T6 with 125 MVA units and thermal upgrade of L23 and L24 to a 75°C conductor  
7 temperature. 46 kV lines are also required to prevent thermal overloading. The estimated  
8 capital cost is \$31.66 million.

9

10 For this alternative, transformer selection was chosen to eliminate overloading due to loss of  
11 the largest transformer, under the assumption that transformers T4 and T5 were replaced with  
12 125 MVA transformers. For peak load case of 434 MW and loss of 125 MVA transformer T5,  
13 transformers T4 and T7 are loaded to capacity. To avoid a transformer overload condition, a  
14 replacement is required for T6.

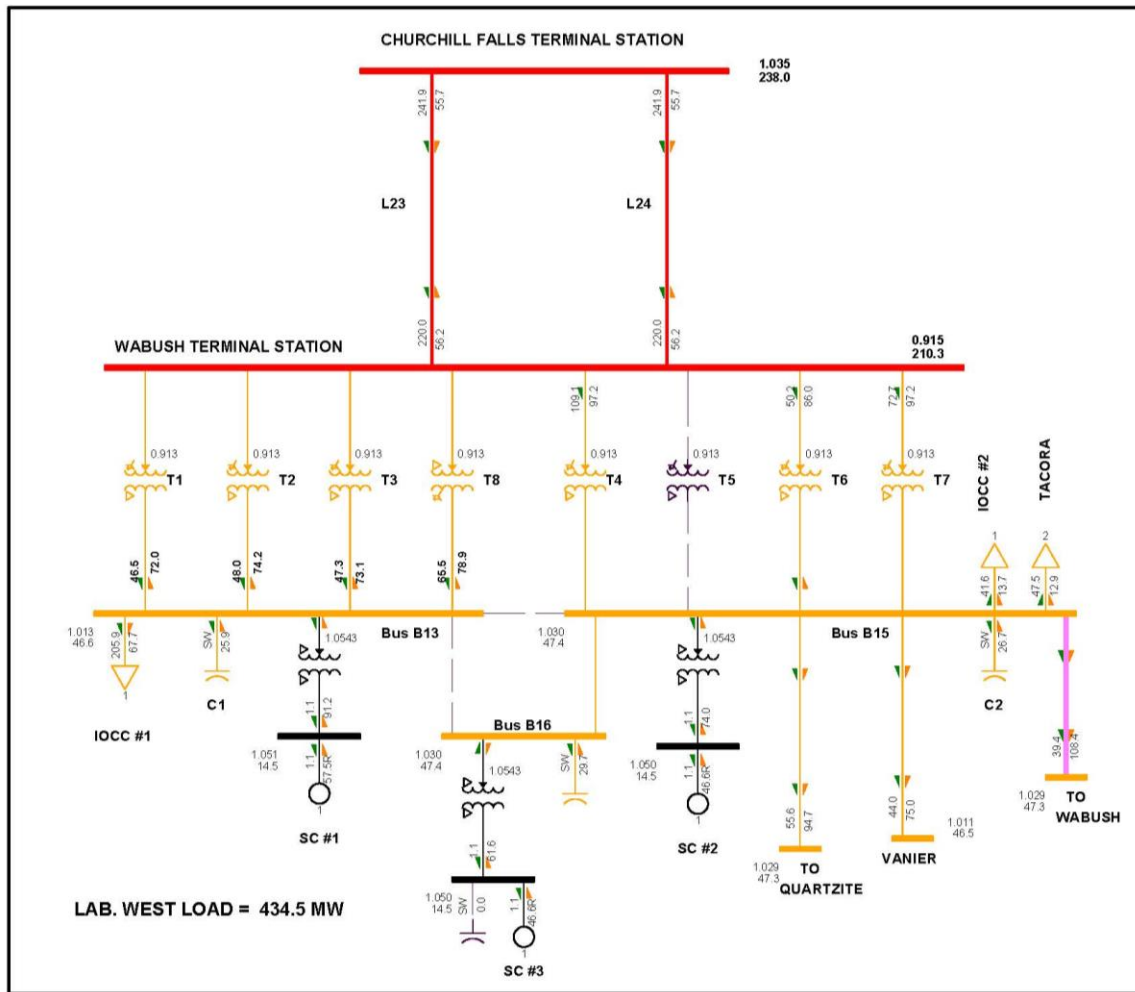
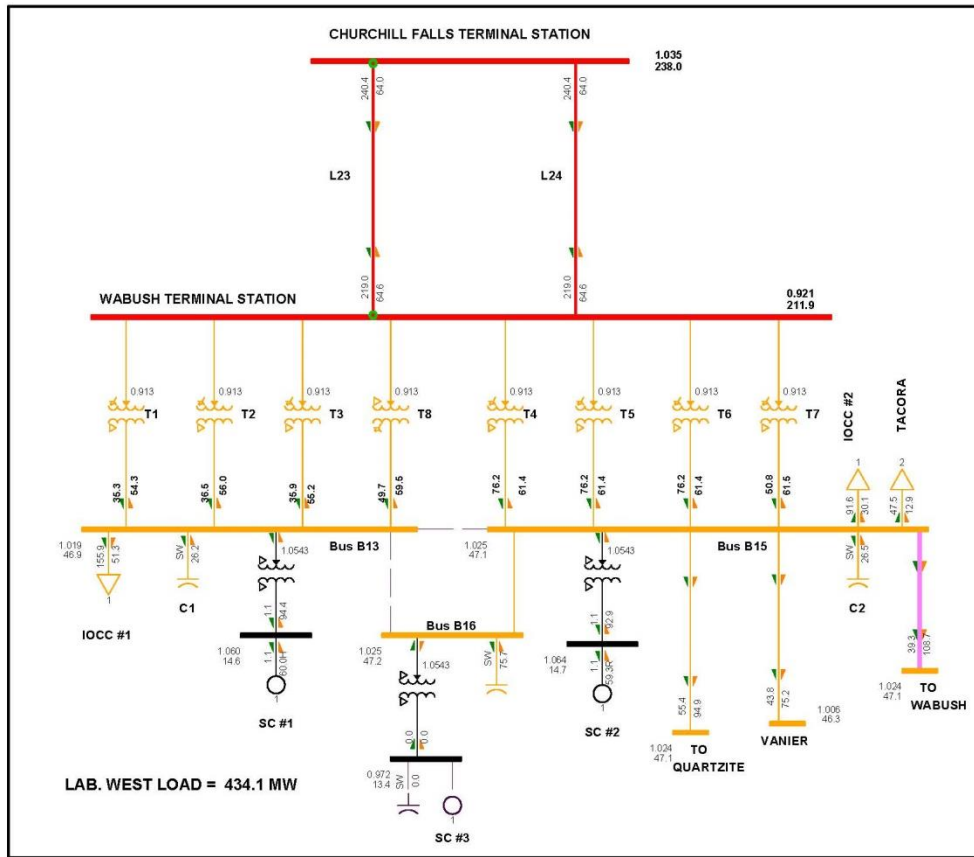

Figure A6: Alternative 5 – 2043 Peak Load Loss of T5

- 1 Figure A7 outlines the scenario involving the loss of the third synchronous condenser with an
- 2 additional 72 MVAR shunt compensation added to the 46 kV bus. The peak load of 434 MW is
- 3 able to be met under this contingency. The restriction under this contingency is that SC1 and
- 4 SC2 are at their maximum reactive power output.
- 5
- 6 With all equipment in service, a peak load of 454 MW can be supplied.



**Figure A7: Alternative 5 – 2043 Peak Load Loss of SC3**

- 1 Figure A8 outlines the loading experienced on L23 and L24 during the summer peak, with these
- 2 lines being rated for 175 MVA for a 30°C ambient temperature day. This load flow shows that
- 3 the lines are at approximately 109 percent of their thermal rating. Thermal uprating is
- 4 therefore required.

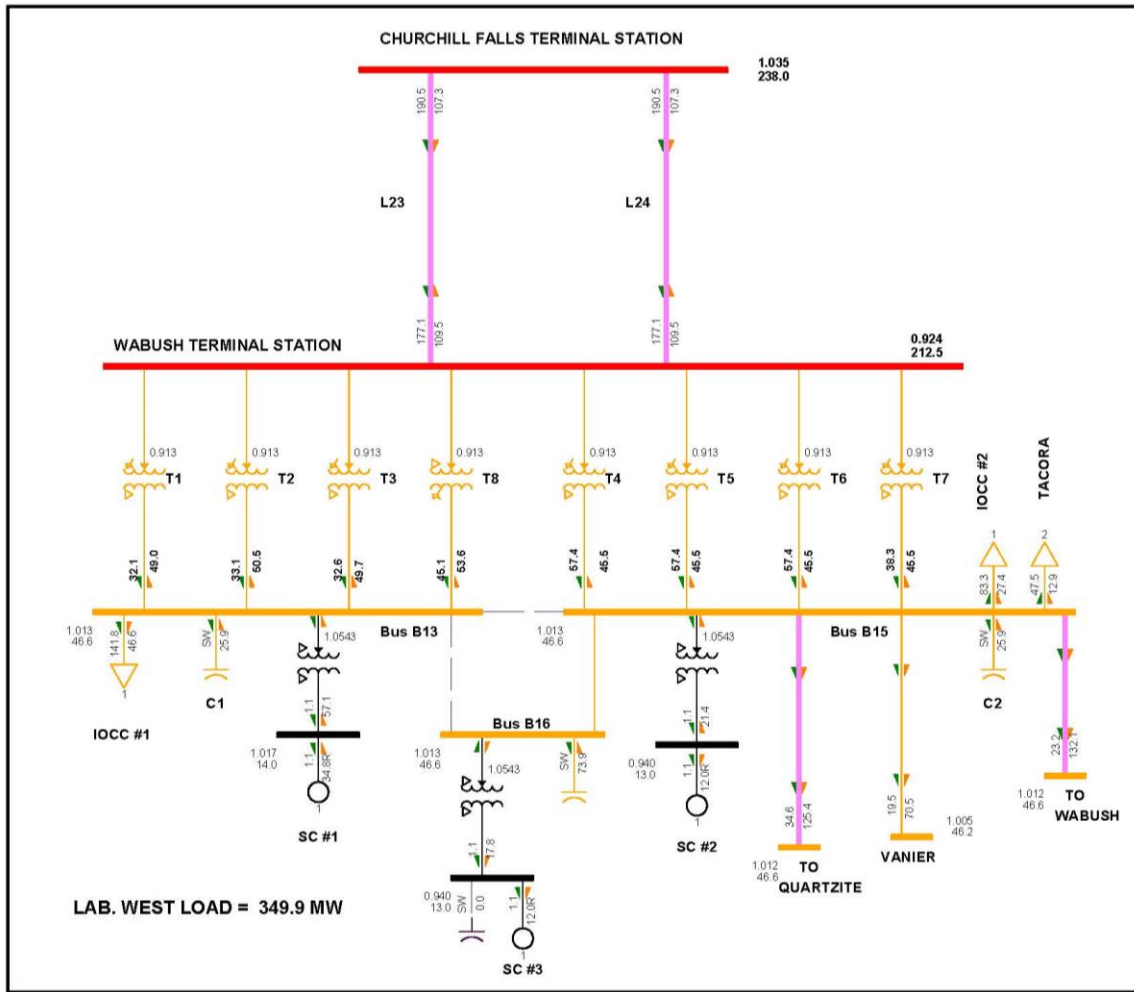

Figure A8: Alternative 5 – 2022 Peak Summer Load with No Outages

- Costs associated with this alternative are summarized in Table A2.

Table A2: Summary of Costs for Alternative 5

Capital Work Required	Class 5 Estimate (\$ million)
Fully commission synchronous condenser SC3	0.50
Replace 65 MVA transformers T3, T4, T5, and T6 with 125 MVA units, complete with OLTC.	15.63
Installation of three, 24 MVAR capacitor banks on 46 kV Bus B16	5.04
Upgrade of four, 46 kV breakers with 2000 A, 31.5 kA breakers	0.77
46 kV upgrades to distribution lines	1.82
Thermal Upgrade of L23 and L24 to 75°C conductor temperature	7.90
<b>Total</b>	<b>31.66</b>



1 **Alternative 6: New 230 kV Transmission Line from Churchill Falls to Wabush**

2 **Terminal Station**

3 This alternative calls for the interconnection of a new 215 km, 230 kV transmission line from  
4 Churchill Falls to WTS.<sup>19</sup> Other major upgrades would include replacement of transformers T4,  
5 T5 and T6, commissioning of SC3 and additional 19 MVAR of capacitor banks. 46 kV line  
6 upgrades are also required to avoid overload conditions. These upgrades provide a firm  
7 capacity of 434 MW to Labrador West for all contingencies. The estimated capital cost is  
8 \$251.24 million.

9  
10 Figure A9 outlines the single worst contingency, loss of the new 230 kV transmission line from  
11 Churchill Falls with an additional 19 MVAR shunt compensation added to the 46 kV bus. The  
12 peak load of 434 MW is able to be met under this contingency. The restriction under this  
13 contingency is that SC1, SC2, and SC3 are at their maximum reactive power output.

14  
15 With all equipment in service, a peak load of approximately 527 MW can be met.

---

<sup>19</sup> Details of voltage and conductor selection for alternatives are provided in Appendix E.

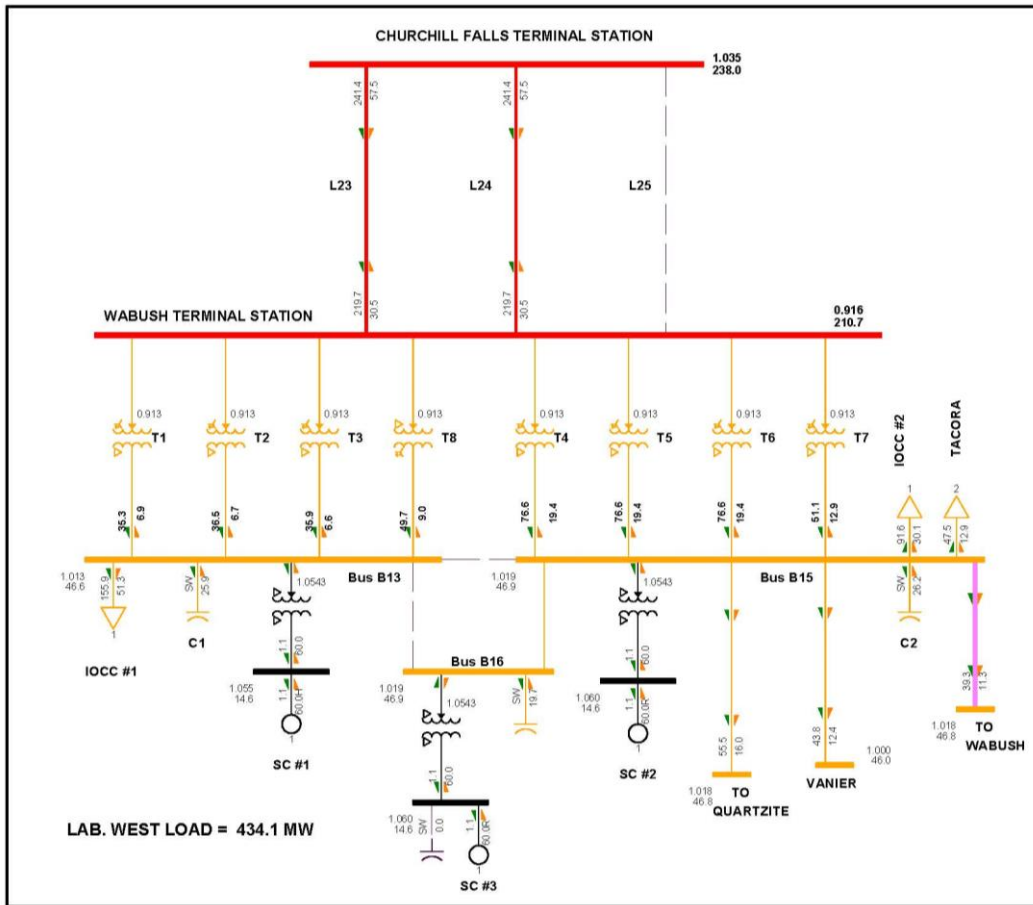

Figure A9: Alternative 6 – 2043 Peak Load Loss of New 230 kV Line L25

- 1 Costs associated with this alternative are summarized in Table A3.

Table A3: Summary of Costs for Alternative 6

Capital Work Required	Class 5 Estimate (\$ million)
Construction of 215 km of 230 kV line from CF to WTS	224.11
CF 230 kV Line Termination	1.89
WTS 230 kV Line Termination	1.66
Fully commission synchronous condenser SC3	0.50
Replace 65 MVA transformers T4, T5, and T6 with 125 MVA units, complete with OLTC.	15.63
Installation of one, 19 MVAR capacitor bank on 46 kV Bus B16	1.33
Upgrade of 15, 46 kV breakers with 2000 A, 31.5 kA breakers	4.28
46 kV upgrades to distribution lines	1.82
<b>Total</b>	<b>251.24</b>

1 The 230 kV transmission line from Churchill Falls to Wabush would have an assumed Grackle  
2 1192.5 kcmil conductor with operating temperature of 75°C, complete with optical ground wire  
3 (“OPGW”).  
4

#### 5 **Alternative 7: New 230 kV Transmission Line from Churchill Falls to Flora Lake**

6 Alternative 7 includes the construction of 210 km of overhead 230 kV transmission line from  
7 Churchill Falls to a new 230/46 kV terminal station at FLK, new 5 km overhead 230 kV line from  
8 FLK to Wabush, commissioning of the third synchronous condenser at Wabush and installation  
9 of 29 MVAR of shunt compensation on the 230 kV at FLK. Also required would be the addition  
10 of 25 km of new 46 kV lines plus 46 kV line upgrades to avoid overload conditions. This will  
11 provide a firm capacity of 434 MW to Labrador West for all contingencies. The estimated  
12 capital cost is \$272.82 million.  
13

14 Figure A10 outlines a scenario involving the loss of the new 230 kV transmission line from  
15 Churchill Falls to FLK with an additional 29 MVAR shunt compensation added to the 230 kV bus  
16 at FLK. The peak load of 434 MW is able to be met under this contingency. The restriction under  
17 this contingency is that SC1, SC2, and SC3 are at their maximum reactive power output.  
18

19 With all equipment in service, a peak load of approximately 528 MW can be met.

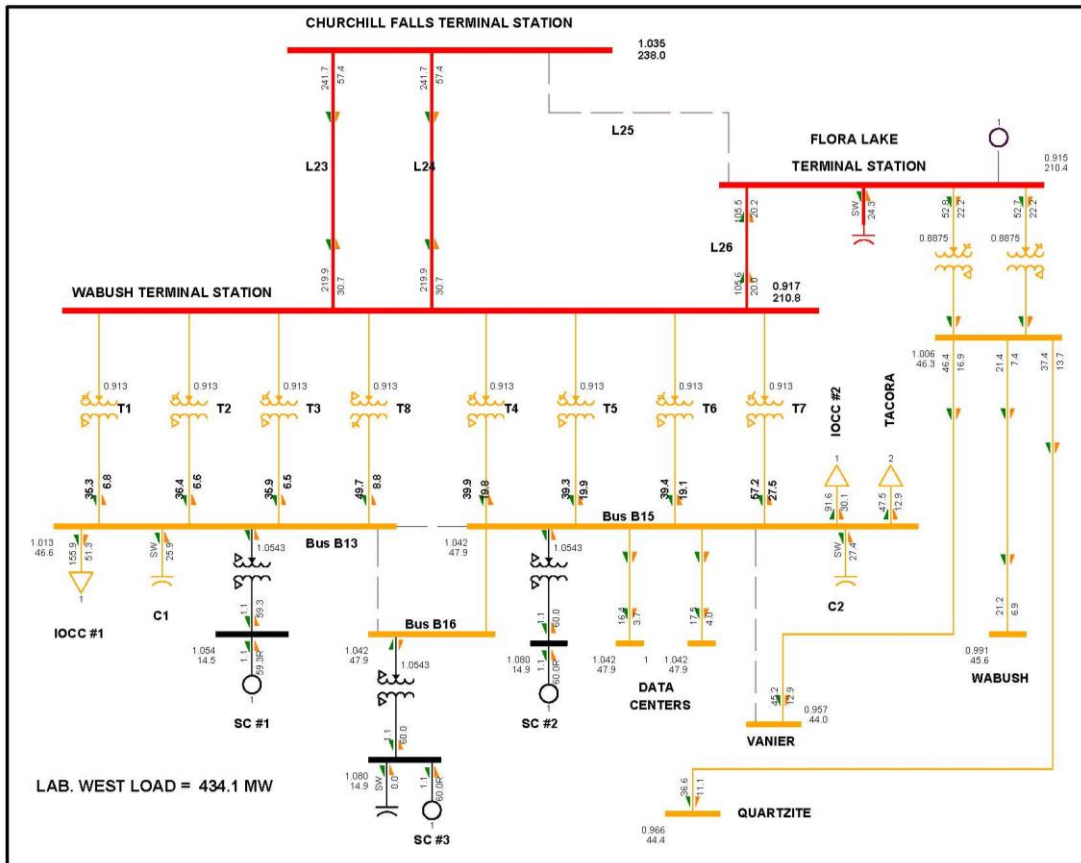

Figure A10: Alternative 7 – 2043 Peak Load Loss of New 230 kV Line L25

1 Costs associated with this alternative are summarized in Table A4.

Table A4: Summary of Costs for Alternative 7

Capital Work Required	Class 5 Estimate (\$ million)
Construction of 210 km of 230 kV line from CF to FLK and 5 km of 230 kV line from FLK to WTS	228.38
CF 230 kV Line Termination	1.89
WTS 230 kV Line Termination	1.66
Construction of new 230/46 kV terminal station at FLK	27.90
Installation of one, 29 MVAR capacitor bank on FLK 230 kV Bus	2.03
Fully commission synchronous condenser SC#3	0.50
Upgrade of 10, 46 kV breakers with 2000 A, 31.5 kA breakers	2.85
25 km of new 46 kV lines plus upgrades to existing distribution lines	7.72
<b>Total</b>	<b>272.82</b>

1 The 230 kV transmission line from Churchill Falls to FLK to Wabush would have an assumed  
2 Grackle 1192.5 kcmil conductor with operating temperature of 75°C complete with OPGW. The  
3 new 230/46 kV terminal station at FLK terminal station would consist of two breaker and a third  
4 diameters, two new 230/46 kV, 125 MVA transformers complete with OLTCs and 29 MVAR, 230  
5 kV capacitor bank.

6

### 7 **Alternative 8: New 315 kV Transmission Line from Bloom Lake to Flora Lake**

8 Alternative 8 includes the construction of 50 km<sup>20</sup> of overhead 315 kV transmission line from  
9 BLK to a new 315/230 kV terminal station at FLK, a new 5 km overhead 230 kV line from FLK to  
10 Wabush and installation of 73 MVAR of shunt compensation on the 230 kV bus at FLK. At WTS,  
11 commissioning of the third synchronous condenser and replacement of transformers T4, T5,  
12 and T6 with 125 MVA units are required. This will provide a firm capacity of 434 MW to  
13 Labrador West for all contingencies. The estimated capital cost is \$141.40 million.

14

15 Figure A11 outlines a scenario involving the loss of 230 kV line L24 from Churchill Falls to  
16 Wabush. This case requires 73 MVAR shunt compensation added to the 230 kV bus at FLK. The  
17 peak load of 434 MW is able to be met under this contingency. The restriction under this  
18 contingency is that SC1, SC2, and SC3 are at their maximum reactive power output.

19

20 With all equipment in service, a peak load of approximately 514 MW can be met.

---

<sup>20</sup> The distance is estimated to be in the range of 26 km to 50 km and would be confirmed during detailed design.

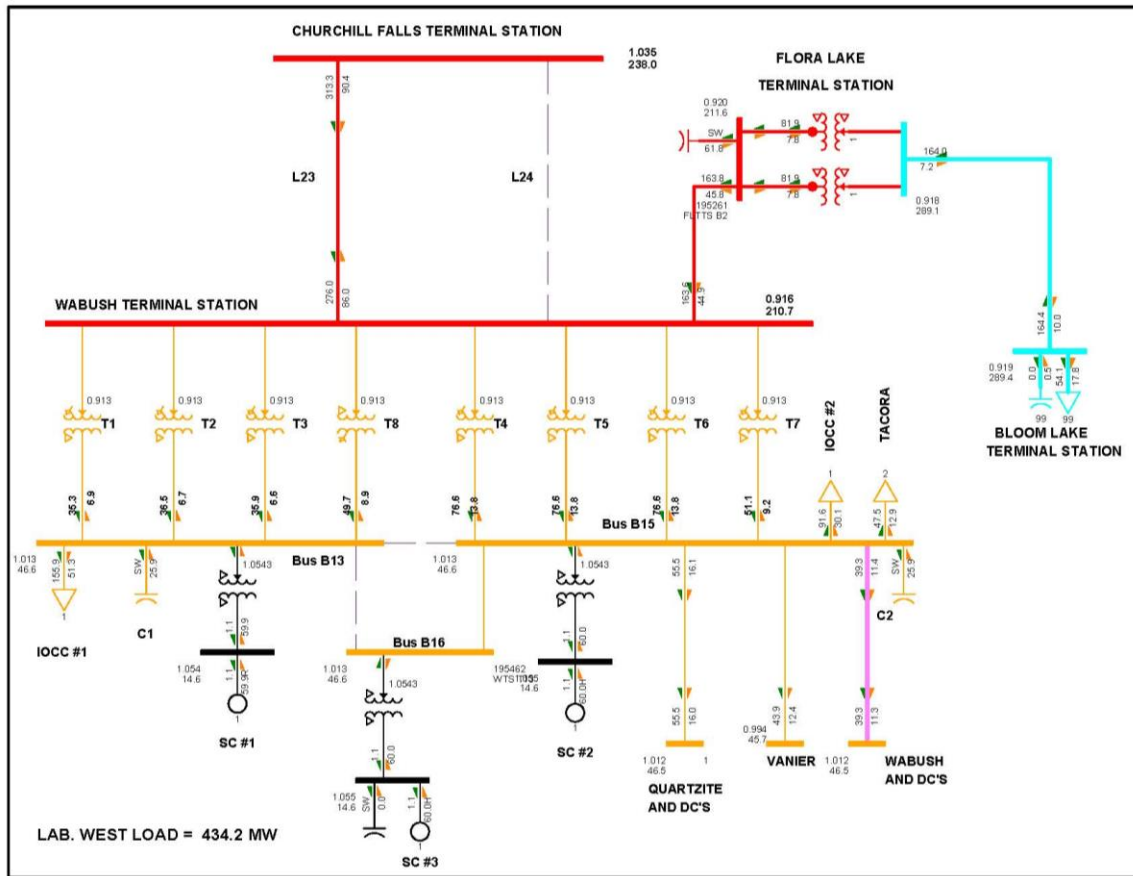

Figure A11: Alternative 8 – 2042 Peak Load Loss of L24

- Costs associated with this alternative are summarized in Table A5.

Table A5: Summary of Costs for Alternative 8

Capital Work Required	Class 5 Estimate (\$ million)
Construction of 50 km of 315 kV transmission line from BLK to FLK and 5 km of 230 kV from FLK to WTS.	74.70
BLK 315 kV Line Termination	2.90
WTS 230 kV Line Termination	1.66
Construction of new 315/230 kV terminal station at FLK	34.80
Installation of three, 24.3 MVAR capacitor banks on FLK 230 kV Bus	5.11
Fully commission synchronous condenser SC3	0.50
Upgrade of 15, 46 kV breakers with 2000 A, 31.5 kA breakers	4.28
Replace 65 MVA transformers T4, T5, and T6 with 125 MVA units, complete with OLTC.	15.63
46 kV upgrades to distribution lines	1.82
<b>Total</b>	<b>141.40</b>

---

1 The 315 kV transmission line is assumed to consist of twin Drake conductor with 75°C  
2 conductor operating temperature complete with OPGW. The 230 kV transmission line from FLK  
3 to WTS is assumed to be Grackle 1192.5 kcmil conductor with operating temperature of 75°C  
4 complete with OPGW. The new 315/230 kV terminal station at FLK terminal station would  
5 consist of two breaker and a half diameters for both the 315 and 230 kV sections. FLK terminal  
6 station to include two new 315/230/13.8 kV, 333 MVA auto-transformers complete with OLTCs  
7 and 73 MVAR, 230 kV capacitor bank.

8

9 **Alternative 9: New 315kV Transmission Line from Bloom Lake to Flora Lake with**  
10 **46 kV Connection from Flora Lake**

11 Alternative 9 includes the construction of 26 to 50 km (TBD) of overhead 315 kV transmission  
12 line from BLK to a new 315/230/46 kV terminal station at FLK, a new 5 km overhead 230 kV line  
13 from FLK to Wabush and installation of 73 MVAR of shunt compensation on the 230 kV bus at  
14 FLK. Commissioning of the third synchronous condenser at WTS and the addition of 25 km of  
15 new 46 kV lines plus 46 kV line thermal upgrades are required to prevent overload condition.  
16 This will provide a firm capacity of 434 MW to Labrador West for all contingencies. The  
17 estimated capital cost is \$146.99 million.

18

19 For Alternative 9, the loss of any single component should not prevent the supply of the 2043  
20 peak load of 434 MW. Figure A12 outlines a scenario involving the loss of 230 kV line L24 from  
21 Churchill Falls to Wabush. This case requires 73 MVAR shunt compensation added to the 230 kV  
22 bus at FLK. The peak load of 434 MW is able to be met under this contingency. The restriction  
23 under this contingency is that SC1, SC2, and SC3 are at their maximum reactive power output.

24

25 With all equipment in service, a peak load of approximately 502 MW can be met.

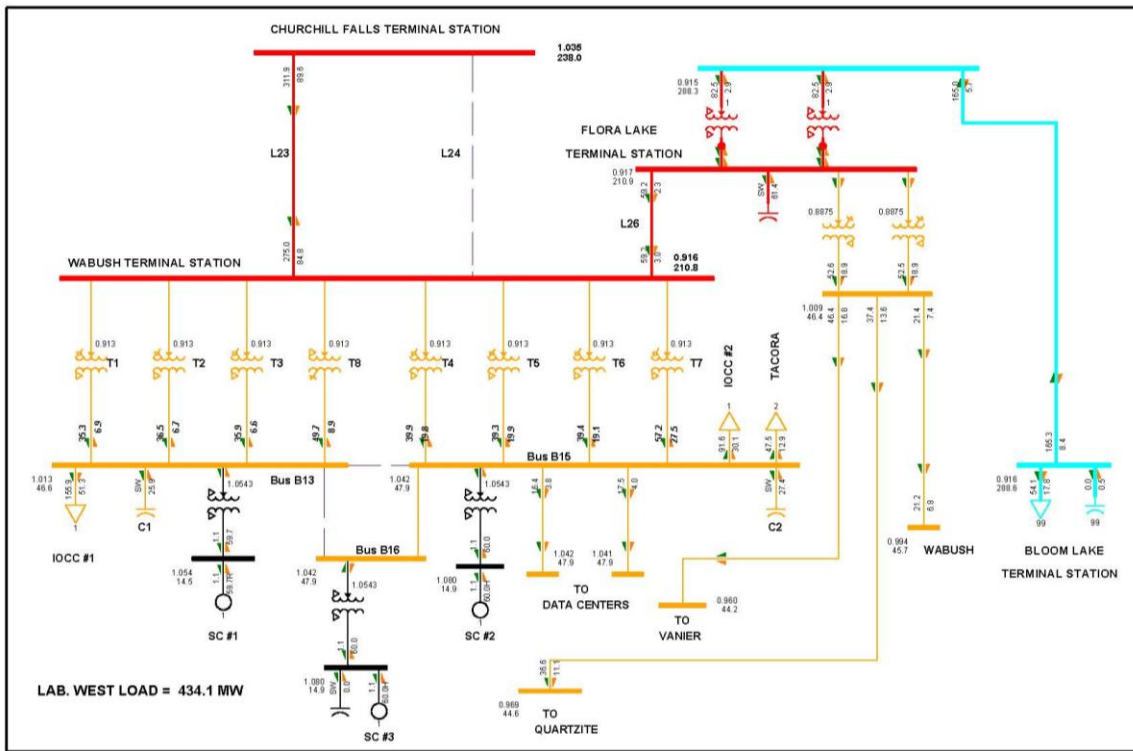

Figure A12: Alternative 9 – 2043 Peak Load Loss of L24

- 1 Costs associated with this alternative are summarized in Table A6.

Table A6: Summary of Costs for Alternative 9

Capital Work Required	Class 5 Estimate (\$ million)
Construction of 50 km of 315 kV transmission line from BLK to FLK and 5km of 230 kV from FLK to WTS.	74.70
BLK 315 kV Line Termination	2.90
WTS 230 kV Line Termination	1.66
Construction of new 315/230/46 kV terminal station at FLK	50.40
Installation of three 24.3 MVAR capacitor banks on FLK 230 kV Bus	5.11
Fully commission synchronous condenser SC3	0.50
Upgrade of 14 - 46 kV breakers with 2000 A, 31.5 kA breakers	4.00
25 km of new 46 kV lines plus upgrades to existing distribution lines	7.72
<b>Total</b>	<b>146.99</b>

- 2 The 315 kV transmission line is assumed to consist of twin Drake conductor with 75°C
- 3 conductor operating temperature complete with OPGW. The 230 kV transmission line from FLK



1 to WTS is assumed to be Grackle 1192.5 kcmil conductor with operating temperature of 75°C  
2 complete with OPGW. The new 315/230/46 kV terminal station at FLK would consist of two  
3 breaker and a half diameters for both the 315 and 230 kV sections. FLK terminal station to  
4 include two new 315/230/13.8 kV, 333 MVA auto-transformers complete with OLTCs, two new  
5 230/46 kV, 125 MVA transformers complete with OLTCs and 73 MVAR, 230 kV capacitor bank.

6  
7 **Alternative 10: 315 kV Interconnection from Churchill Falls to Flora Lake with 46**  
8 **kV Connection from Flora Lake**

9 Alternative 10 includes the construction of 210 km of overhead 315 kV transmission line from  
10 Churchill Falls to a new 315/230/46 kV terminal station at FLK, a new 5 km overhead 230 kV line  
11 from FLK to Wabush and installation of 29 MVAR of shunt compensation on the 230 kV bus at  
12 FLK. Commissioning of the third synchronous condenser at WTS and addition of 25 km of new  
13 46 kV lines plus 46 kV line thermal upgrades are required to prevent overload conditions. The  
14 estimated capital cost is \$335.86 million.

15  
16 For Alternative 10, the loss of any single component should not prevent the supply of the 2043  
17 peak load of 434 MW. Figure A13 outlines a scenario involving the loss of the new 315 kV line  
18 from Churchill Falls to FLK. This case requires 29 MVAR shunt compensation added to the 230  
19 kV bus at FLK. The peak load of 434 MW is able to be met under this contingency. The  
20 restriction under this contingency is that SC1, SC2, and SC3 are at their maximum reactive  
21 power output.

22  
23 With all equipment in service, a peak load of approximately 574 MW can be met.

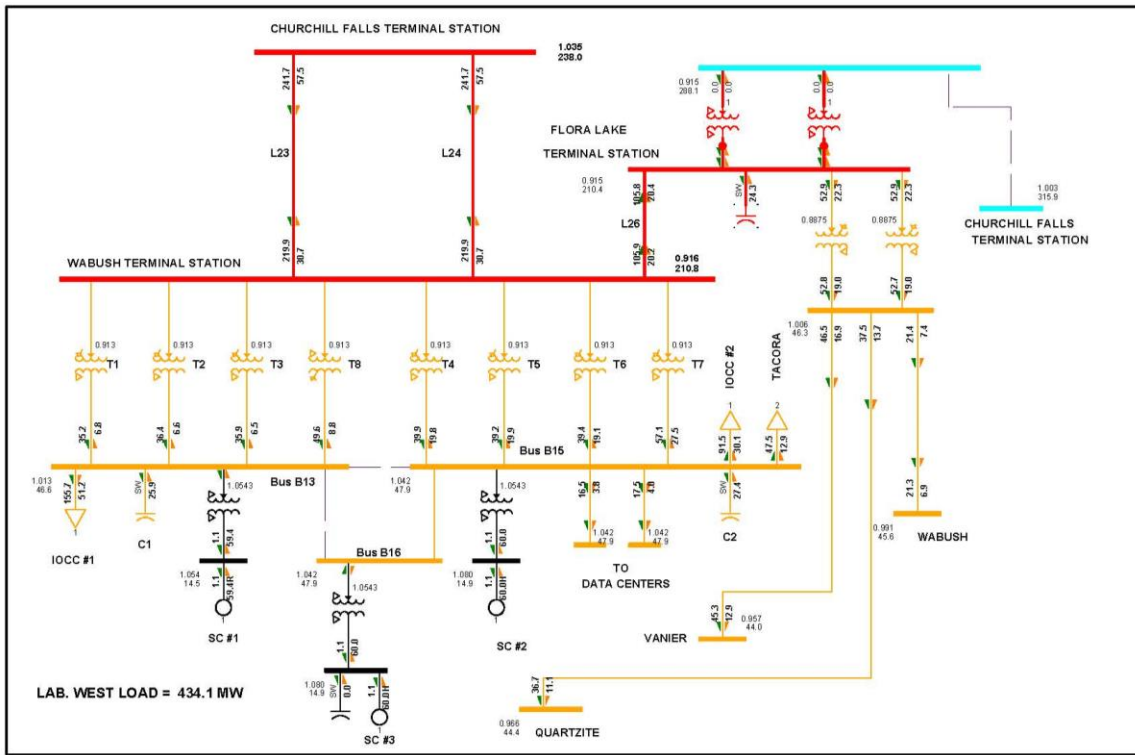

Figure A13: Alternative 10 – 2043 Peak Load Loss of Churchill Falls 315 kV Line

- Costs associated with this alternative are summarized in Table A7.

Table A7: Summary of Costs for Alternative 10

Capital Work Required	Class 5 Estimate (\$ million)
Construction of 210 km of 315 kV transmission line from CF to FLK and 5 km of 230 kV from FLK to WTS.	268.84
CF 315 kV Line Termination	2.00
WTS 230 kV Line Termination	1.66
Construction of new 315/230/46 kV terminal station at FLK	49.40
Installation of one, 29 MVAR capacitor bank on FLK 230 kV Bus	2.03
Fully commission synchronous condenser SC#3	0.50
Upgrade of 13, 46 kV breakers with 2000 A, 31.5 kA breakers	3.71
25 km of new 46 kV lines plus upgrades to existing distribution lines	7.72
<b>Total</b>	<b>335.86</b>

- The 315 kV transmission line is assumed to consist of twin Drake conductor with 75°C
- conductor operating temperature complete with OPGW. The 230 kV transmission line from FLK

1 to WTS is assumed to be Grackle 1192.5 kcmil conductor with operating temperature of 75°C  
2 complete with OPGW. The new 315/230/46 kV terminal station at FLK terminal station would  
3 consist of two breaker and a half diameters for both the 315 and 230 kV sections. FLK terminal  
4 station to include two new 315/230/13.8 kV, 333 MVA auto-transformers complete with OLTCs,  
5 two new 230/46 kV, 125 MVA transformers complete with OLTCs and 29 MVAR, 230 kV  
6 capacitor bank.

7

### 8 **Alternative 11: 315 kV Interconnection from Churchill Falls and Bloom Lake to** 9 **Flora Lake with 46 kV Connection from Flora Lake**

10 Alternative 11 includes the construction of 210 km of overhead 315 kV transmission line from  
11 Churchill Falls and construction of 26 to 50 km (TBD) of overhead 315 kV transmission line from  
12 BLK to a new 315/230/46 kV terminal station at FLK, a new 5 km overhead 230 kV line from FLK  
13 to Wabush. Commissioning of the third synchronous condenser at WTS and 25 km of new 46 kV  
14 lines plus 46 kV line thermal upgrades are required to prevent overload conditions. The  
15 estimated capital cost is \$397.97 million.

16

17 For Alternative 11, the loss of any single component should not prevent the supply of the 2043  
18 peak load of 434 MW. Figure A14 outlines a scenario involving the loss of the new 315 kV line  
19 from Churchill Falls to FLK. A peak load of 473 MW is able to be met under this contingency.  
20 The restriction under this contingency is that SC1, SC2, and SC3 are at their maximum reactive  
21 power output.

22

23 With all equipment in service, a peak load of approximately 563 MW can be met.

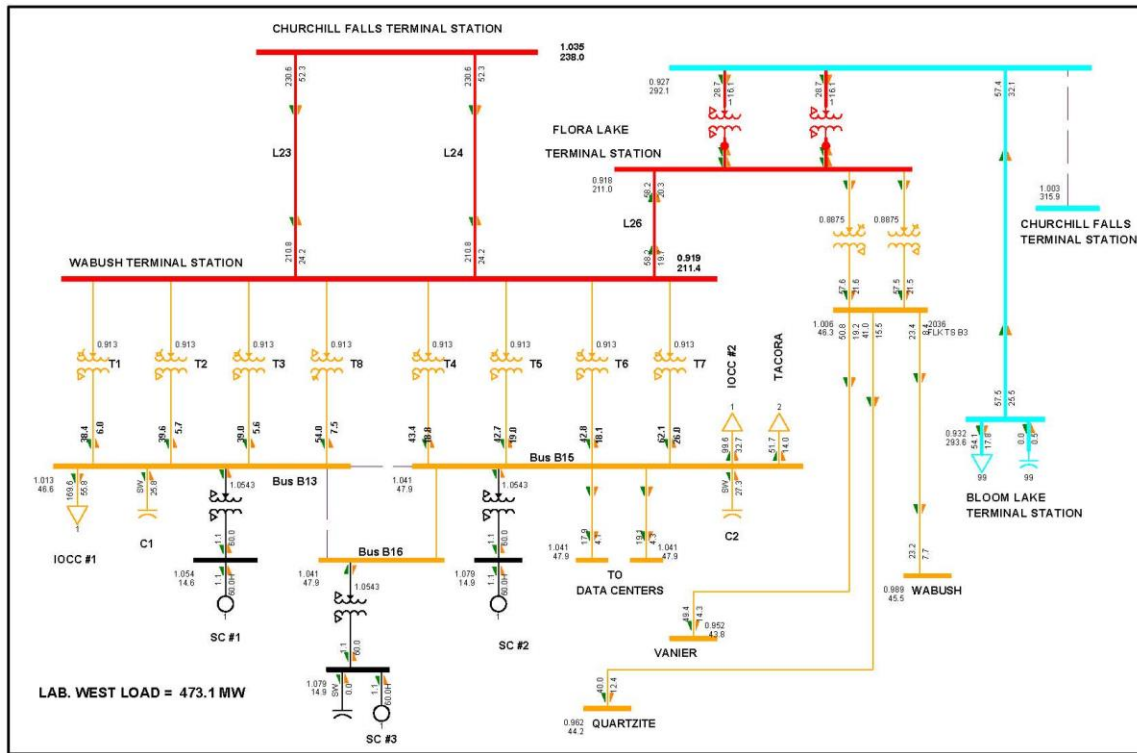

Figure A14: Alternative 11 – 2043 Peak Load Loss of Churchill Falls 315 kV Line

- Costs associated with this alternative are summarized in Table A8.

Table A8: Summary of Costs for Alternative 11

Capital Work Required	Class 5 Estimate (\$ million)
Construction of 210 km of 315 kV transmission line from CF to FLK and 50 km from BLK to FLK, 5 km of 230 kV from FLK to WTS.	331.14
CF 315 kV Line Termination	2.00
BLK 315 kV Line Termination	2.90
WTS 230 kV Line Termination	1.66
Construction of new 315/230/46 kV terminal station at FLK	49.20
Fully commission synchronous condenser SC3	0.50
Upgrade of ten, 46 kV breakers with 2000 A, 31.5 kA breakers	2.85
25 km of new 46 kV lines plus upgrades to existing distribution lines	7.72
<b>Total</b>	<b>397.97</b>

- The 315 kV transmission line is assumed to consist of twin Drake conductor with 75°C
- conductor operating temperature complete with OPGW. The 230 kV transmission line is
- assumed to be Grackle 1192.5 kcmil conductor with operating temperature of 75°C complete

1 with OPGW. The new 315/230/46 kV terminal station at FLK would consist of two breaker and a  
2 half diameters for both the 315 and 230 kV sections. FLK terminal station to include two new  
3 315/230/13.8 kV, 333 MVA auto-transformers complete with OLTCs, two new 230/46 kV, 125  
4 MVA transformers complete with OLTCs.

5

## 6 **Alternative 12: 200 kV VSC HVdc Monopole Transmission Line from Bloom Lake** 7 **to Flora Lake with 46 kV Connection from Flora Lake**

8 Alternative 12 includes the construction of 50 km of overhead 200 kV HVdc Monopole  
9 transmission line from BLK to a new 200kV HVdc - 230/46 kV terminal station at FLK. BLK and  
10 FLK will have a VSC converter with rating of 250 MW/125 MVAR complete with 60 MVAR filter  
11 bank, construction of a new 5 km overhead 230 kV line from FLK to Wabush, commissioning of  
12 the third synchronous condenser at WTS, and 25 km of new 46 kV lines plus 46 kV line thermal  
13 upgrades required to prevent overload conditions. The estimated capital cost is \$347.90  
14 million.

15

16 For Alternative 12, the loss of any single component should not prevent the supply of the 2043  
17 peak load of 434 MW. Figure A15 outlines a scenario involving the loss of the converter at FLK.  
18 A peak load of 453 MW is able to be met under this contingency with the 60 MVAR filter bank  
19 remains in-service. The restriction under this contingency is that SC1, SC2, and SC3 are at their  
20 maximum reactive power output.

21

22 With all equipment in service, a peak load of approximately 585 MW can be met.

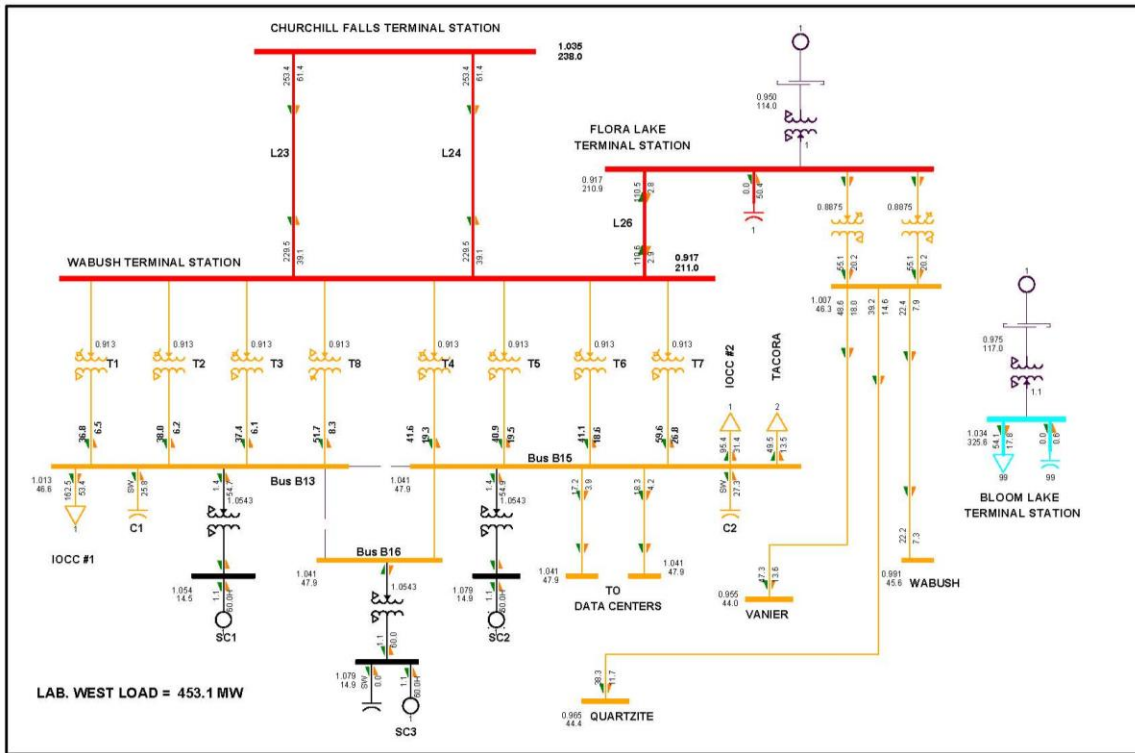

Figure A15: Alternative 12 – 2043 Peak Load Converter Outage at Flora Lake

- 1 Costs associated with this alternative are summarized in Table A9.

Table A9: Summary of Costs for Alternative 12

Capital Work Required	Class 5 Estimate (\$ million)
Construction of 50 km of 200 kV Monopole HVdc transmission line from BLK to FLK, 5 km of 230 kV from FLK to WTS.	94.48
BLK 315 kV Line Termination	2.90
Construction of FLK and BLK Converter Building with 60 MVAR filter bank at each location.	214.00
Construction of new 230/46 kV terminal station at FLK	25.50
WTS 230 kV Line Termination	1.66
Fully commission synchronous condenser SC3	0.50
Upgrade of four, 46 kV breakers with 2000 A, 31.5 kA breakers	1.14
25 km of new 46 kV lines plus upgrades to existing distribution lines	7.72
<b>Total</b>	<b>347.90</b>

- 2 The 200 kV Monopole HVdc transmission line with metallic return is assumed to consist of
- 3 Bluebird 2156 kcmil ACSR conductor with 75°C conductor operating temperature complete with

1 OPGW. The 230 kV transmission line is assumed to be Grackle 1192.5 kcmil conductor with  
2 operating temperature of 75°C complete with OPGW. The converter stations at both BLK and  
3 FLK shall be rated at 250 MW and include major components such as 60 MVAR filter bank, 300  
4 MVA converter transformers, valve bridges, and associated equipment. The terminal station at  
5 FLK shall come complete with two new 230/46 kV – 125 MVA transformers complete with  
6 OLTCs.

7

### 8 **Alternative 13: HVdc VSC Back-to-Back Converter at Bloom Lake – 230 kV**

#### 9 **Transmission Line from Bloom Lake to Flora Lake with 46 kV Connection from** 10 **Flora Lake**

11 Alternative 13 includes the construction of a 250 MW Back to Back HVdc Converter at Bloom  
12 Lake and 50 km of overhead 230 kV ac transmission line from Bloom Lake to a new 230/46 kV  
13 Terminal Station at FLK. A 29 MVAR shunt compensation to be installed at FLK 230 kV bus,  
14 construction of a new 5 km overhead 230 kV line from FLK to Wabush. Commissioning of the  
15 third synchronous condenser at WTS and 25 km of new 46 kV lines plus 46 kV line thermal  
16 upgrades are required to prevent overload conditions. The estimated capital cost is \$233.16  
17 million.

18

19 For Alternative 13, the loss of any single component should not prevent the supply of the 2043  
20 peak load of 434 MW. Figure A16 outlines a scenario involving the loss of the 230 kV line from  
21 BLK. The peak load of 434 MW is able to be met under this contingency with a 29 MVAR  
22 capacitor bank at FLK. The restriction under this contingency is SC1, SC2 and SC3 being at their  
23 maximum reactive power output.

24

25 With all equipment in service, a peak load of approximately 612 MW can be met.

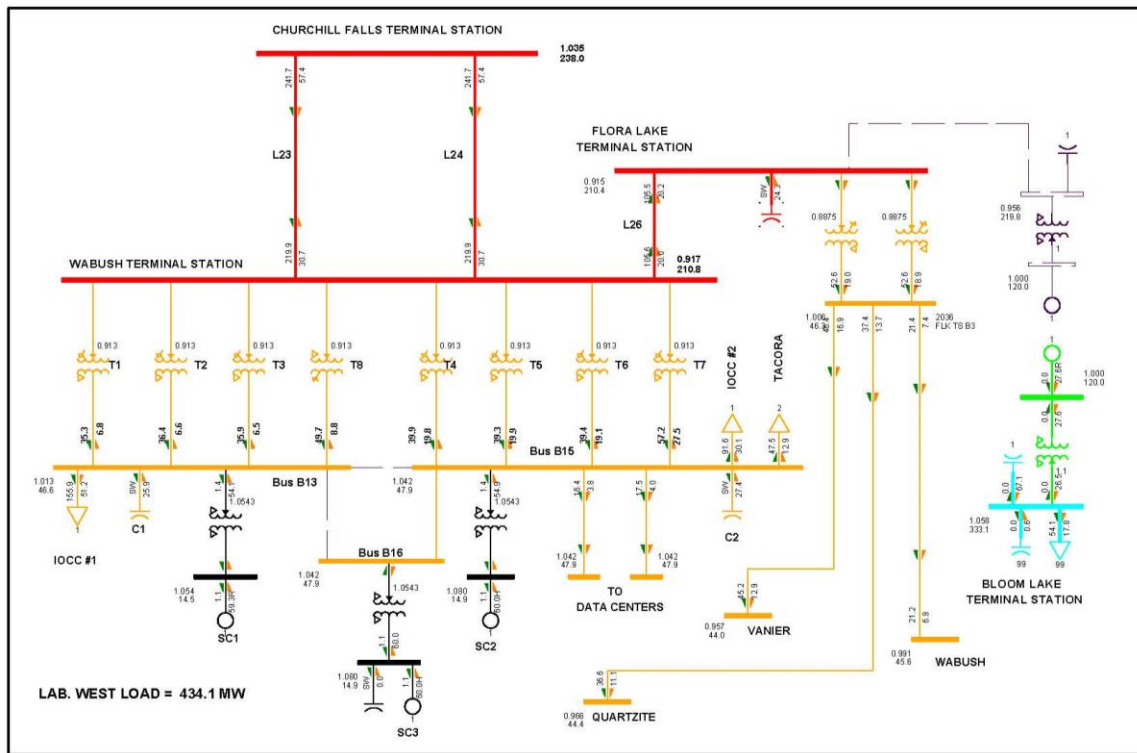

Figure A16: Alternative 13 – 2043 Peak Load 230 kV Line Outage from Bloom Lake

1 Costs associated with this alternative are summarized in Table A10.

Table A10: Summary of Costs for Alternative 13

Capital Work Required	Class 5 Estimate (\$ million)
Construction of 50 km of 230 kV AC transmission line from BLK to FLK, 5 km of 230 kV from FLK to WTS.	58.40
Construction of HVdc - VSC Back-to-Back Converter at BLK with rating of 300 MW	130
BLK 315 kV and 230 kV Line Terminations	4.50
Construction of new 230/46 kV terminal station at FLK	25.50
Installation of one, 29 MVAR capacitor bank on FLK 230 kV Bus	2.03
WTS 230 kV Line Termination	1.66
Fully commission synchronous condenser SC#3	0.50
Upgrade of ten, 46 kV breakers with 2000 A, 31.5 kA breakers	2.85
25 km of new 46 kV lines plus upgrades to existing distribution lines	7.72
<b>Total</b>	<b>233.16</b>



1 The 230 kV transmission lines are assumed to be Grackle 1192.5 kcmil conductor with operating  
2 temperature of 75°C complete with OPGW. The VSC back-to-back converter at BLK is assumed  
3 to have a rating of 300 MW, including major components such as filters, 300 MVA converter  
4 transformers, valve bridges, and associated equipment. Input voltage of 315 kV and output  
5 voltage of 230 kV. The terminal station at FLK shall come complete with two new 230/46 kV –  
6 125 MVA transformers complete with OLTCs.

7

## 8 **Alternative 14: HVdc VSC Back-to-Back Converter at Bloom Lake – 230 kV**

### 9 **Transmission Line from Bloom Lake to Wabush**

10 Alternative 14 includes the construction of a 250 MW back-to-back HVdc converter at BLK and a  
11 26 to 50 km (TBD) of overhead 230 kV ac transmission line from BLK to WTS. At WTS a 19 MVAR  
12 shunt capacitor bank on the 46 kV bus, commissioning of the third synchronous condenser and  
13 replacement of transformers T4, T5, and T6 with 125 MVA units as well as 46 kV line thermal  
14 upgrades are required to prevent overload conditions. The estimated capital cost \$216.70  
15 million.

16

17 For Alternative 14, the loss of any single component should not prevent the supply of the 2043  
18 peak load of 434 MW. Figure A17 outlines a scenario involving the loss of the 230 kV line from  
19 BLK. The peak load of 434 MW is able to be met under this contingency with a 19 MVAR  
20 capacitor bank at Wabush. The restriction under this contingency is SC1, SC2, and SC3 being at  
21 their maximum reactive power output.

22

23 With all equipment in service, a peak load of approximately 603 MW can be met.

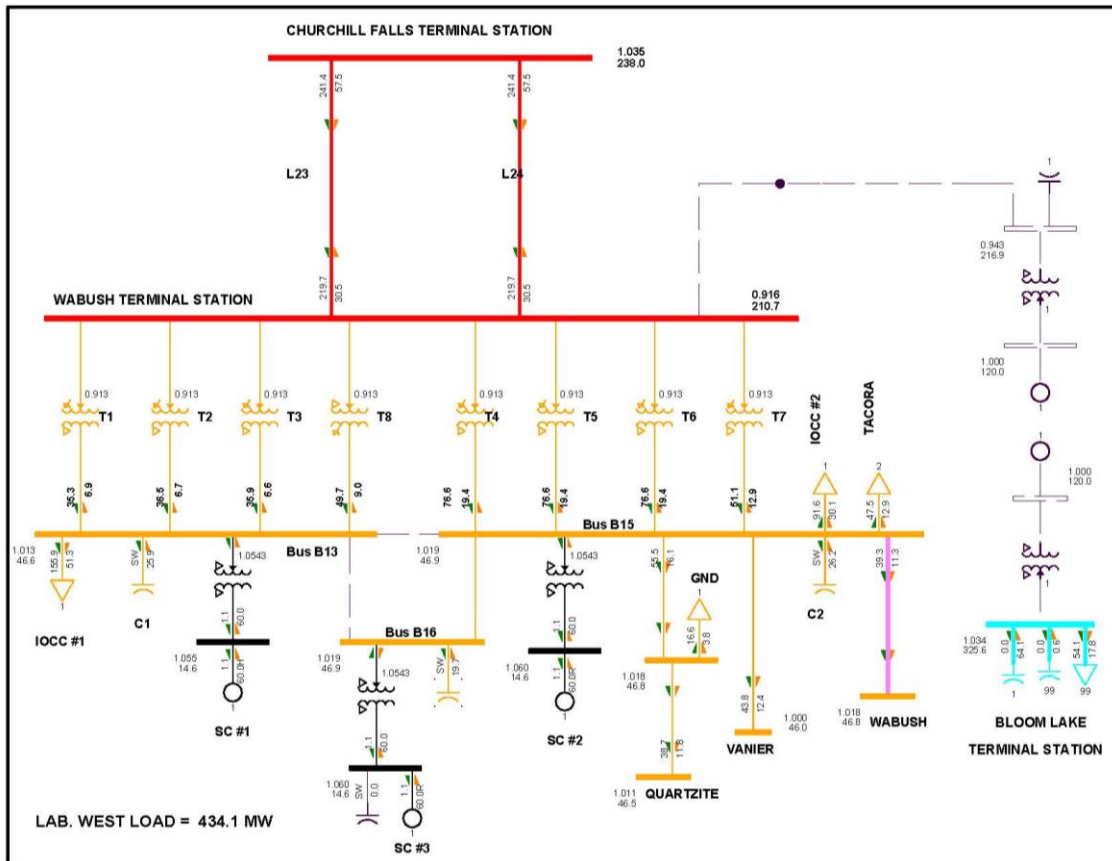

Figure A17: Alternative 14 – 2043 Peak Load 230 kV Line Outage from Bloom Lake

- Costs associated with this alternative are summarized in Table A11.

Table A11: Summary of Costs for Alternative 14

Capital Work Required	Class 5 Estimate (\$ million)
Construction of 55 km of 230 kV AC transmission line from BLK to WTS.	58.40
Construction of HVDC - VSC back-to-back converter at BLK with rating of 300 MW	130
BLK 315 kV and 230 kV Line Terminations	4.50
WTS 230 kV Line Termination	1.66
Installation of one, 19 MVAR capacitor bank on 46 kV Bus B16	1.33
Replace 65 MVA transformers T4, T5 and T6 with 125 MVA units, complete with OLTC.	15.63
Fully commission synchronous condenser SC3	0.50
Upgrade of ten, 46 kV breakers with 2000 A, 31.5 kA breakers	2.85
46 kV upgrades to distribution lines	1.82
<b>Total</b>	<b>216.70</b>

1 The 230 kV transmission line is assumed to be Grackle 1192.5 kcmil conductor with operating  
2 temperature of 75°C complete with OPGW. The VSC back-to-back converter at BLK is assumed  
3 to have a rating of 300 MW, including major components such as filters, 300 MVA converter  
4 transformers, valve bridges, and associated equipment. Input voltage of 315 kV and output  
5 voltage of 230 kV.

6

### 7 **Alternative 15: 200 MW of Gas Turbines at Wabush Terminal Station**

8 Alternative 15 includes the installation of four, 50 MW gas turbines complete with synchronous  
9 condenser capability. At WTS, commissioning of the third synchronous condenser, replacement  
10 of transformers T4, T5, and T6 with 125 MVA units as well as 46 kV line thermal upgrades are  
11 required to prevent overload conditions. The estimated capital cost is \$589.20 million.

12

13 For Alternative 15, the loss of any single component should not prevent the supply of the 2043  
14 peak load of 434 MW. Figure A18 outlines a scenario involving the loss of the 230 kV line from  
15 Churchill Falls. The peak load of 434 MW is able to be met under this contingency with a 140  
16 MW from the gas turbine to minimize line overloading and maintain acceptable voltages at  
17 Wabush.

18

19 With all equipment in service, a peak load of approximately 573 MW can be met with the gas  
20 turbines operating at 200 MW.

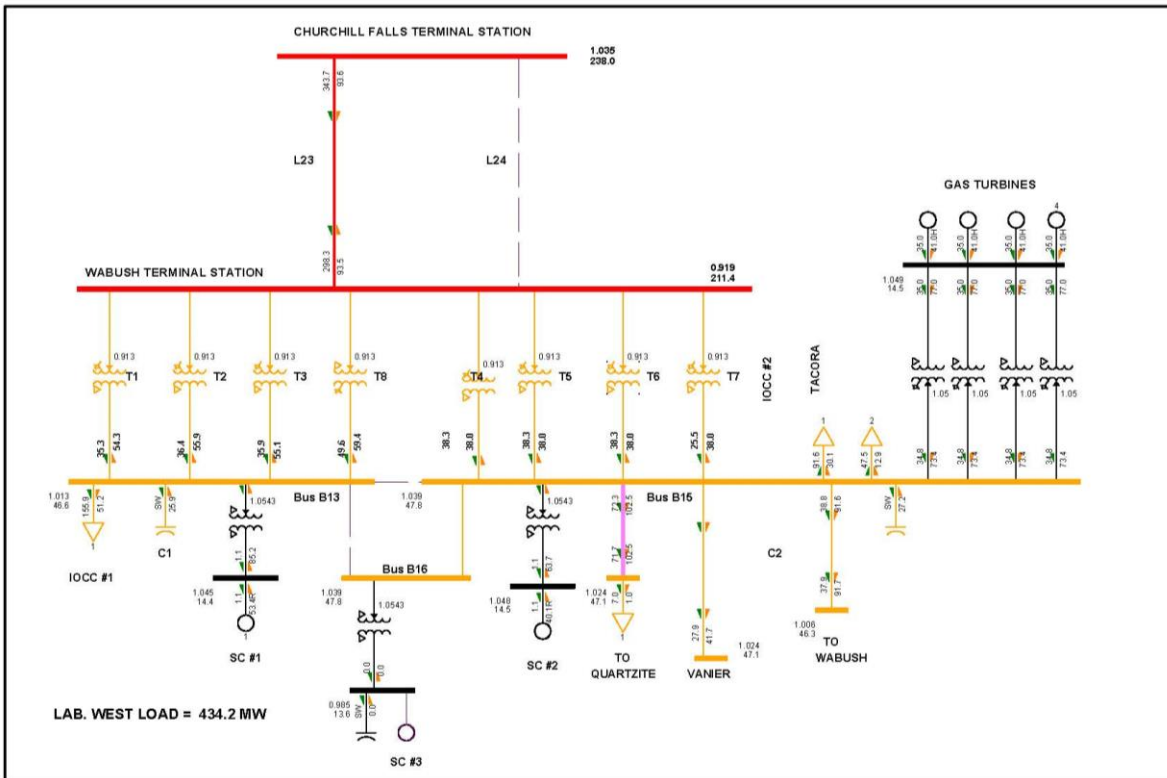

Figure A18: Alternative 15 – 2043 Peak Load 230 kV Line L24 Outage from Churchill Falls

- Costs associated with this alternative are summarized in Table A12.

Table A12: Summary of Costs for Alternative 15

Capital Work Required	Class 5 Estimate (\$ million)
Installation of four, 50 MW gas turbines complete with synchronous condenser capability at WTS, complete with fuel storage facility (5-day storage)	567.44
Replace 65 MVA transformers T4, T5, and T6 with 125 MVA units, complete with OLTC	15.63
Upgrade of 15, 46 kV breakers with 2000 A, 31.5 kA breakers	4.28
46 kV upgrades to distribution lines	1.82
<b>Total</b>	<b>589.20</b>

1 **Alternative 16: New 230kV Transmission Line from Churchill Falls to Flora Lake**

2 Alternative 16 includes the construction of 210 km of overhead 230 kV transmission line from  
3 Churchill Falls to a new 230/46 kV Terminal Station at FLK, new 5 km overhead 230 kV line from  
4 FLK to Wabush, commissioning of the third synchronous condenser at Wabush and installation  
5 of 126 MVAR of shunt compensation on the 230 kV bus at FLK. Also required would be 25 km of  
6 new 46 kV lines plus 46 kV line thermal upgrades are required to prevent overload conditions.  
7 The estimated capital cost is \$279.72 million.

8

9 For Alternative 16, the loss of any single component should not prevent the supply of the 2043  
10 peak load of 499 MW. Figure A19 outlines a scenario involving the loss of the 230 kV line from  
11 Churchill Falls. The peak load of 499 MW is able to be met under this contingency.

12

13 With all equipment in service, a peak load of approximately 636 MW can be met.

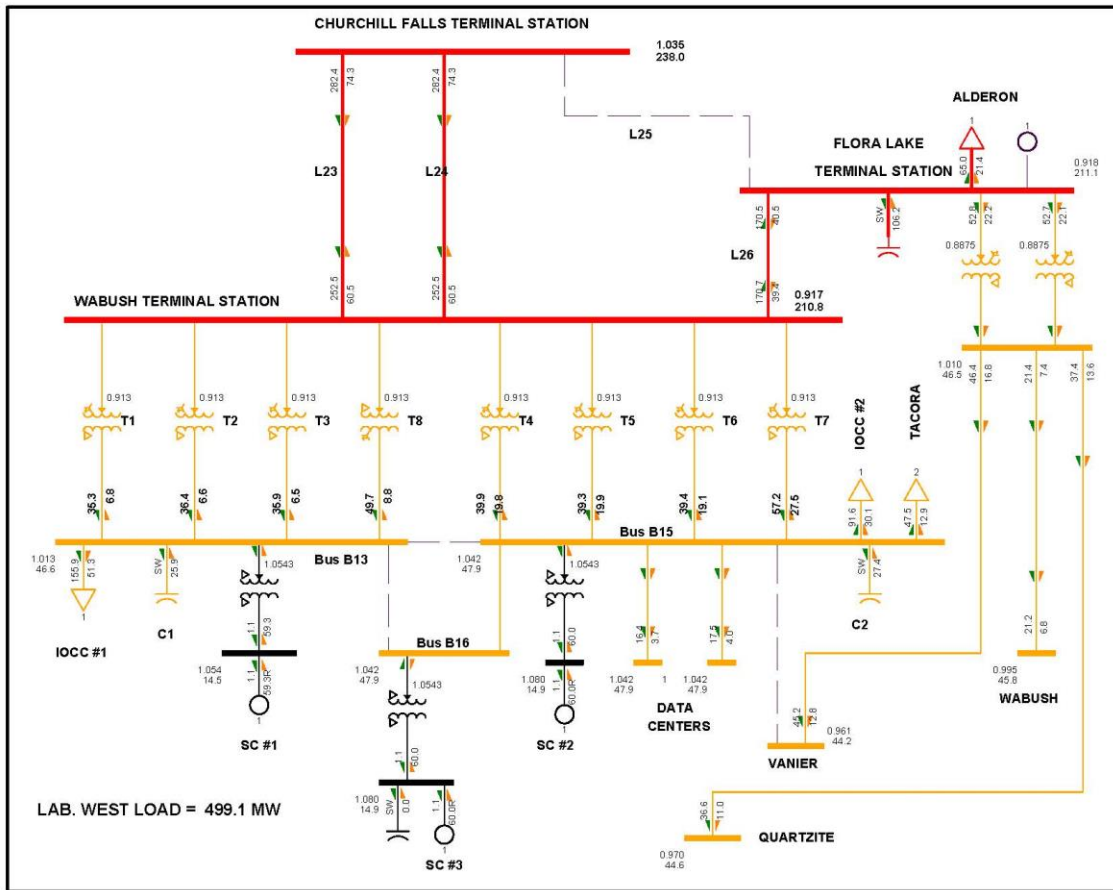

Figure A19: Alternative 16 – 2043 Peak Load 230 kV Line L25 Outage from Churchill Falls

- Costs associated with this alternative are summarized in Table A13.

Table A13: Summary of Costs for Alternative 16

Capital Work Required	Class 5 Estimate (\$ million)
Construction of 210 km of 230 kV line from CF to FLK and 5 km of 230 kV line from FLK to WTS	228.38
CF 230 kV Line Termination	1.89
WTS 230 kV Line Termination	1.66
Construction of new 230/46 kV terminal station at FLK	27.90
Fully commission synchronous condenser SC3	0.50
Installation of four, 31.5 MVAR capacitor bank on FLK 230kV Bus	8.82
Upgrade of ten, 46 kV breakers with 2000 A, 31.5 kA breakers	2.85
25 km of new 46 kV lines plus upgrades to existing distribution lines	7.72
<b>Total</b>	<b>279.72</b>

1 The 230 kV transmission line from Churchill Falls to FLK to Wabush would have an assumed  
2 Grackle 1192.5 kcmil conductor with operating temperature of 75°C complete with OPGW. The  
3 new 230/46 kV terminal station at FLK terminal station would consist of two breaker and a third  
4 diameters, two new 230/46 kV, 125 MVA transformers complete with OLTCs and 126 MVAR,  
5 230 kV capacitor bank.

6

7 **Alternative 17: New 315 kV Transmission Line from Bloom Lake to Flora Lake**  
8 **with 46 kV Connection from Flora Lake**

9 Alternative 17 includes the construction of 26 to 50 km (TBD) of overhead 315 kV transmission  
10 line from BLK to a new 315/230/46 kV terminal station at FLK, a new 5 km overhead 230 kV line  
11 from FLK to Wabush and installation of 161 MVAR of shunt compensation on the 230 kV bus at  
12 FLK. Commissioning of the third synchronous condenser and 25 km of new 46 kV lines plus 46  
13 kV line thermal upgrades are required to prevent overload conditions. The estimated capital  
14 cost is \$153.15 million.

15

16 For Alternative 17, the loss of any single component should not prevent the supply of the 2043  
17 peak load of 499 MW. Figure A20 outlines a scenario involving the loss of 230 kV line L24 from  
18 Churchill Falls to Wabush. This case requires 161 MVAR shunt compensation added to the 230  
19 kV bus at FLK. The peak load of 499 MW is able to be met under this contingency. The  
20 restriction under this contingency is that SC1, SC2, and SC3 are at their maximum reactive  
21 power output.

22

23 For no equipment outage, peak load of approximately 600 MW can be met.

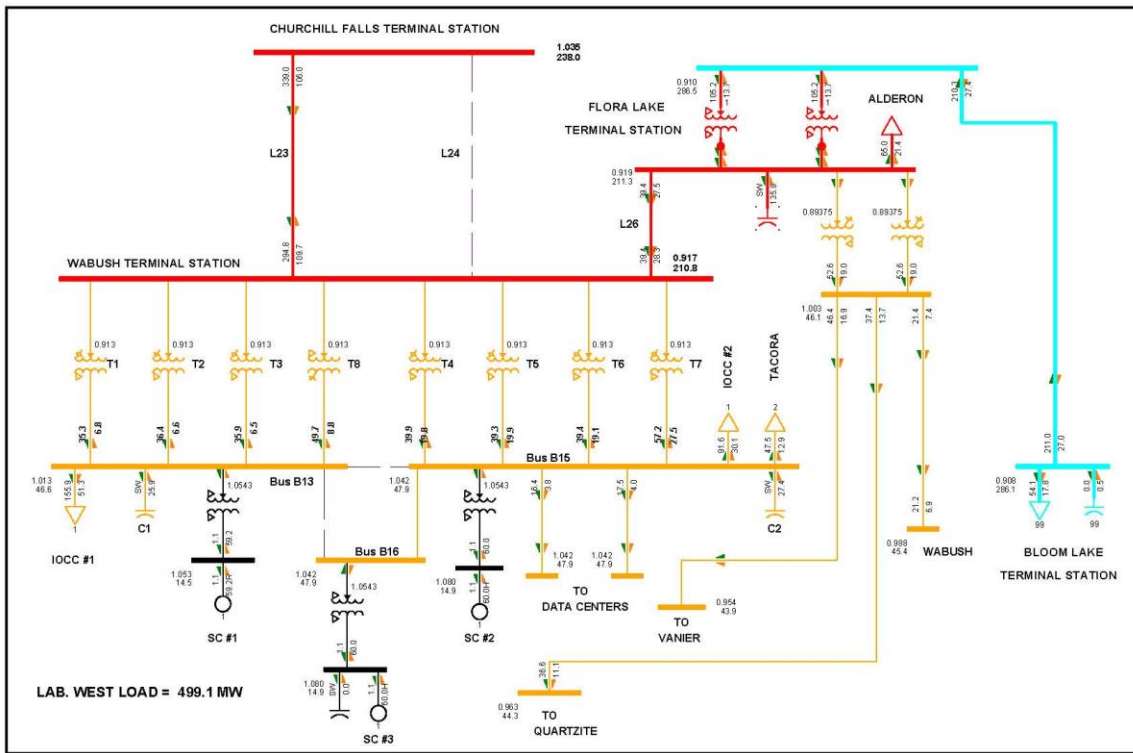

Figure A20: Alternative 17 – 2043 Peak Load Loss of L24

- Costs associated with this alternative are summarized in Table A14.

Table A14: Summary of Costs for Alternative 17

Capital Work Required	Class 5 Estimate (\$ million)
Construction of 50 km of 315 kV transmission line from BLK to FLK and 5 km of 230 kV from FLK to WTS.	74.70
BLK 315 kV Line Termination	2.90
WTS 230 kV Line Termination	1.66
Construction of new 315/230/46 kV terminal station at FLK	50.40
Installation of four, 40.25 MVAR capacitor banks on FLK 230kV Bus	11.27
Fully commission synchronous condenser SC3	0.50
Upgrade of 14, 46 kV breakers with 2000 A, 31.5 kA breakers	4.00
25 km of new 46 kV lines plus upgrades to existing distribution lines	7.72
<b>Total</b>	<b>153.15</b>



## **Appendix B**

### Labrador West Future Transmission Supply Alternatives Single Line Diagrams

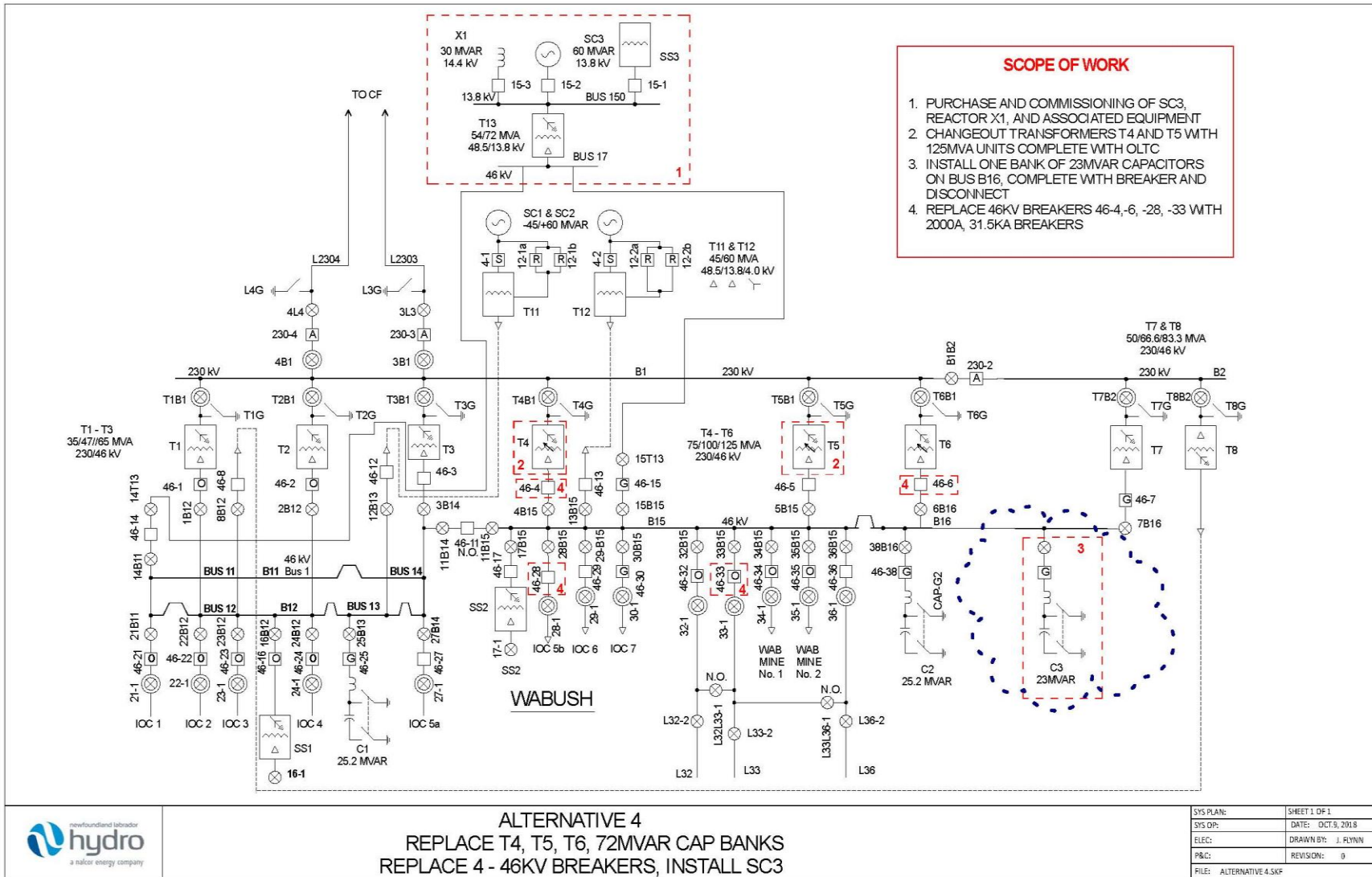

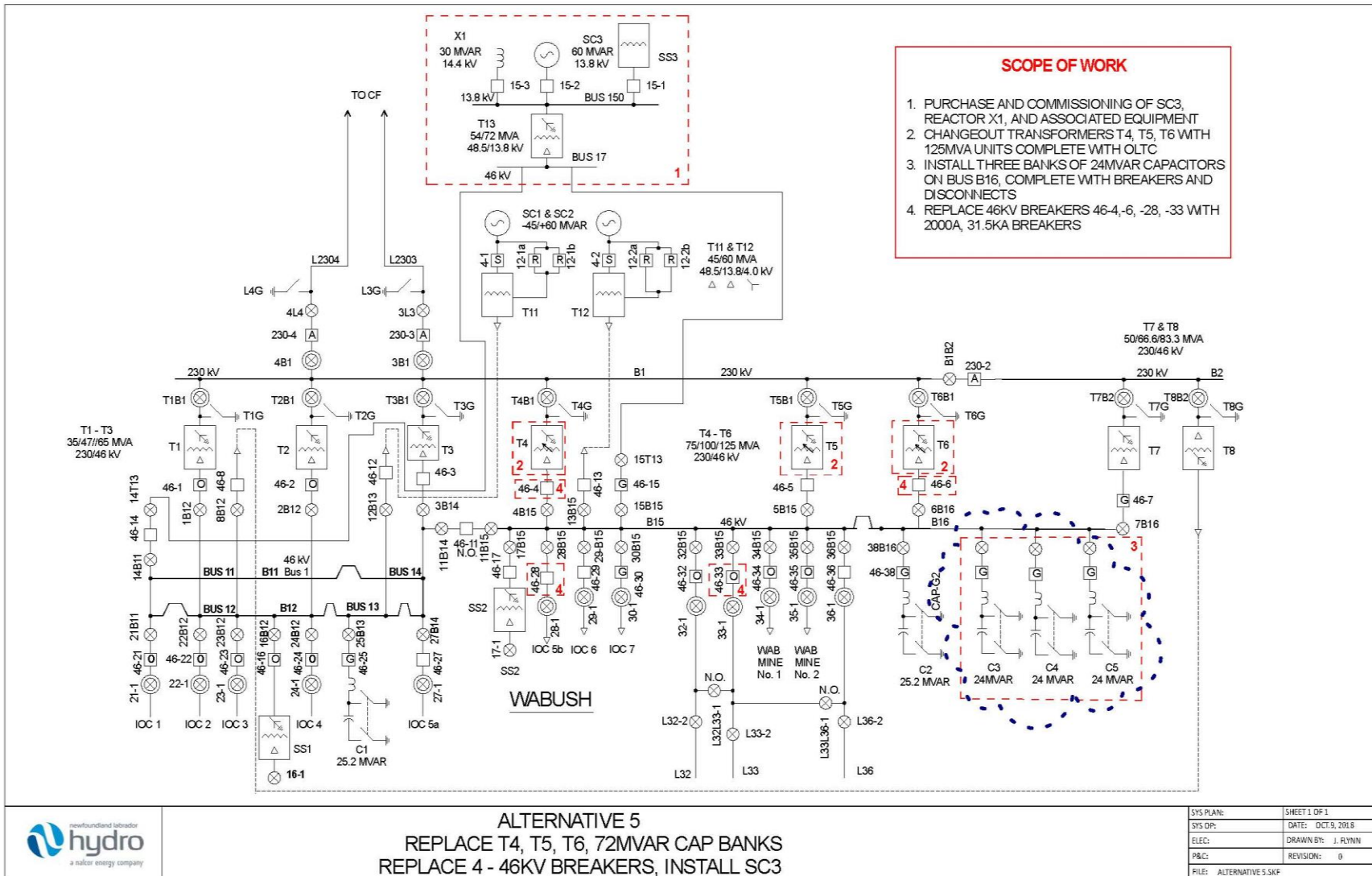

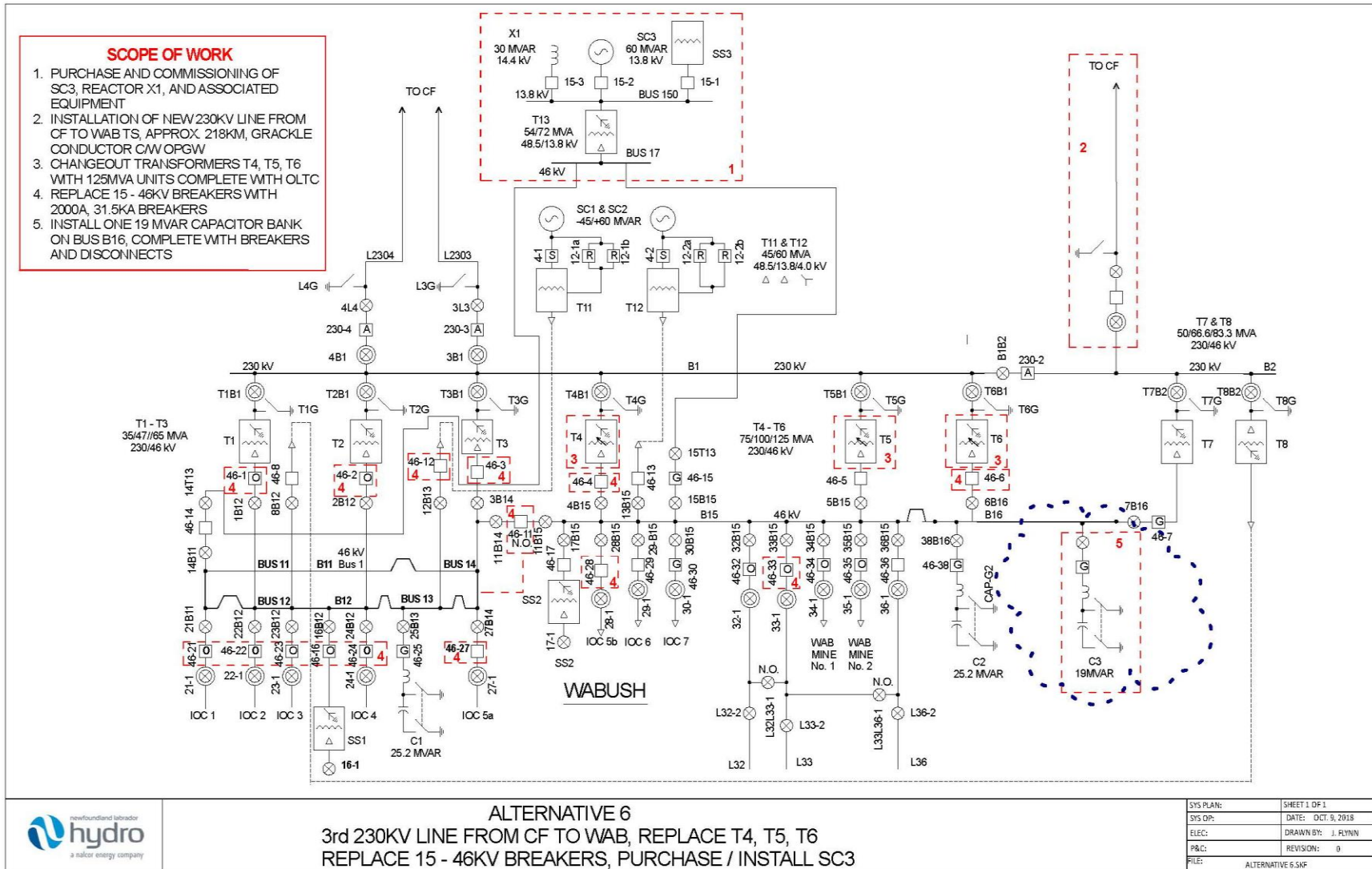

**ALTERNATIVE 5**  
 REPLACE T4, T5, T6, 72MVAR CAP BANKS  
 REPLACE 4 - 46KV BREAKERS, INSTALL SC3

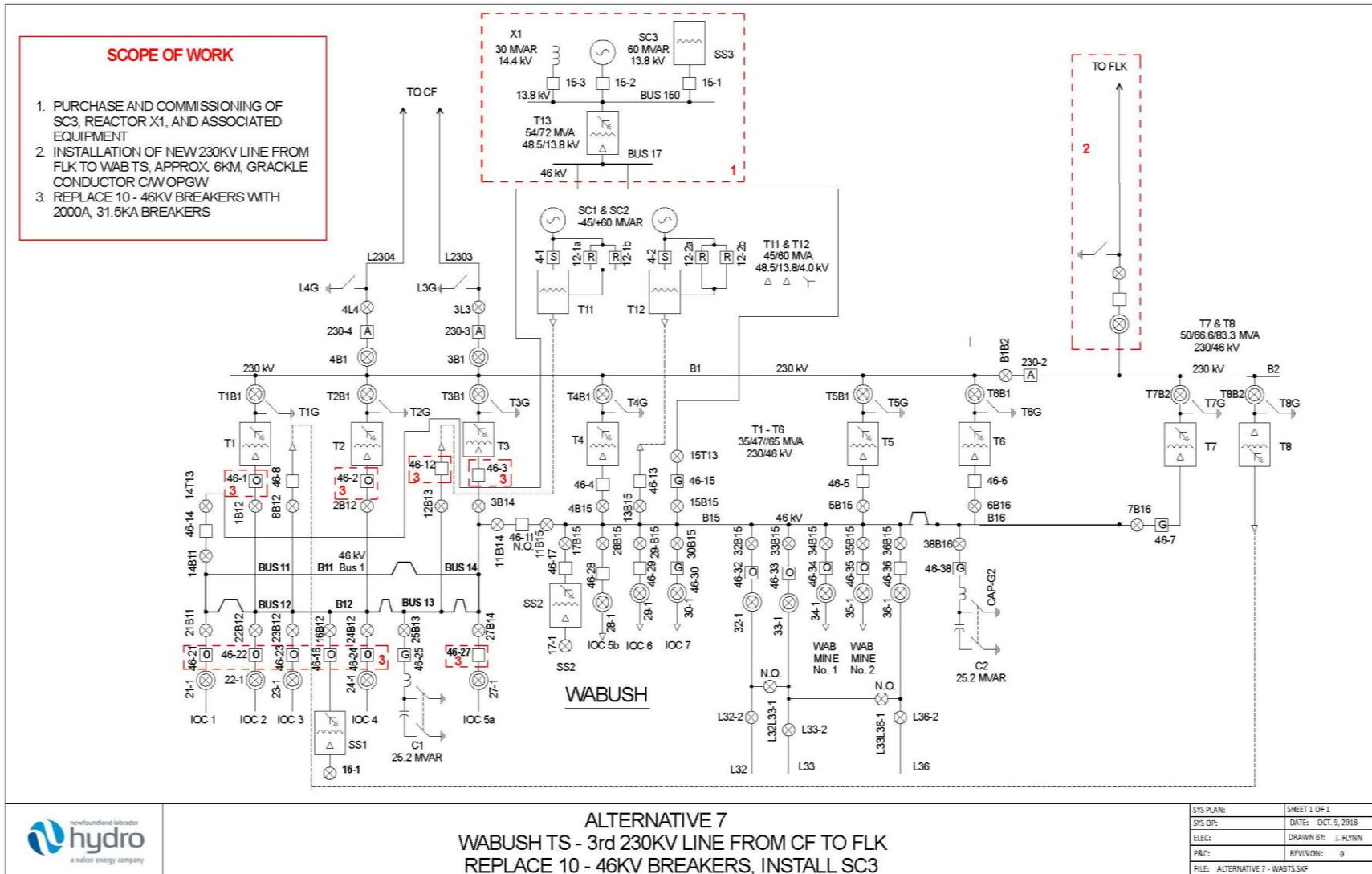



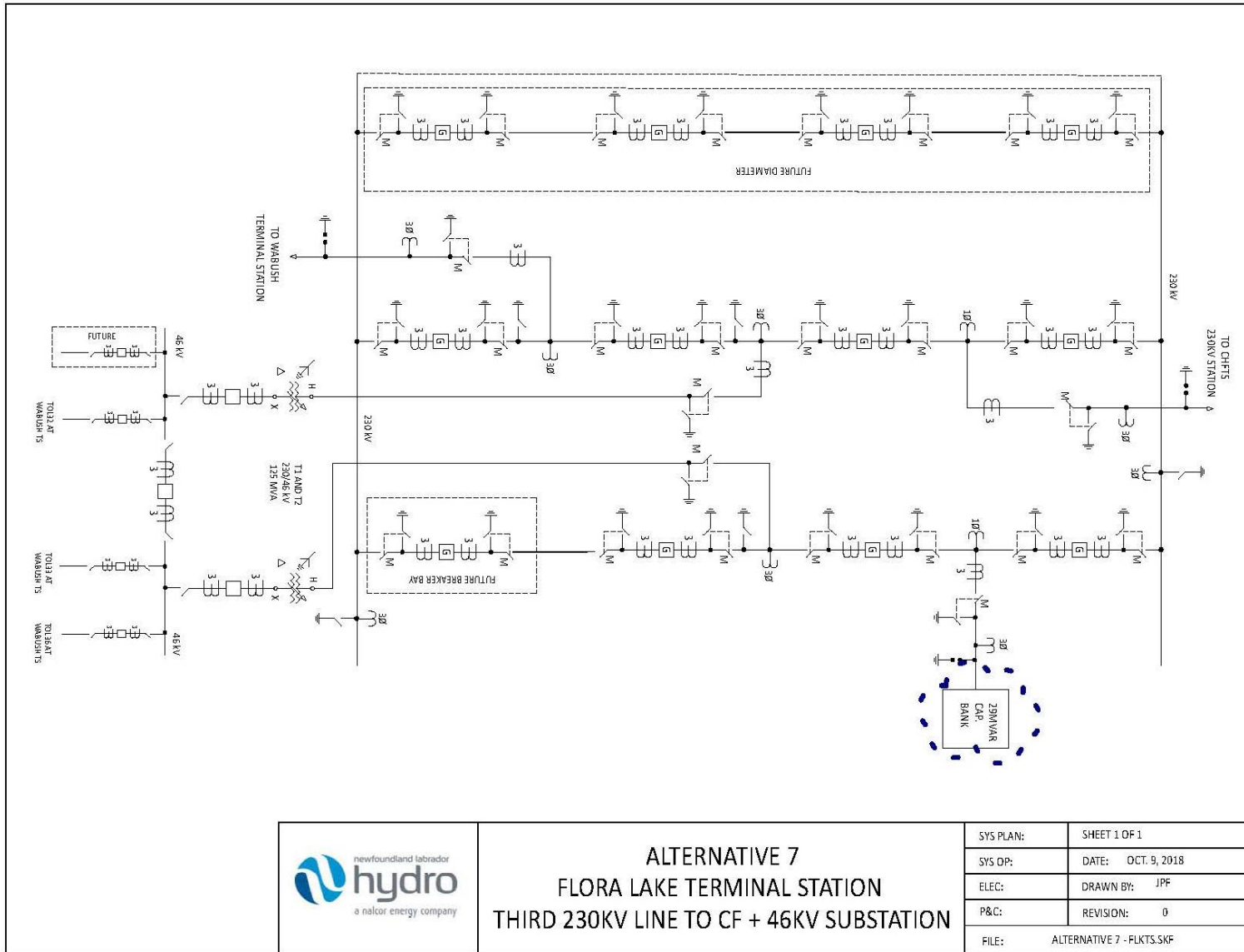



 <p>newfoundland labrador <b>hydro</b> a nalcor energy company</p>	<p><b>ALTERNATIVE 7</b>                  FLORA LAKE TERMINAL STATION                  THIRD 230KV LINE TO CF + 46KV SUBSTATION</p>		SYS PLAN: SHEET 1 OF 1
			SYS OP: DATE: OCT. 9, 2018
			ELEC: DRAWN BY: JPF
			P&C: REVISION: 0
			FILE: ALTERNATIVE 7 - FLKTS.SKF

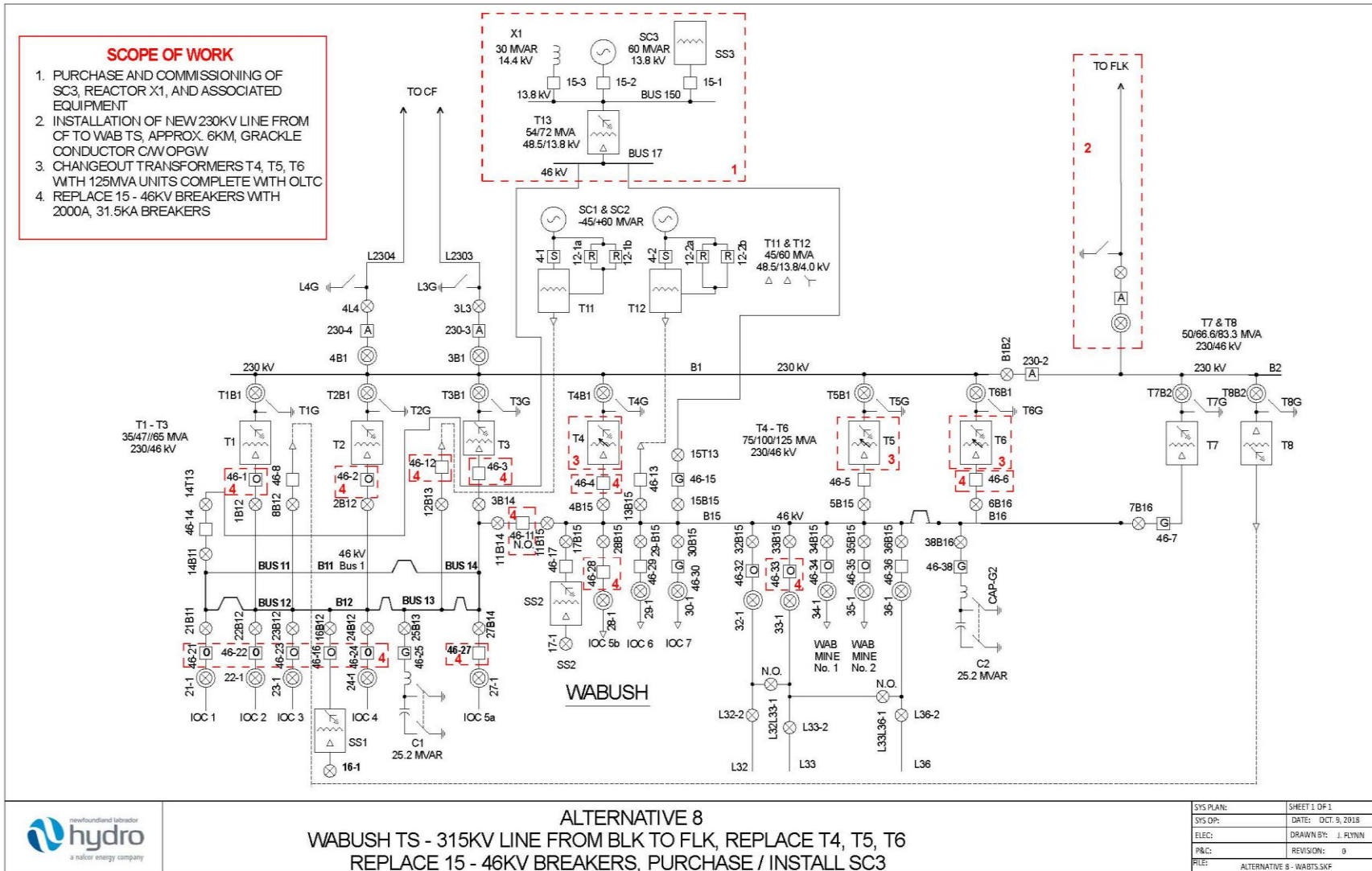

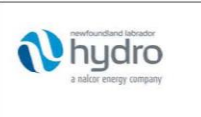
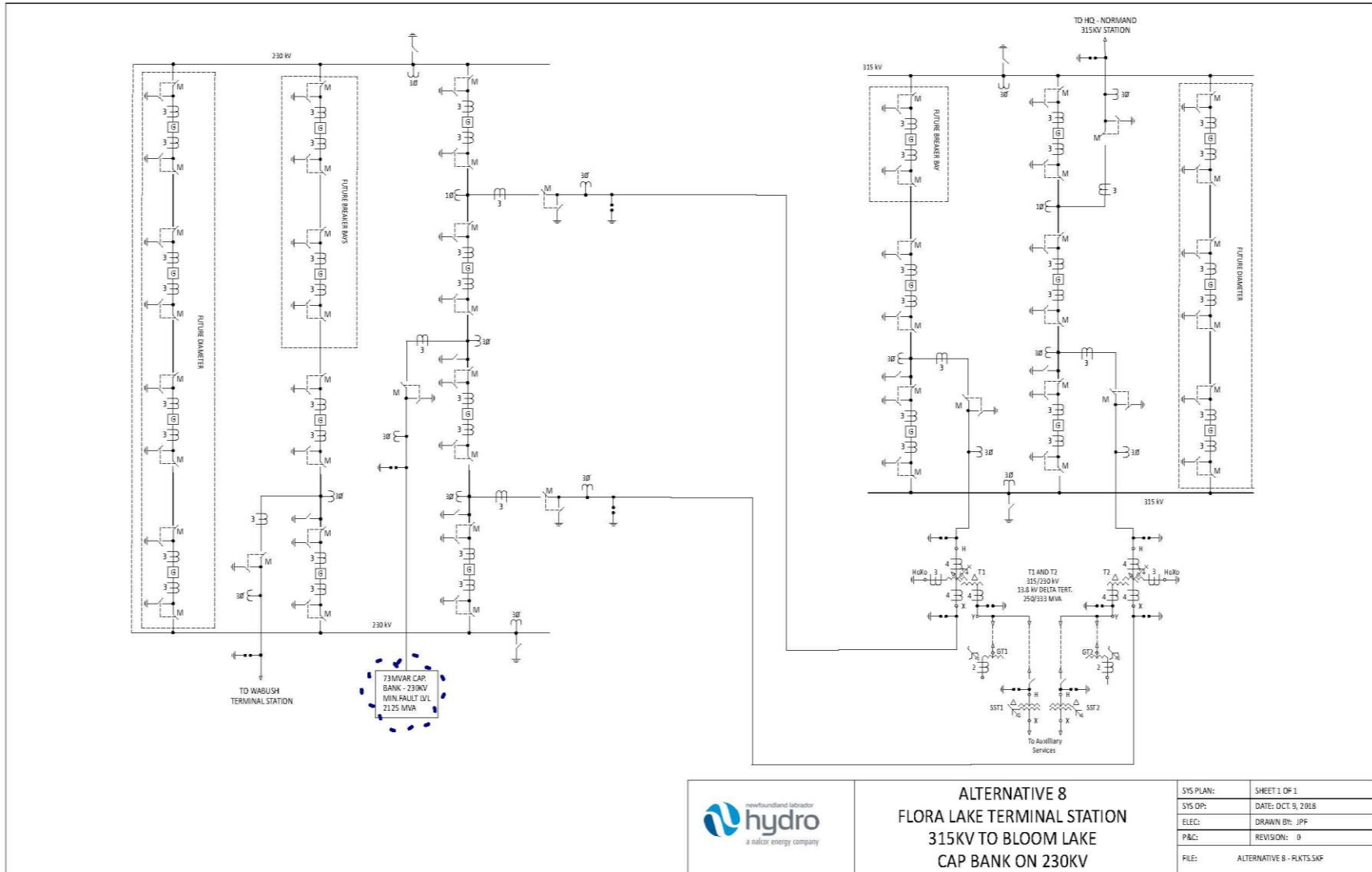

**ALTERNATIVE 8**  
**FLORA LAKE TERMINAL STATION**  
**315KV TO BLOOM LAKE**  
**CAP BANK ON 230KV**

SYS PLAN:	SHEET 1 OF 1
SYS OP:	DATE: OCT 9, 2018
ELEC:	DRAWN BY: JPF
P&C:	REVISION: 0
FILE:	ALTERNATIVE 8 - RLKTS.SXF



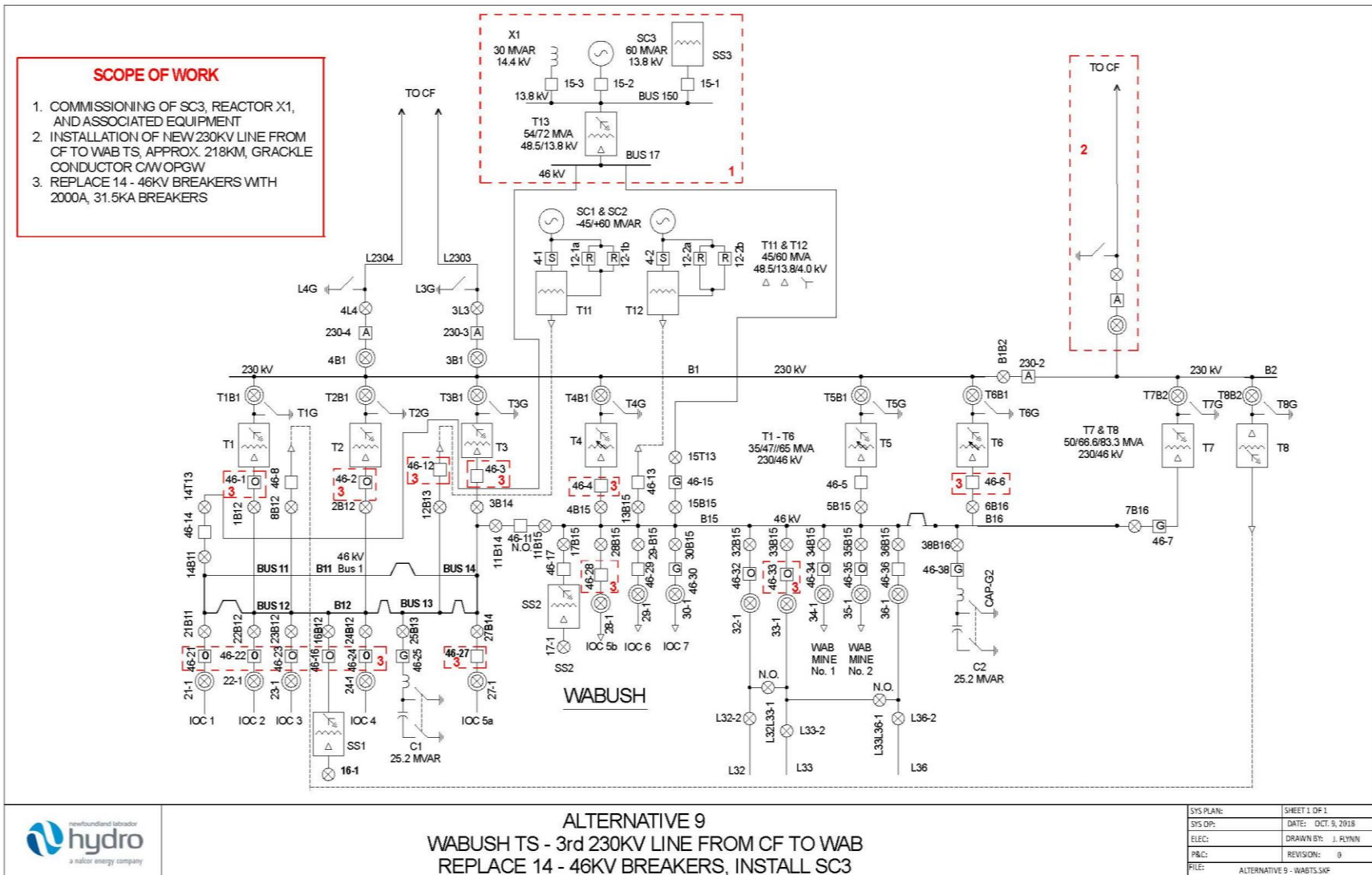

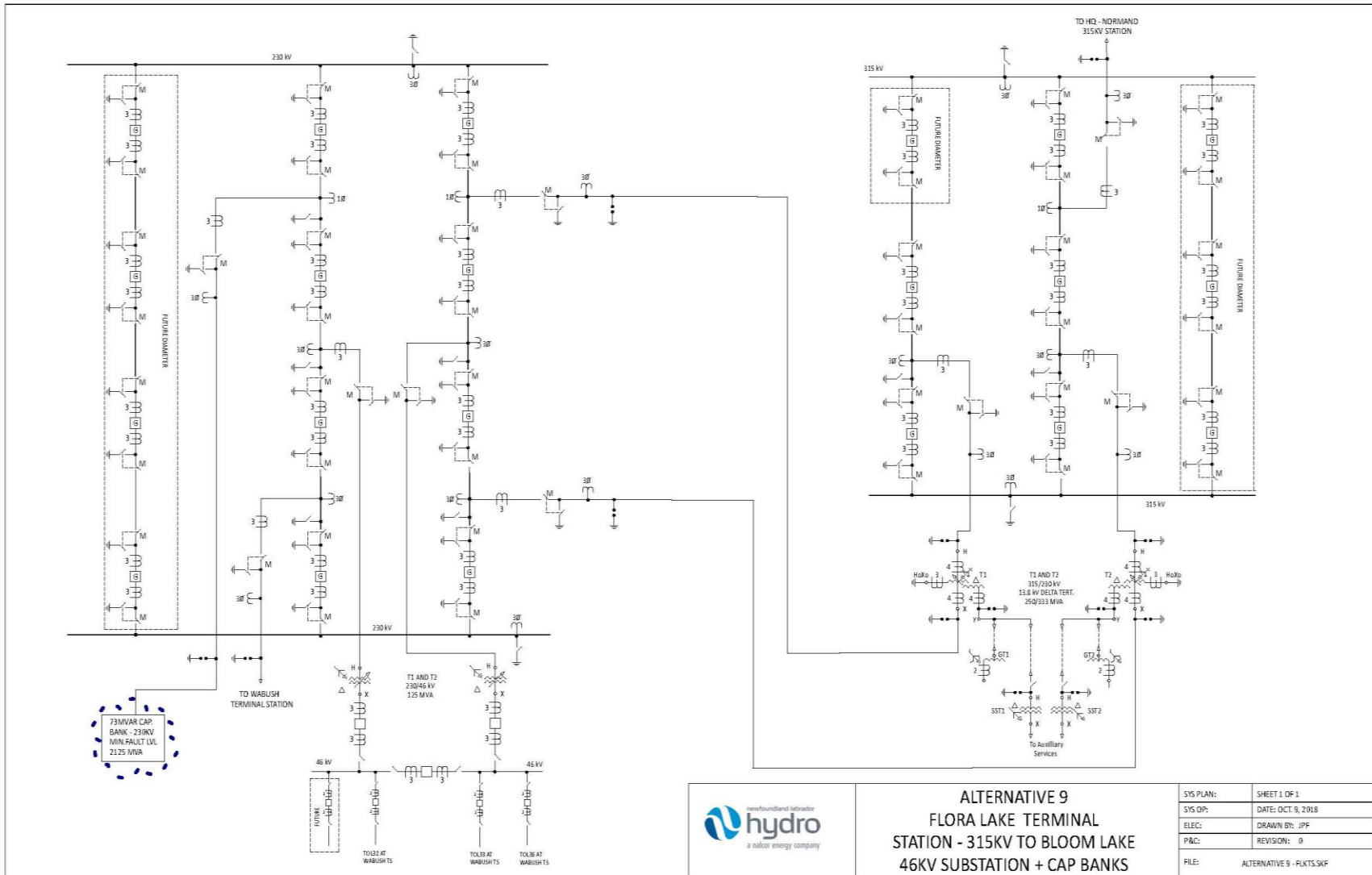

**ALTERNATIVE 9  
 FLORA LAKE TERMINAL  
 STATION - 315KV TO BLOOM LAKE  
 46KV SUBSTATION + CAP BANKS**

SYS PLAN:	SHEET 1 OF 1
SYS OP:	DATE: OCT. 9, 2018
ELEC:	DRAWN BY: JPF
P&C:	REVISION: 0
FILE:	ALTERNATIVE 9 - FLKTS.SKP

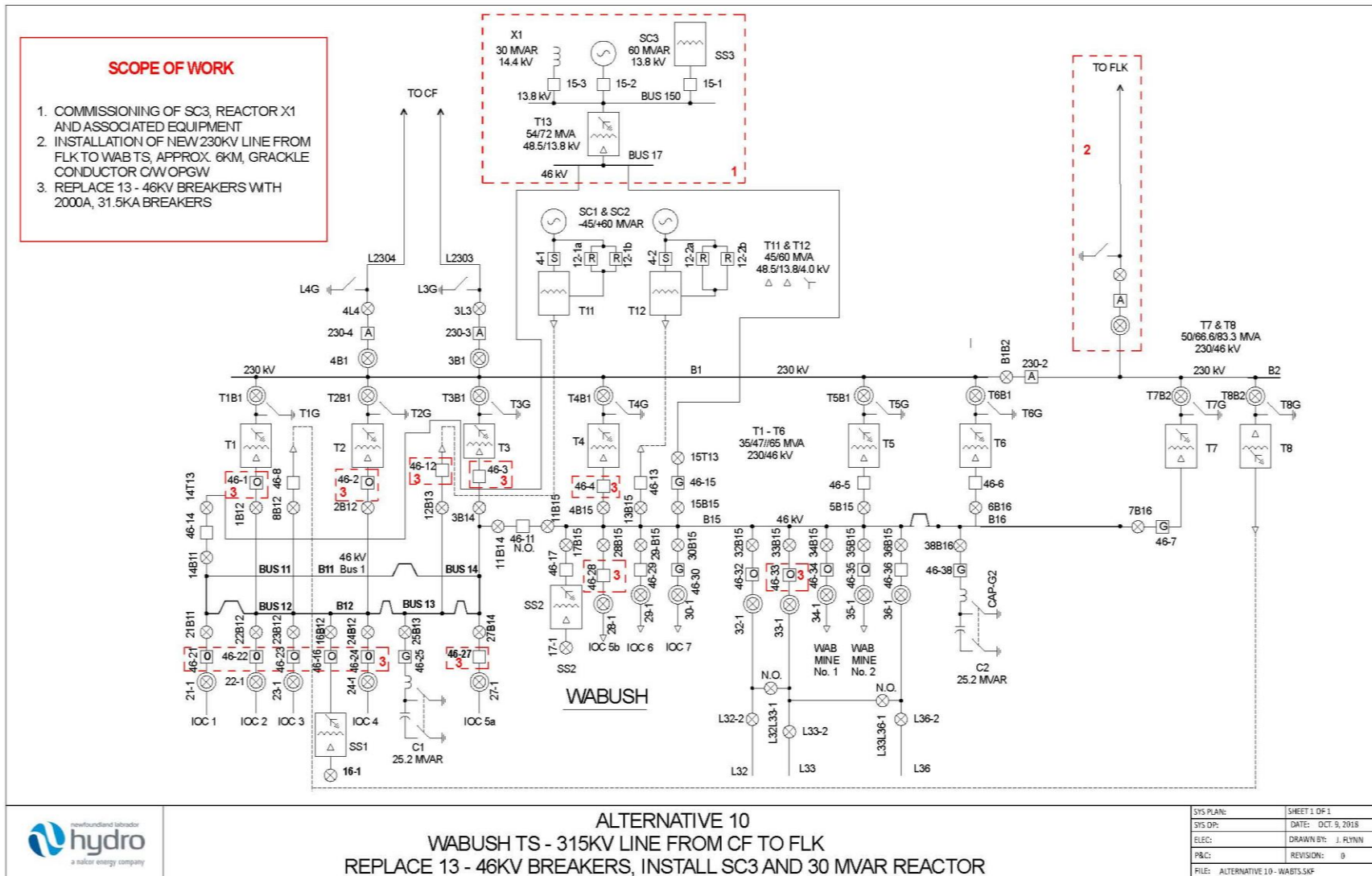

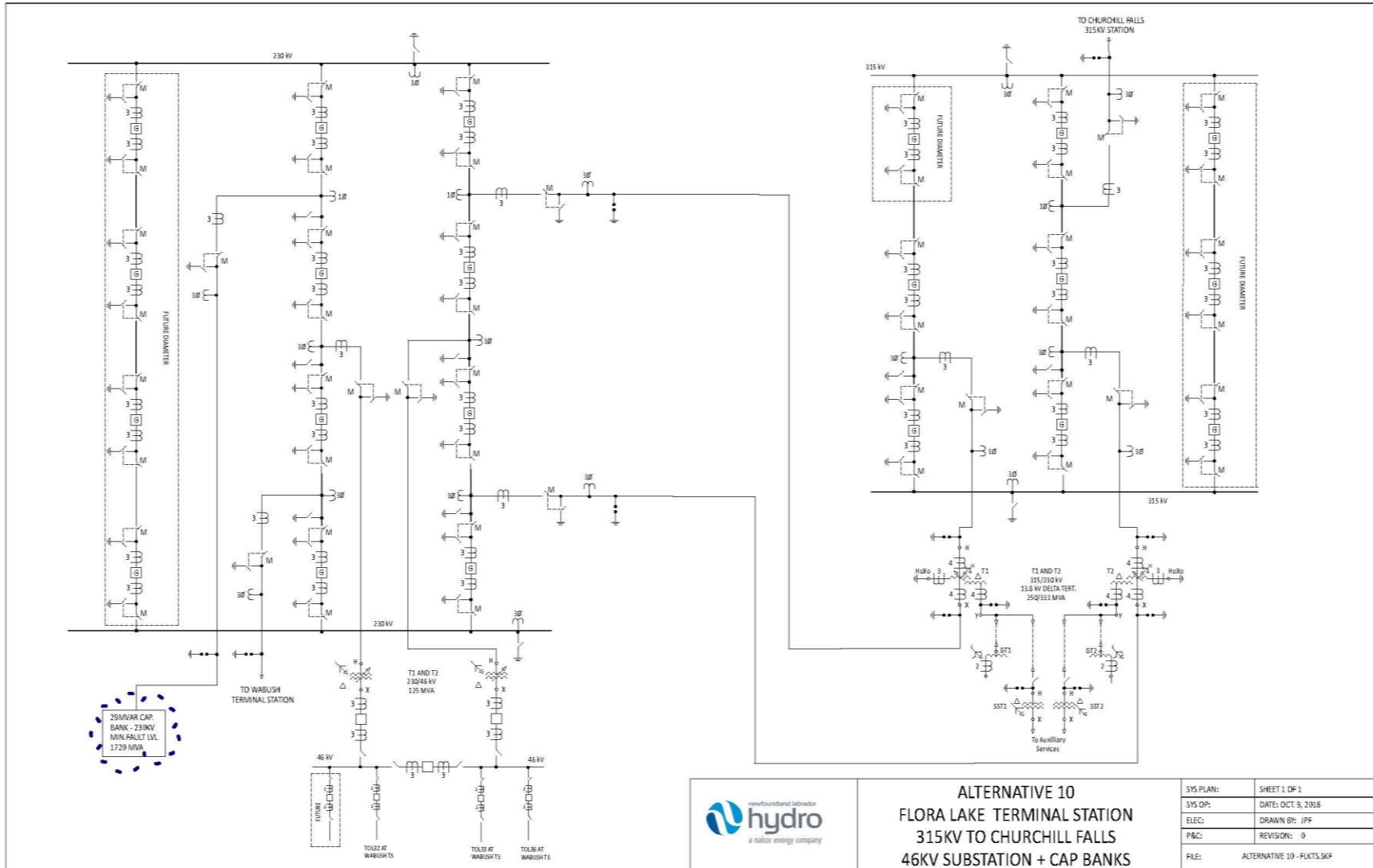

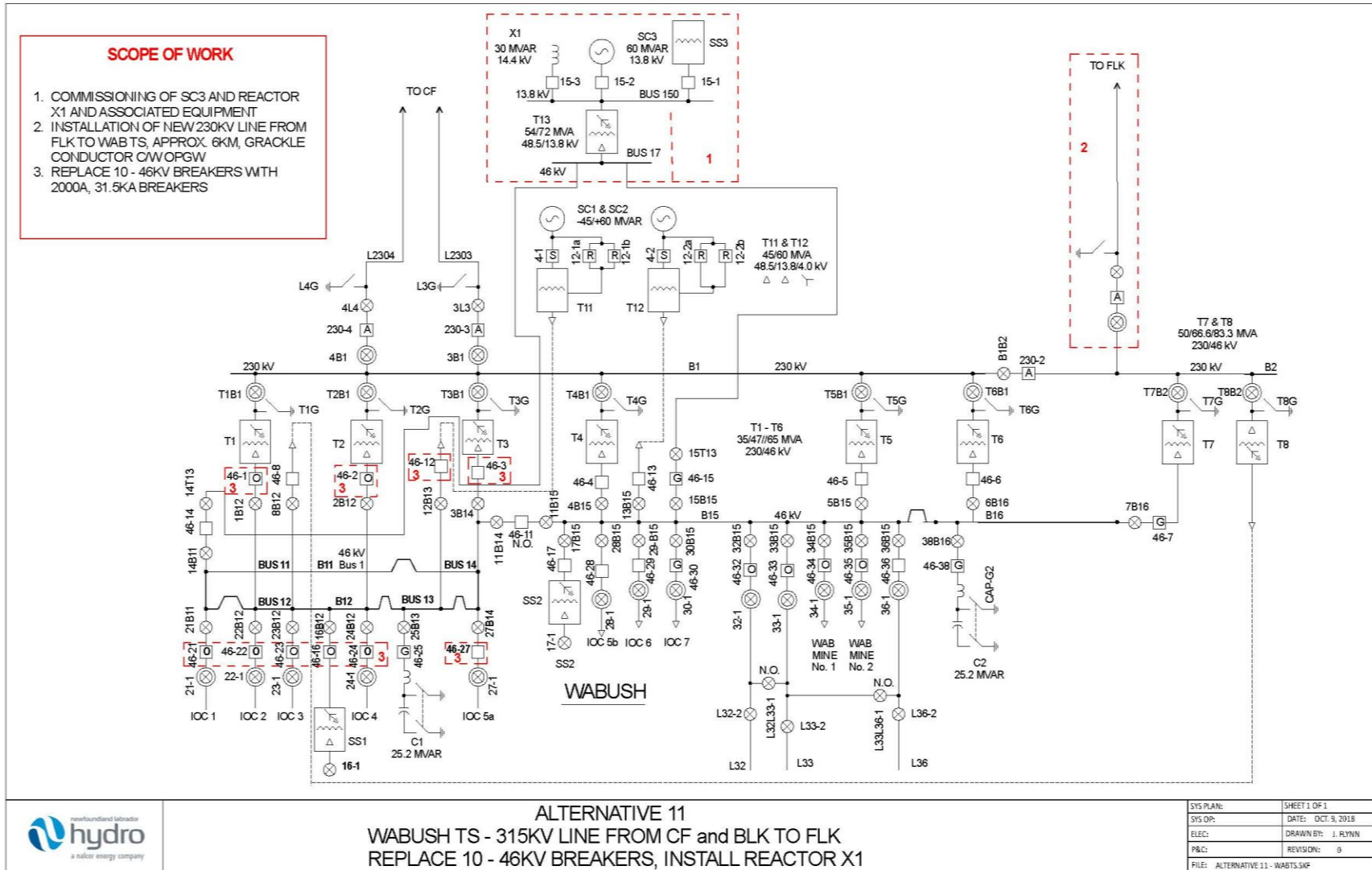



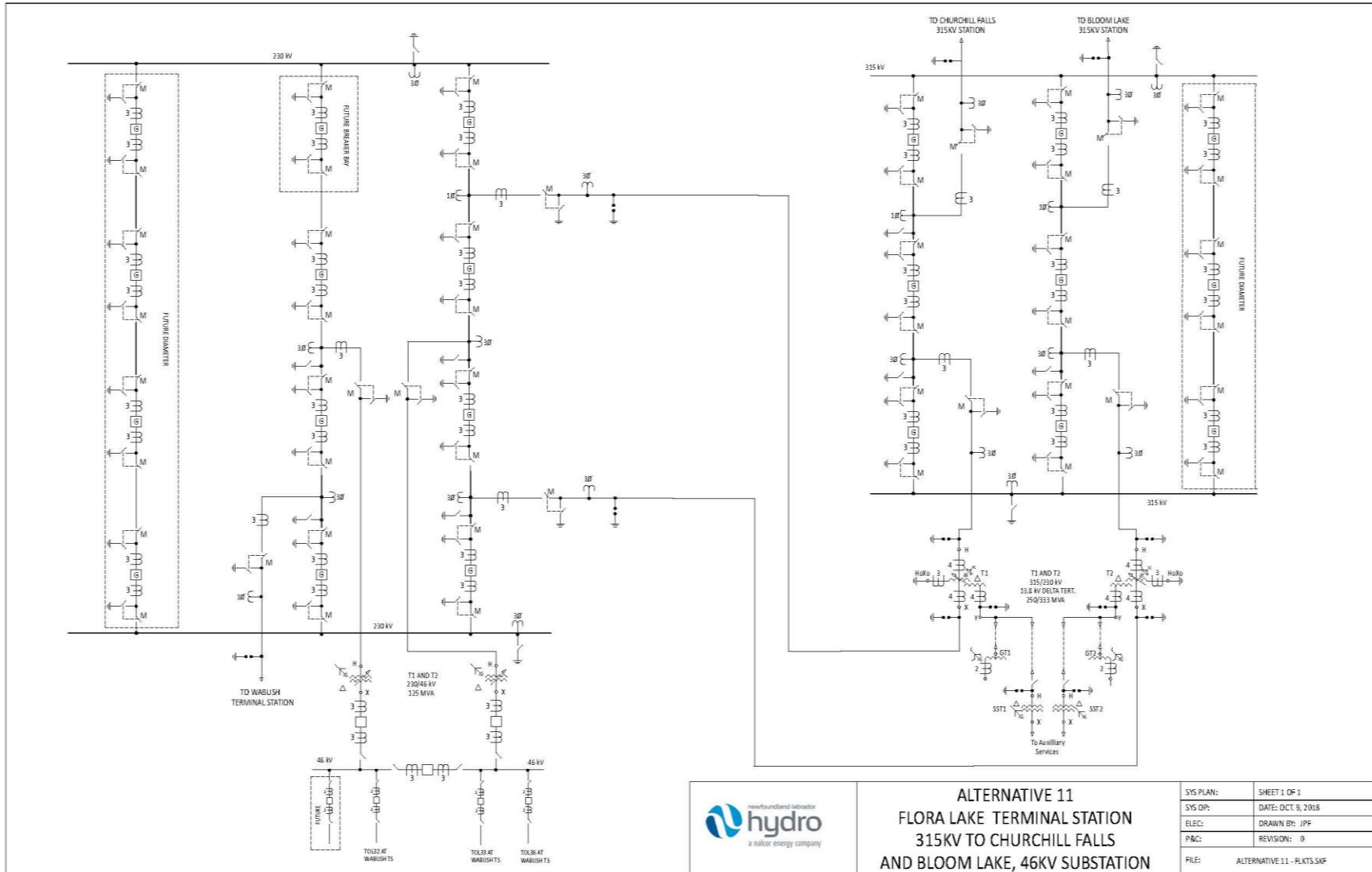

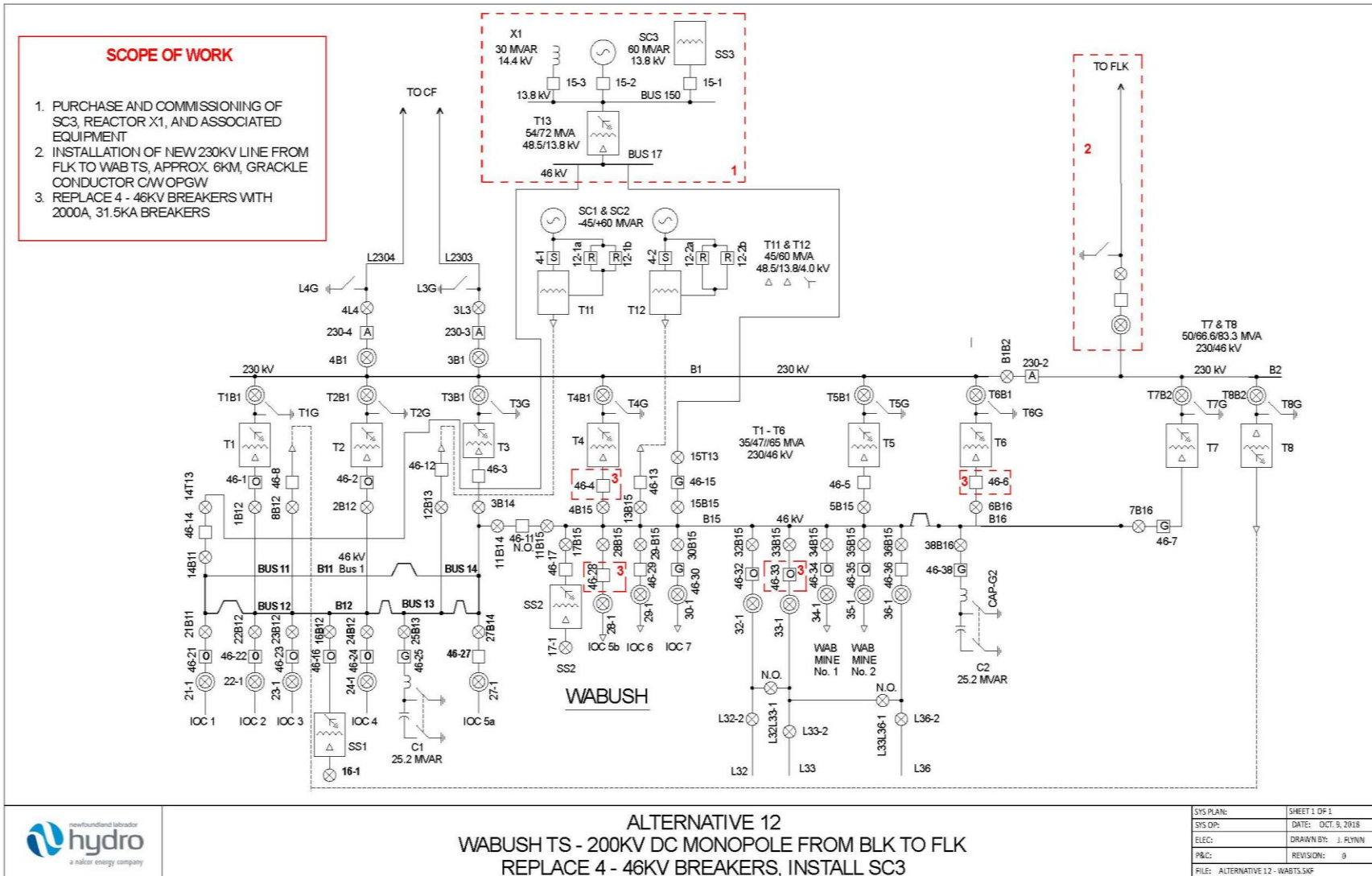

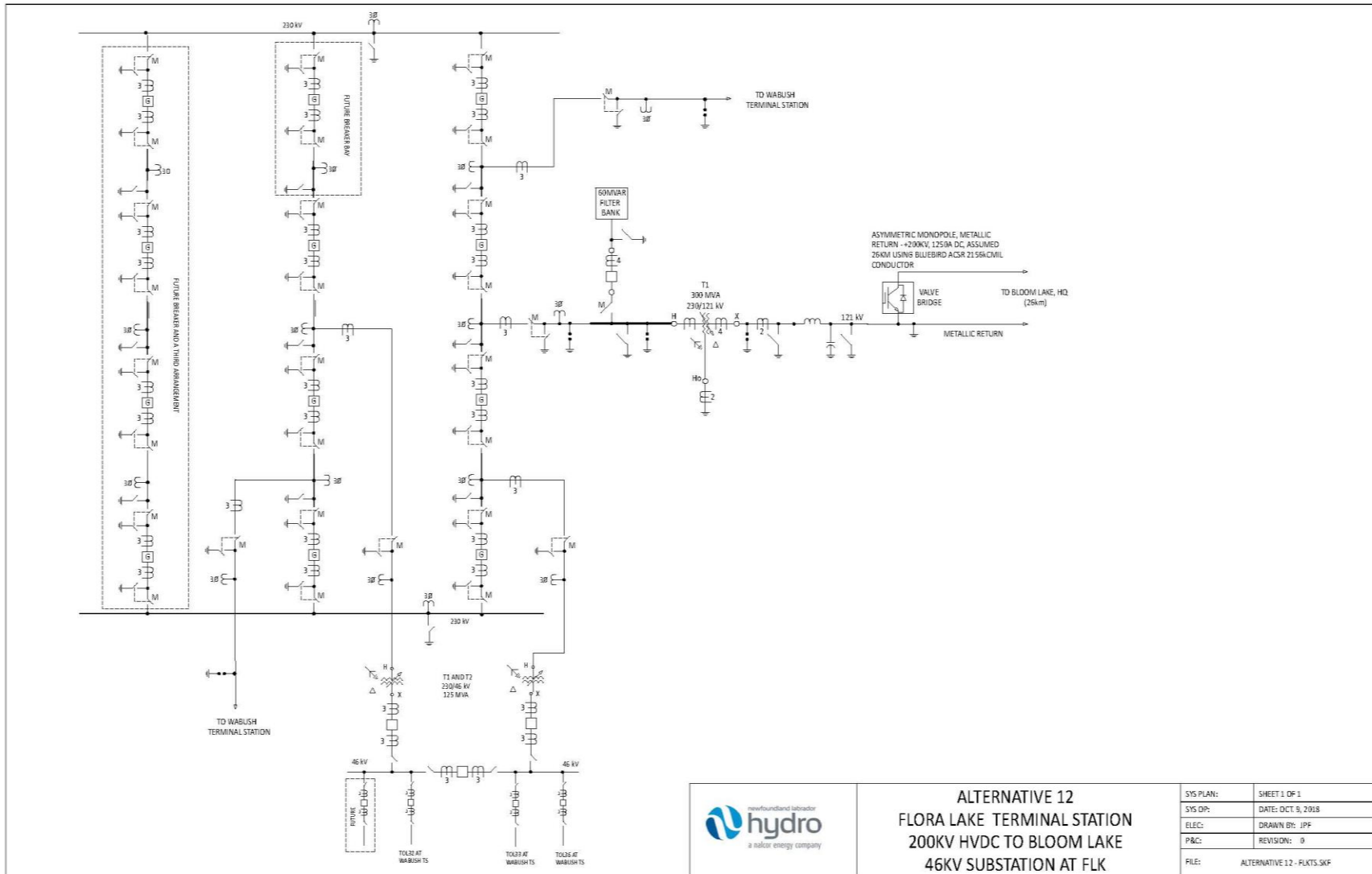



 a nelson energy company	<b>ALTERNATIVE 12</b> <b>FLORA LAKE TERMINAL STATION</b> <b>200KV HVDC TO BLOOM LAKE</b> <b>46KV SUBSTATION AT FLK</b>		SYS PLAN:	SHEET 1 OF 1
			SYS OP:	DATE: OCT. 9, 2015
			ELEC:	DRAWN BY: JPF
			P&C:	REVISION: 0
		FILE:	ALTERNATIVE 12 - FLKTS.SKF	



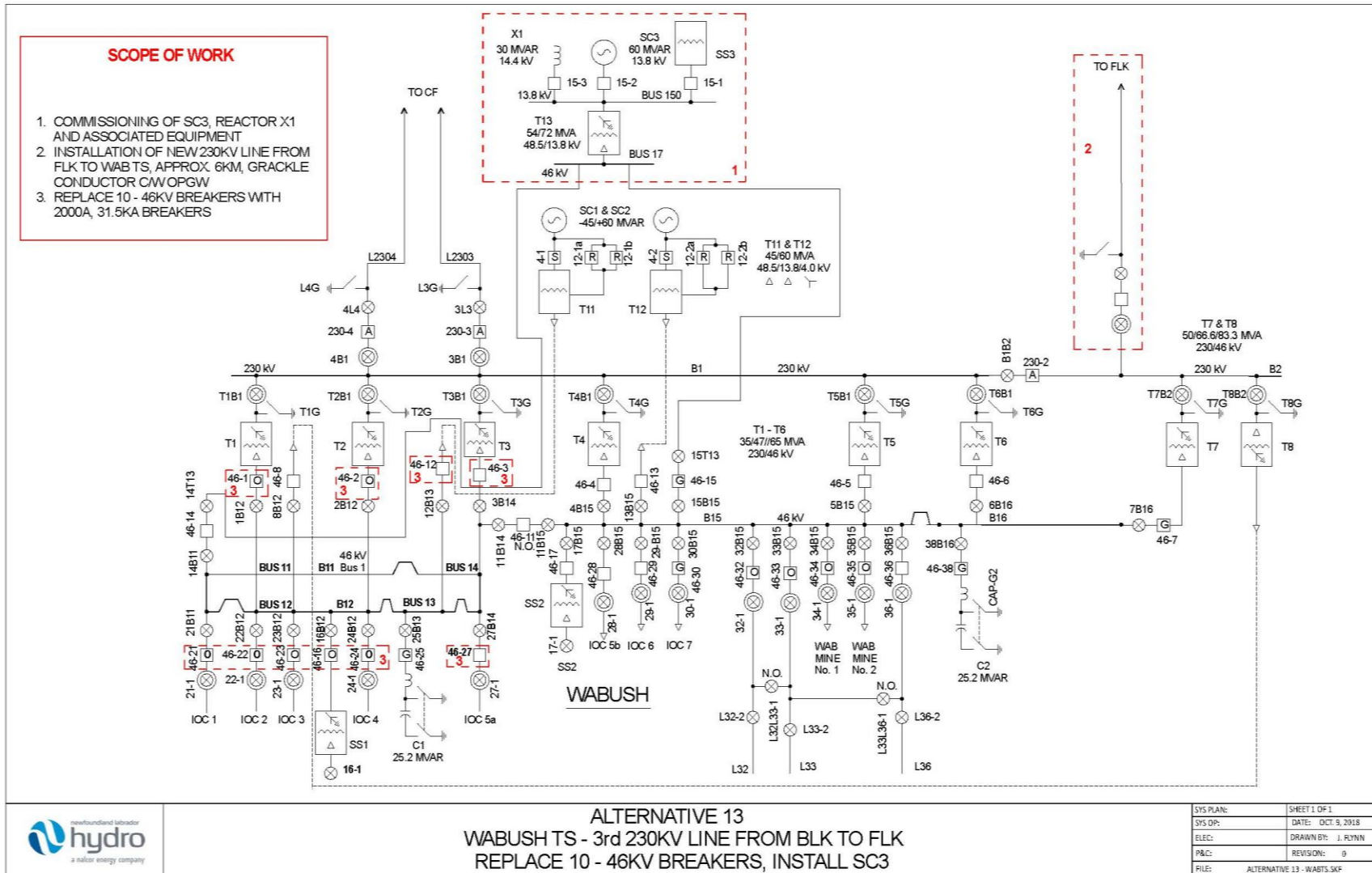

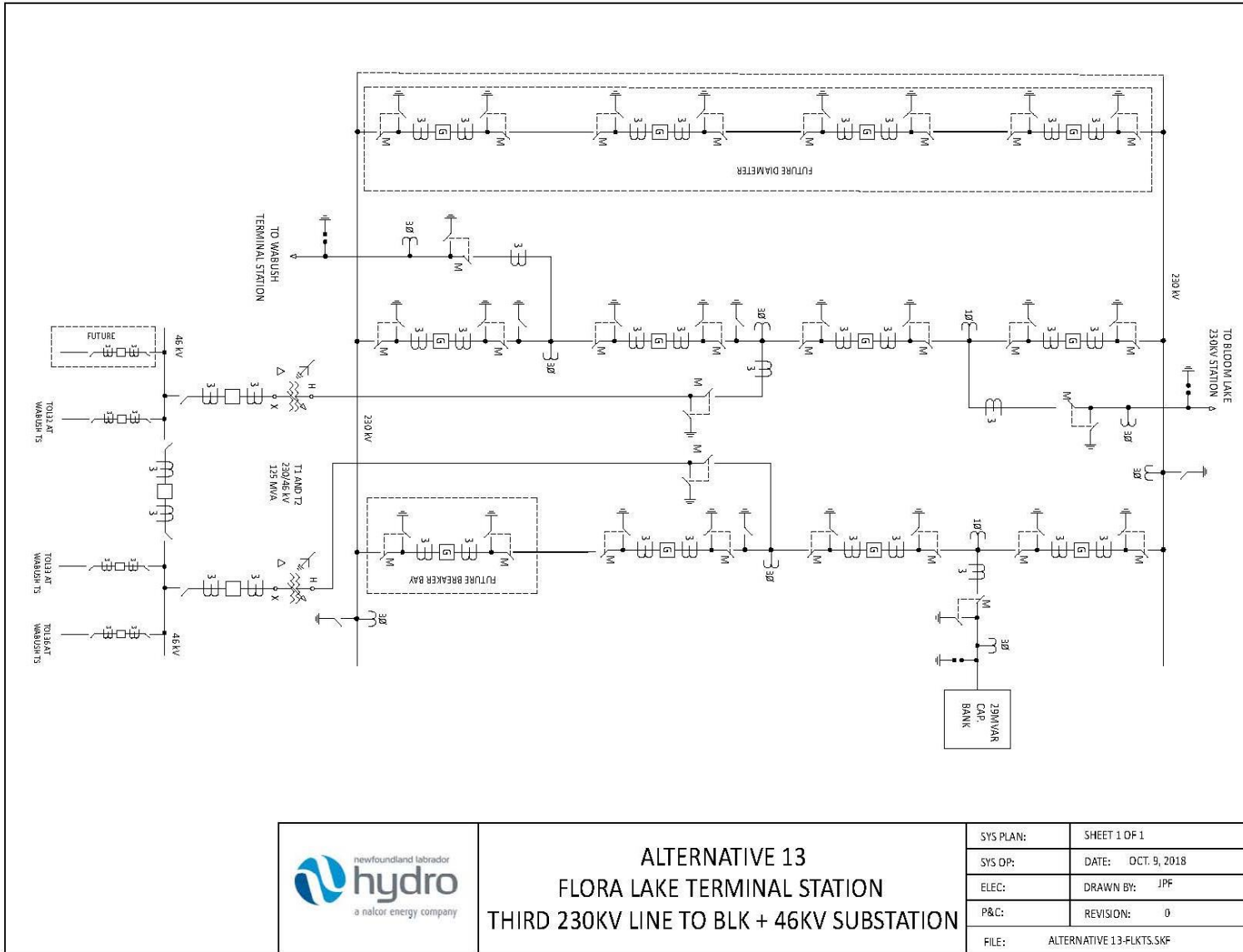

**ALTERNATIVE 13**  
**FLORA LAKE TERMINAL STATION**  
**THIRD 230KV LINE TO BLK + 46KV SUBSTATION**

SYS PLAN:	SHEET 1 OF 1
SYS OP:	DATE: OCT. 9, 2018
ELEC:	DRAWN BY: JPF
P&C:	REVISION: 0
FILE:	ALTERNATIVE 13-FLKTS.SKF

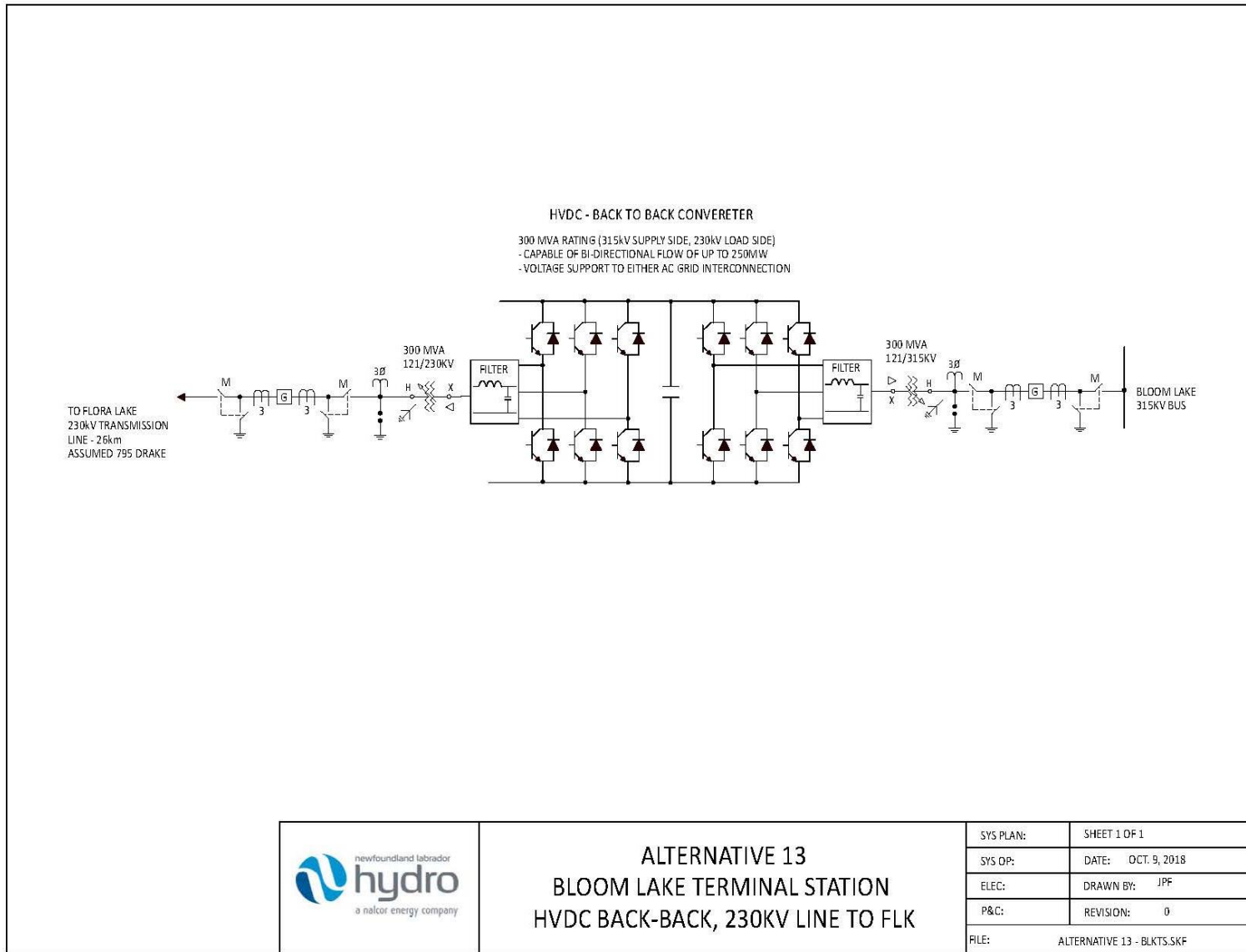

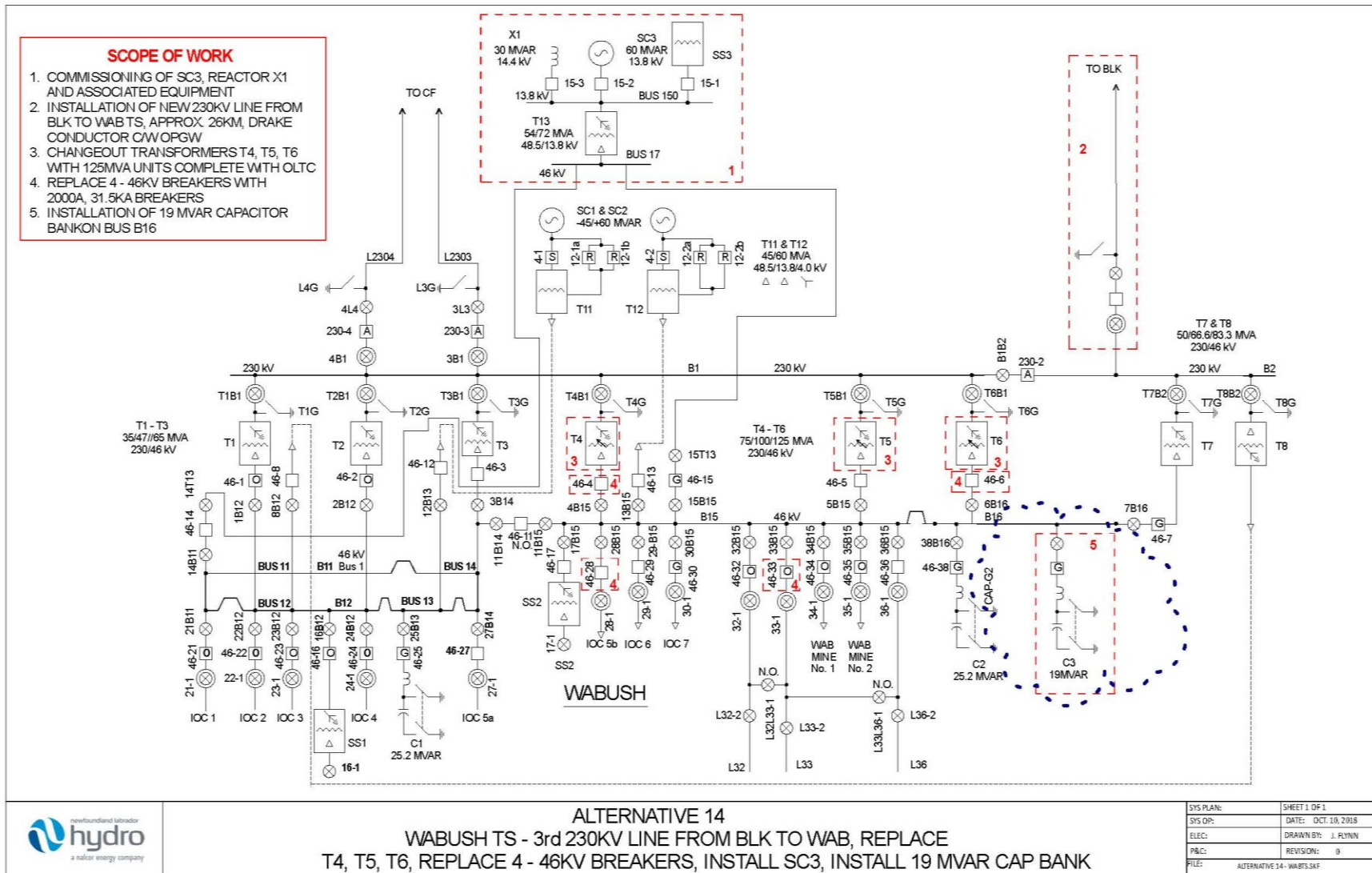

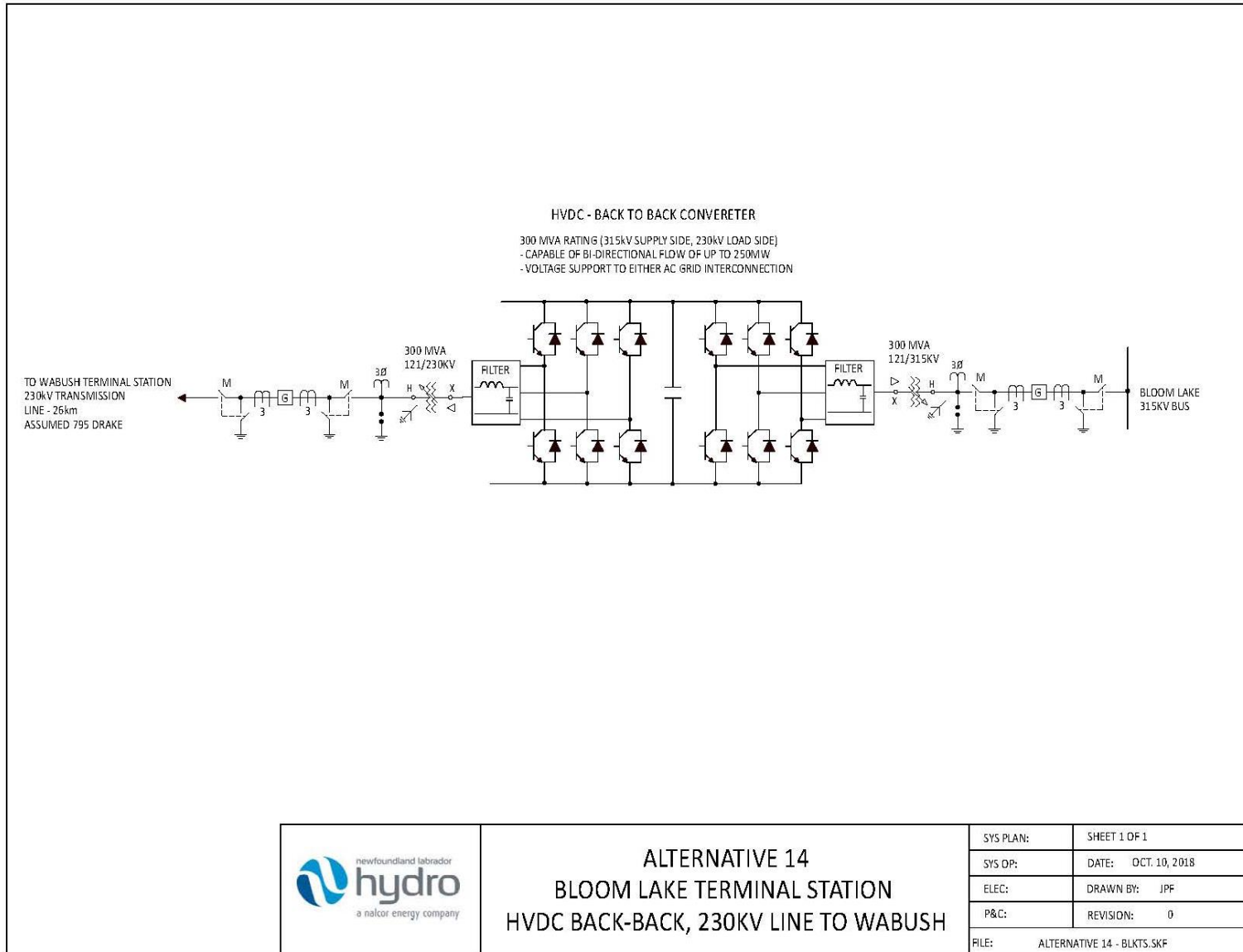

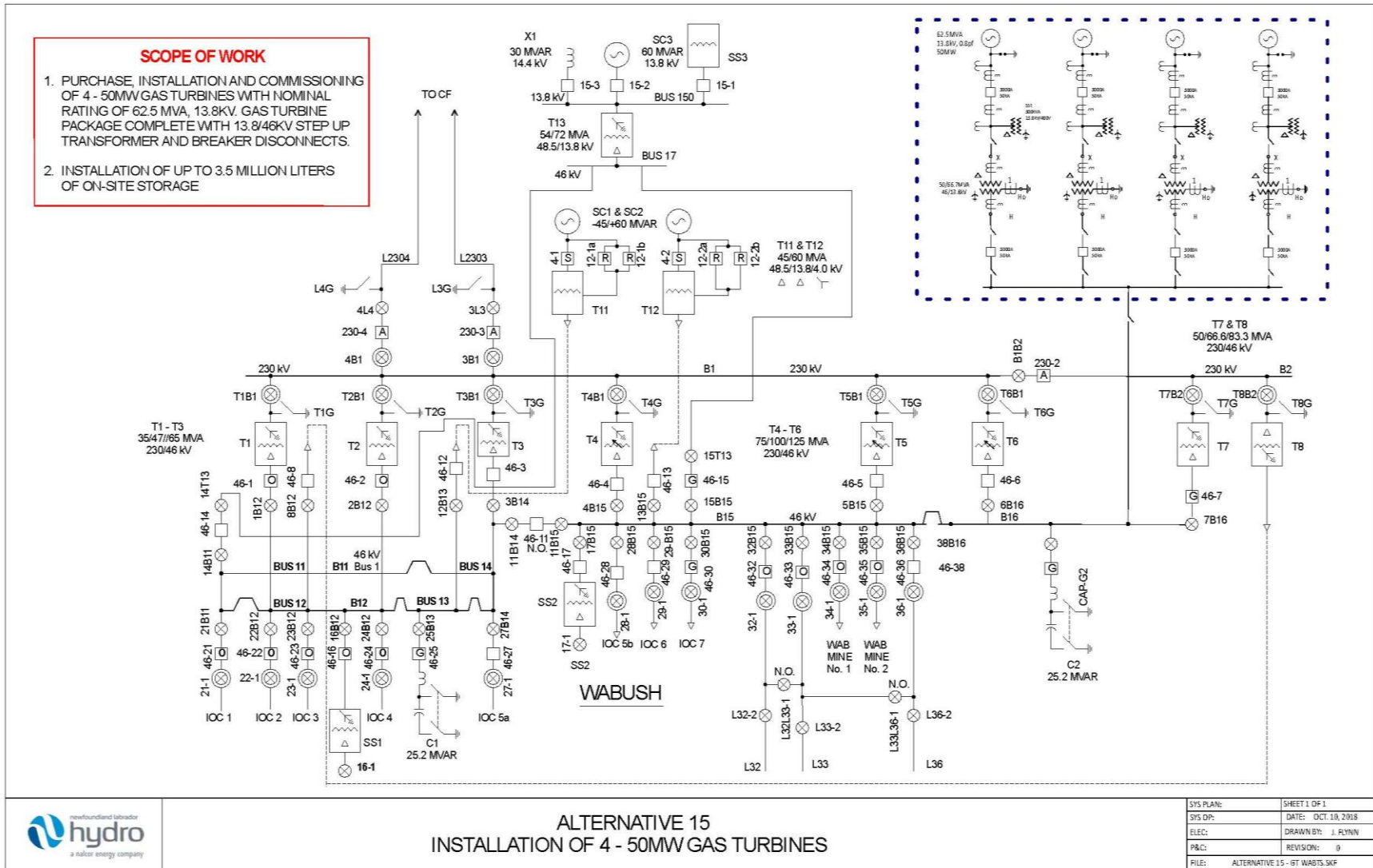





## **Appendix C**

### Labrador West Transmission Loss Analysis



**Forecasted Incremental Change in Losses Compared to Alternative 5 (GWh) - Low Incremental Load Scenario**

Year	Alt. 5	Alt. 6	Alt. 7	Alt. 8	Alt. 9	Alt. 10	Alt. 11	Alt. 12	Alt. 13	Alt. 14
2022	-	90.7	90.7	-21.5	-16.4	112.6	40.0	66.3	66.3	66.3
2023	-	90.9	90.9	-21.4	-16.3	112.8	40.2	66.4	66.4	66.4
2024	-	91.1	91.1	-21.2	-16.1	113.0	40.4	66.6	66.6	66.6
2025	-	91.2	91.2	-21.1	-16.0	113.2	40.6	66.7	66.7	66.7
2026	-	91.4	91.4	-20.9	-15.8	113.4	40.7	66.9	66.9	66.9
2027	-	91.5	91.5	-20.8	-15.7	113.6	40.9	67.0	67.0	67.0
2028	-	91.7	91.7	-20.6	-15.6	113.8	41.1	67.2	67.2	67.2
2029	-	91.8	91.8	-20.5	-15.5	113.9	41.2	67.3	67.3	67.3
2030	-	91.9	91.9	-20.4	-15.3	114.1	41.5	67.4	67.4	67.4
2031	-	92.1	92.1	-20.3	-15.1	114.3	41.7	67.6	67.6	67.6
2032	-	92.2	92.2	-20.2	-15.1	114.4	41.8	67.7	67.7	67.7
2033	-	92.3	92.3	-20.1	-15.0	114.5	41.9	67.8	67.8	67.8
2034	-	92.4	92.4	-19.9	-14.8	114.8	42.1	68.0	68.0	68.0
2035	-	92.5	92.5	-19.8	-14.7	114.9	42.2	68.0	68.0	68.0
2036	-	92.7	92.7	-19.7	-14.6	115.1	42.5	68.2	68.2	68.2
2037	-	92.8	92.8	-19.6	-14.5	115.2	42.6	68.3	68.3	68.3
2038	-	92.9	92.9	-19.4	-14.3	115.4	42.8	68.5	68.5	68.5
2039	-	93.1	93.1	-19.3	-14.2	115.5	42.9	68.6	68.6	68.6
2040	-	93.2	93.2	-19.2	-14.0	115.8	43.1	68.7	68.7	68.7
2041	-	93.3	93.3	-19.1	-14.0	115.9	43.2	68.8	68.8	68.8
2042	-	93.5	93.5	-19.0	-13.8	116.1	43.4	69.0	69.0	69.0
2043	-	93.6	93.6	-18.9	-13.7	116.2	43.6	69.1	69.1	69.1

**Forecasted Benefit of Loss Savings Compared to Alternative 5 (\$) - Low Incremental Load Scenario**

Year	Alt. 5	Alt. 6	Alt. 7	Alt. 8	Alt. 9	Alt. 10	Alt. 11	Alt. 12	Alt. 13	Alt. 14
2022	-	3,176,164	3,176,164	-752,681	-574,273	3,940,263	1,399,370	2,319,978	2,319,978	2,319,978
2023	-	3,181,507	3,181,507	-747,683	-569,298	3,947,090	1,406,080	2,325,172	2,325,172	2,325,172
2024	-	3,186,855	3,186,855	-742,680	-564,318	3,953,924	1,412,796	2,330,371	2,330,371	2,330,371
2025	-	3,192,208	3,192,208	-737,670	-559,331	3,960,763	1,419,519	2,335,574	2,335,574	2,335,574
2026	-	3,197,565	3,197,565	-732,654	-554,339	3,967,609	1,426,250	2,340,783	2,340,783	2,340,783
2027	-	3,202,928	3,202,928	-727,633	-549,340	3,974,460	1,432,987	2,345,996	2,345,996	2,345,996
2028	-	3,208,294	3,208,294	-722,605	-544,336	3,981,318	1,439,731	2,351,214	2,351,214	2,351,214
2029	-	3,211,875	3,211,875	-719,250	-541,734	3,985,403	1,443,726	2,353,987	2,353,987	2,353,987
2030	-	3,217,250	3,217,250	-714,212	-535,614	3,993,006	1,451,239	2,360,276	2,360,276	2,360,276
2031	-	3,222,630	3,222,630	-709,168	-529,487	4,000,615	1,458,760	2,366,572	2,366,572	2,366,572
2032	-	3,226,219	3,226,219	-705,802	-526,875	4,004,711	1,462,767	2,369,352	2,369,352	2,369,352
2033	-	3,229,810	3,229,810	-702,434	-524,260	4,008,808	1,466,777	2,372,134	2,372,134	2,372,134
2034	-	3,235,201	3,235,201	-697,376	-518,118	4,016,433	1,474,315	2,378,442	2,378,442	2,378,442
2035	-	3,238,798	3,238,798	-694,000	-515,498	4,020,537	1,478,332	2,381,229	2,381,229	2,381,229
2036	-	3,244,197	3,244,197	-688,932	-509,345	4,028,172	1,485,882	2,387,546	2,387,546	2,387,546
2037	-	3,247,799	3,247,799	-685,551	-506,718	4,032,282	1,489,906	2,390,338	2,390,338	2,390,338
2038	-	3,253,205	3,253,205	-680,473	-500,555	4,039,929	1,497,468	2,396,665	2,396,665	2,396,665
2039	-	3,256,813	3,256,813	-677,084	-497,922	4,044,045	1,501,501	2,399,461	2,399,461	2,399,461
2040	-	3,262,227	3,262,227	-671,996	-491,748	4,051,703	1,509,075	2,405,797	2,405,797	2,405,797
2041	-	3,265,840	3,265,840	-668,601	-489,109	4,055,825	1,513,114	2,408,598	2,408,598	2,408,598
2042	-	3,271,263	3,271,263	-663,503	-482,924	4,063,493	1,520,700	2,414,943	2,414,943	2,414,943
2043	-	3,274,881	3,274,881	-660,100	-480,279	4,067,622	1,524,748	2,417,749	2,417,749	2,417,749

**Forecasted Losses Based on Load Flow Analysis (GWh) – High Incremental Load Scenario**

<b>Year</b>	<b>Alt. 5</b>	<b>Alt. 6</b>	<b>Alt. 7</b>	<b>Alt. 8</b>	<b>Alt. 9</b>	<b>Alt. 10</b>	<b>Alt. 11</b>	<b>Alt. 12</b>	<b>Alt. 13</b>	<b>Alt. 14</b>
2022	271.0	144.0	144.0	257.5	252.6	112.1	184.8	169.3	169.3	169.3
2023	271.3	144.1	144.1	257.7	252.8	112.2	184.9	169.5	169.5	169.5
2024	271.7	144.2	144.2	257.8	252.9	112.3	185.0	169.7	169.7	169.7
2025	272.0	144.4	144.4	257.9	253.1	112.4	185.1	169.9	169.9	169.9
2026	272.4	144.5	144.5	258.1	253.2	112.5	185.2	170.0	170.0	170.0
2027	272.7	144.6	144.6	258.2	253.3	112.6	185.3	170.2	170.2	170.2
2028	273.1	144.8	144.8	258.3	253.5	112.7	185.4	170.4	170.4	170.4
2029	273.3	144.9	144.9	258.5	253.6	112.8	185.5	170.5	170.5	170.5
2030	273.7	145.0	145.0	258.6	253.8	112.9	185.6	170.7	170.7	170.7
2031	274.0	145.2	145.2	258.8	253.9	113.0	185.7	170.8	170.8	170.8
2032	274.3	145.3	145.3	258.9	254.0	113.1	185.8	170.9	170.9	170.9
2033	274.5	145.4	145.4	259.0	254.2	113.2	185.9	171.1	171.1	171.1
2034	274.9	145.5	145.5	259.2	254.3	113.3	186.0	171.2	171.2	171.2
2035	275.1	145.7	145.7	259.3	254.4	113.4	186.0	171.4	171.4	171.4
2036	275.4	145.8	145.8	259.4	254.6	113.5	186.1	171.5	171.5	171.5
2037	275.7	145.9	145.9	259.6	254.7	113.6	186.2	171.6	171.6	171.6
2038	276.0	146.0	146.0	259.7	254.9	113.7	186.3	171.8	171.8	171.8
2039	276.3	146.2	146.2	259.9	255.0	113.8	186.4	171.9	171.9	171.9
2040	276.6	146.3	146.3	260.0	255.1	113.8	186.5	172.1	172.1	172.1
2041	276.9	146.4	146.4	260.1	255.3	113.9	186.6	172.2	172.2	172.2
2042	277.2	146.6	146.6	260.3	255.4	114.0	186.7	172.3	172.3	172.3
2043	277.5	146.7	146.7	260.4	255.6	114.1	186.8	172.5	172.5	172.5

**Forecasted Incremental Change in Losses Compared to Alternative 5 (GWh) - High Incremental Load Scenario**

<b>Year</b>	<b>Alt. 5</b>	<b>Alt. 6</b>	<b>Alt. 7</b>	<b>Alt. 8</b>	<b>Alt. 9</b>	<b>Alt. 10</b>	<b>Alt. 11</b>	<b>Alt. 12</b>	<b>Alt. 13</b>	<b>Alt. 14</b>
2022	-	127.0	127.0	13.5	18.3	158.9	86.2	101.6	101.6	101.6
2023	-	127.2	127.2	13.7	18.5	159.1	86.4	101.8	101.8	101.8
2024	-	127.4	127.4	13.9	18.8	159.4	86.7	102.0	102.0	102.0
2025	-	127.7	127.7	14.1	19.0	159.6	86.9	102.2	102.2	102.2
2026	-	127.9	127.9	14.3	19.2	159.9	87.2	102.3	102.3	102.3
2027	-	128.1	128.1	14.5	19.4	160.1	87.4	102.5	102.5	102.5
2028	-	128.3	128.3	14.7	19.6	160.4	87.7	102.7	102.7	102.7
2029	-	128.4	128.4	14.8	19.7	160.5	87.8	102.8	102.8	102.8
2030	-	128.6	128.6	15.1	19.9	160.8	88.1	103.0	103.0	103.0
2031	-	128.9	128.9	15.3	20.1	161.0	88.4	103.2	103.2	103.2
2032	-	129.0	129.0	15.4	20.2	161.2	88.5	103.3	103.3	103.3
2033	-	129.1	129.1	15.5	20.3	161.3	88.6	103.4	103.4	103.4
2034	-	129.3	129.3	15.7	20.5	161.6	88.9	103.6	103.6	103.6
2035	-	129.4	129.4	15.8	20.6	161.7	89.0	103.7	103.7	103.7
2036	-	129.7	129.7	16.0	20.9	162.0	89.3	103.9	103.9	103.9
2037	-	129.8	129.8	16.1	21.0	162.1	89.5	104.0	104.0	104.0
2038	-	130.0	130.0	16.3	21.2	162.4	89.7	104.3	104.3	104.3
2039	-	130.1	130.1	16.4	21.3	162.5	89.9	104.3	104.3	104.3
2040	-	130.3	130.3	16.6	21.5	162.8	90.1	104.6	104.6	104.6
2041	-	130.4	130.4	16.7	21.6	162.9	90.3	104.7	104.7	104.7
2042	-	130.7	130.7	16.9	21.8	163.2	90.5	104.9	104.9	104.9
2043	-	130.8	130.8	17.0	21.9	163.3	90.7	105.0	105.0	105.0

**Forecasted Benefit of Loss Savings Compared to Alternative 5 (\$) - High Incremental Load Scenario**

Year	Alt. 5	Alt. 6	Alt. 7	Alt. 8	Alt. 9	Alt. 10	Alt. 11	Alt. 12	Alt. 13	Alt. 14
2022	-	4,445,585	4,445,585	470,892	641,591	5,559,867	3,015,266	3,557,055	3,557,055	3,557,055
2023	-	4,453,150	4,453,150	478,395	649,056	5,568,831	3,024,297	3,563,285	3,563,285	3,563,285
2024	-	4,460,720	4,460,720	485,905	656,528	5,577,802	3,033,337	3,569,520	3,569,520	3,569,520
2025	-	4,468,297	4,468,297	493,422	664,006	5,586,780	3,042,383	3,575,759	3,575,759	3,575,759
2026	-	4,475,880	4,475,880	500,946	671,491	5,595,765	3,051,437	3,582,003	3,582,003	3,582,003
2027	-	4,483,469	4,483,469	508,477	678,983	5,604,756	3,060,499	3,588,252	3,588,252	3,588,252
2028	-	4,491,064	4,491,064	516,015	686,482	5,613,754	3,069,568	3,594,506	3,594,506	3,594,506
2029	-	4,494,546	4,494,546	519,440	689,868	5,618,640	3,074,525	3,597,865	3,597,865	3,597,865
2030	-	4,502,151	4,502,151	526,989	697,377	5,627,649	3,083,606	3,605,346	3,605,346	3,605,346
2031	-	4,509,761	4,509,761	534,545	704,894	5,636,666	3,092,695	3,612,834	3,612,834	3,612,834
2032	-	4,514,045	4,514,045	537,981	708,290	5,641,562	3,097,665	3,616,201	3,616,201	3,616,201
2033	-	4,518,331	4,518,331	541,419	711,689	5,646,460	3,102,637	3,619,569	3,619,569	3,619,569
2034	-	4,525,955	4,525,955	548,989	719,220	5,655,492	3,111,742	3,627,069	3,627,069	3,627,069
2035	-	4,530,246	4,530,246	552,434	722,625	5,660,396	3,116,722	3,630,442	3,630,442	3,630,442
2036	-	4,537,880	4,537,880	560,015	730,167	5,669,438	3,125,840	3,637,951	3,637,951	3,637,951
2037	-	4,542,177	4,542,177	563,466	733,578	5,674,350	3,130,827	3,641,329	3,641,329	3,641,329
2038	-	4,549,821	4,549,821	571,058	741,130	5,683,402	3,139,957	3,648,848	3,648,848	3,648,848
2039	-	4,554,124	4,554,124	574,515	744,547	5,688,320	3,144,951	3,652,230	3,652,230	3,652,230
2040	-	4,561,777	4,561,777	582,119	752,111	5,697,384	3,154,093	3,659,758	3,659,758	3,659,758
2041	-	4,565,289	4,565,289	585,582	755,534	5,702,307	3,159,095	3,663,145	3,663,145	3,663,145
2042	-	4,572,952	4,572,952	593,196	763,108	5,711,382	3,168,249	3,670,683	3,670,683	3,670,683
2043	-	4,576,469	4,576,469	596,666	766,538	5,716,312	3,173,259	3,674,075	3,674,075	3,674,075

## **Appendix D**

### Operating and Maintenance Assumptions for Alternatives

1	<b>Alternatives 1 to 5</b>	No appreciable incremental cost
2		
3	<b>Alternative 6</b>	215 km of 230kV @ \$4,611 / km = \$ 991,365
4		
5	<b>Alternative 7</b>	215 km of 230kV @ \$4,611 / km = \$ 991,365
6		
7	<b>Alternative 8</b>	5 km of 230kV @ \$4,611 / km = \$ 23,055
8		50 km of 315kV @ \$5,489 / km = \$ 274,450
9		315kV Terminal Station @ \$4,060 per MW × 328 MW = \$1,331,680
10		Total = \$ 1,629,185
11		
12	<b>Alternative 9</b>	5 km of 230kV @ \$4,611 / km = \$ 23,055
13		50 km of 315kV @ \$5,489 / km = \$ 274,450
14		315kV Terminal Station @ \$4,060 per MW × 328 MW = \$1,331,680
15		Total = \$ 1,629,185
16		
17	<b>Alternative 10</b>	5 km of 230kV @ \$4,611 / km = \$ 23,055
18		210 km of 315kV @ \$5,489 / km X 0.6 = \$ 691,614
19		315kV Terminal Station @ \$4,060 per MW × 328 MW = \$1,331,680
20		Total = \$ 2,046,349
21		
22	<b>Alternative 11</b>	5 km of 230kV @ \$4,611 / km = \$ 23,055
23		50 km of 315kV @ \$5,489 / km = \$ 274,450
24		210 km of 315kV @ \$5,489 / km X 0.6 = \$ 691,614
25		315kV Terminal Station @ \$4,060 per MW × 328 MW X 1.5 = \$1,997,520
26		Total = \$ 2,986,639
27		

---

1	<b>Alternative 12</b>	5 km of 230kV @ \$4,611 per km = \$23,055
2		50 km of Hvdc @ \$5,003 per km = \$250,150
3		Converter @ \$13,228 per MW × 250 MW = \$3,307,000
4		Total = \$3,580,205
5		
6	<b>Alternative 13</b>	55 km of 230kV @ \$4,611 per km = \$253,605
7		Converter @ \$13,228 per MW × 250 MW × ½ = \$1,653,500
8		(back-to-back converter assumed ½ of dc converter)
9		Total = \$1,907,105
10		
11	<b>Alternative 14</b>	55 km of 230 kV @ \$4,611 per km = \$253,605
12		Converter @ \$13,228 per MW × 250 MW × ½ = \$1,653,500
13		(Back to Back converter assumed ½ of dc converter)
14		Total = \$1,907,105
15		
16	<b>Alternative 15</b>	Gas Turbine O&M assumed at 1 percent of capital cost of \$567.44 million
17		Total = \$ 5,674,400
18		
19	<b>Alternative 16</b>	215 km of 230 kV @ \$4,611 per km = \$991,365
20		
21	<b>Alternative 17</b>	5 km of 230 kV @ \$4,611 per km = \$23,055
22		50 km of 315 kV @ \$5,489 per km = \$274,450
23		315 kV terminal station @ \$4,060 per MW × 328 MW = \$1,331,680
24		Total = \$ 1,629,185



## **Appendix E**

### **Voltage and Conductor Selection**

1 **Selection of Transmission Voltage for New Interconnections**

2 Available transmission voltages in Labrador include 66 kV, 138 kV, 230 kV, and 735 kV. The  
 3 315 kV voltage level will be added as part of the Lower Churchill Project and integration of  
 4 Muskrat Falls to Churchill Falls. The transmission line route from Churchill Falls to Labrador  
 5 West area is approximately 215 km in length.

6  
 7 The St. Clair Curve provides transmission line loadability using the surge impedance loading  
 8 (“SIL”) of the line and the line length. For a transmission line on the order of 215 km in length,  
 9 the St. Clair Curve indicates the load limit at approximately 1.6 times its SIL. The table below  
 10 summarizes typical Hydro values of SIL for the available voltage classes and applicability for  
 11 supply to Labrador West.

**Table E1: Churchill Falls to Labrador West  
 Based upon St. Clair Curve 499 MW Transfer Limit – 215 km**

Option	SIL (MW)	Max MW per circuit	Required No. of Circuits
66 kV	13	21	24
138 kV	50	80	7
230 kV (single conductor bundle)	137	219	3
230 kV (two conductor bundle)	194	310	2
315 kV (two conductor bundle)	328	525	1
735 kV (four conductor bundle)	1640	2624	1

12 Based upon the St. Clair curve, voltage regulation and stability margin should be obtainable  
 13 with three single 230 kV transmission line consisting of a single conductor per bundle, which  
 14 would mean construction of one more 230 kV transmission line. Alternatively, a two  
 15 conductor bundle per phase operating at either 230 kV or 315 kV is also expected to provide  
 16 good voltage regulation for the proposed load.

17

18 **Conductor Selection**

19 For the 230 kV transmission lines, it is assumed that 1192.5 kcmil, 54/19, ACSR “GRACKLE” is  
 20 being used. For 315 kV transmission, the interconnection between Churchill Falls and Muskrat

- 1 Falls will utilize a two conductor bundle of 795 kcmil, 26/7, ACSR “DRAKE” conductor. This
- 2 conductor has been determined to provide acceptable corona performance. For the technical
- 3 analysis the 315 kV construction will assume the 2 × 795 kcmil, 26/7, ACSR “DRAKE” bundle.







**Appendix C**

Labrador West 46 kV System Expansion – Wabush Substation Upgrade  
Alternatives





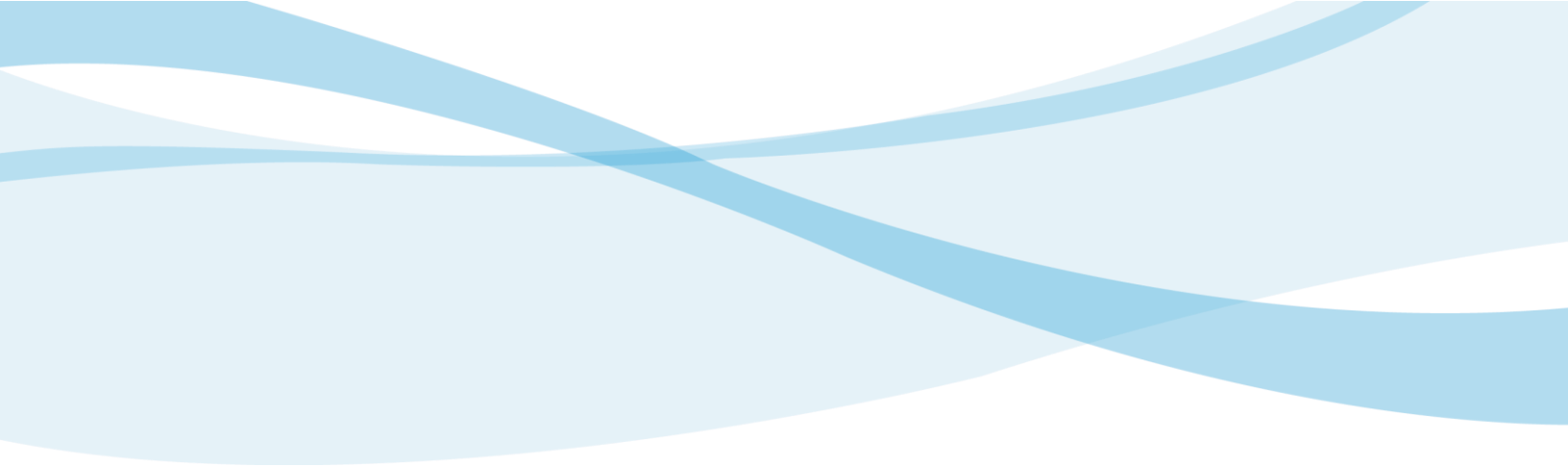

Labrador West 46 kV System Expansion  
Wabush Substation Upgrade Alternatives

October 2018

*A Report to the Board of Commissioners of Public Utilities*



## Table of Contents

1	Introduction .....	1
2	Overview .....	1
	2.1 Existing Electrical Infrastructure in Wabush.....	1
	2.1.1 Wabush Transmission Line L36.....	3
	2.1.2 Wabush Substation.....	3
3	Current Status .....	4
	3.1 Ability to Meet Peak Demand.....	4
	3.2 Reliability Limitations.....	5
	3.3 Load Forecast .....	5
4	Wabush Substation Upgrade Alternatives.....	6
	4.1 Study Assumptions.....	7
	4.2 Description of Alternatives .....	7
5	Economic Analysis of Alternatives .....	8
	5.1 Economic Analysis Assumptions and Exclusions .....	9
	5.2 Budget Estimates .....	9
	5.3 Economic Analysis Summary .....	9
6	Recommendations .....	11

## List of Appendices

Appendix A: Single-Line Diagram

Appendix B: Description of Alternatives

1 **1 Introduction**

2 The purpose of this study is to assess alternatives to meet forecasted load growth at Wabush  
3 Substation and to identify the most economical solution for transformer capacity. The analysis  
4 is based on forecasted load growth period of 25 years from 2018-2019 to 2043-2044.

5  
6 **2 Overview**

7 **2.1 Existing Electrical Infrastructure in Wabush**

8 The electrical infrastructure in Labrador City and Wabush is owned, operated, and maintained  
9 by Hydro. The towns of Wabush and Labrador City are located in western Labrador near the  
10 Quebec border and have a population of approximately 1,900<sup>1</sup> and 8,600<sup>2</sup> people, respectively.

11 Figure 1 is a map of Labrador showing the geographical location of the towns.

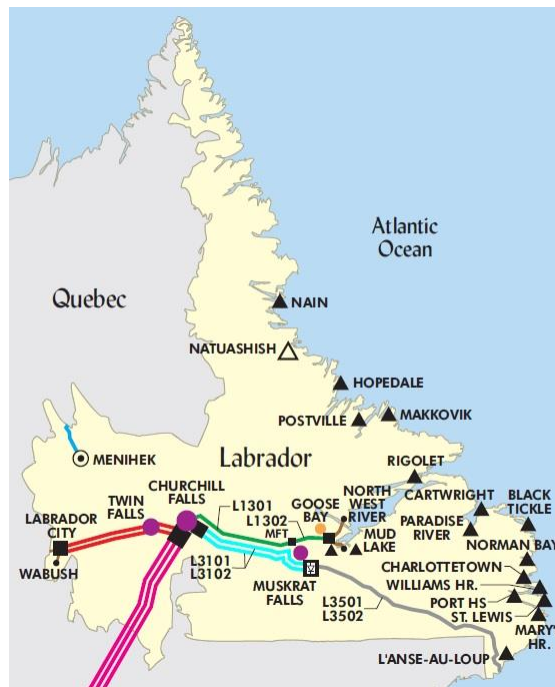

**Figure 1: Labrador Electrical System**

<sup>1</sup> According to Statistics Canada, the population of Wabush was 1,906 people in 2016.

<sup>2</sup> According to Statistics Canada, the population of Labrador City was 8,622 people in 2016.

1 The Wabush Distribution System supplies electrical power to the customers in the Town of  
2 Wabush. The system consists of a 46 kV transmission line, Line 36 (“L36”), a distribution  
3 substation (Wabush Substation), and six 12.5 kV distribution feeders - Line 3 (“L3”), Line 7  
4 (“L7”), Line 9 (“L9”), Line 11 (“L11”), Line 12 (“L12”), and Line 13 (“L13”).

5  
6 The Wabush Terminal Station (“WTS”), not to be confused with the Wabush Substation, is  
7 supplied by two, 230 kV transmission lines from Churchill Falls. The WTS steps down the voltage  
8 from 230 kV to 46 kV, which is then distributed to Labrador City, Iron Ore Company of Canada  
9 (“IOC”), and the Wabush Substation. The Wabush Substation then steps the voltage down to  
10 12.5 kV, which is then distributed to the Town of Wabush. Figure 2 is a block diagram showing  
11 the configuration of the Labrador West Interconnected System.

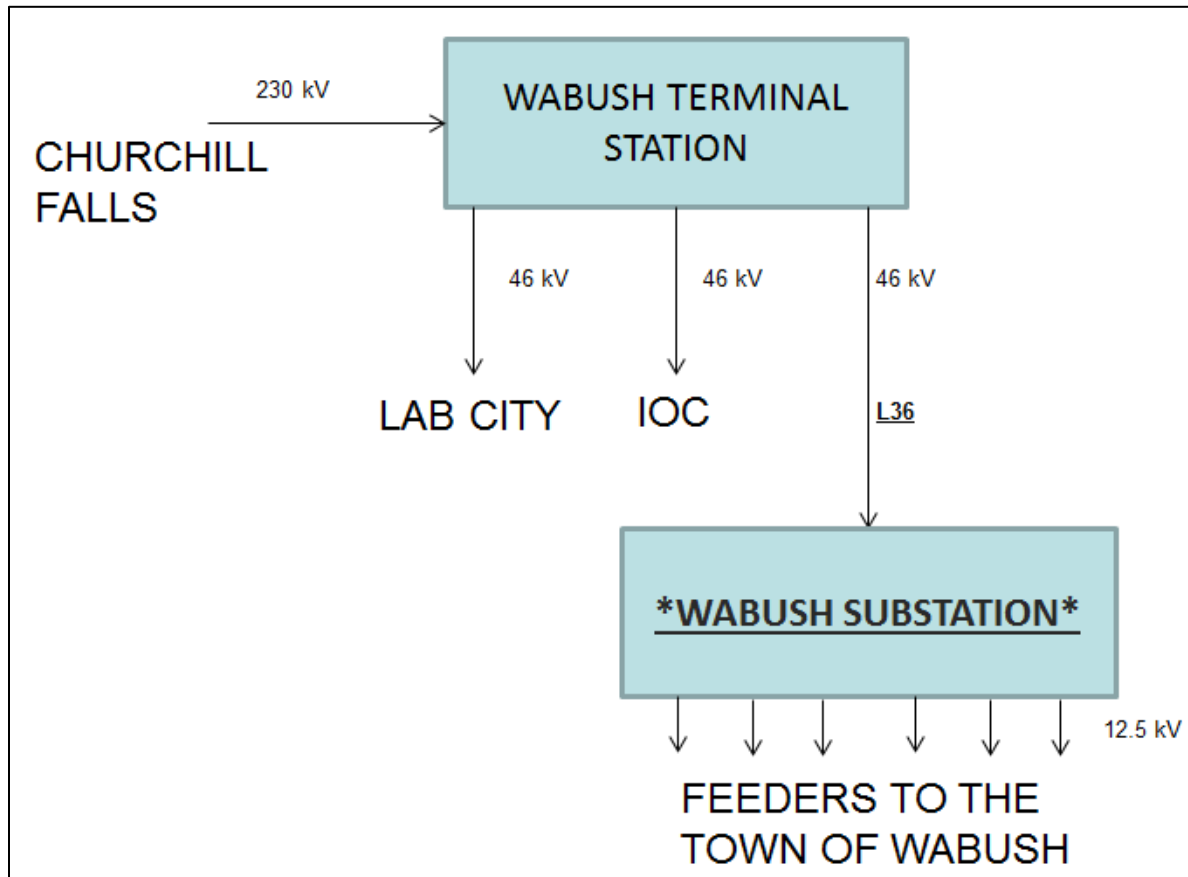

Figure 2: Labrador West Interconnected System

1   **2.1.1 Wabush Transmission Line L36**

2   The primary supply to the Wabush distribution system is Transmission Line L36, a single source  
3   46 kV line that supplies power to Hydro’s Wabush Substation from the WTS (Bus 15). The line is  
4   4.1 km long, and utilizes three-wire (delta) construction supporting 4/0 AASC phase conductors.  
5   The line was rerouted and completely rebuilt in 2009. The line is the sole supply for the Wabush  
6   Substation, and voltage regulation for the entire system is currently provided through this line  
7   by the synchronous condensers located at the WTS.

8  
9   **2.1.2 Wabush Substation**

10   The Wabush Substation has a total of four step-down power transformers that reduce the  
11   transmission line voltage from 46 kV to 12.5 kV, as listed in Table 1.

**Table 1: Wabush Substation – Power Transformers**

Transformer	Status	Voltage Rating (kV)	Power Rating (MVA) (25°C Ambient) <sup>3</sup>
T3	In Service	46/25-12.5	5/6.6/8.3
T4	Spare	46/25-12.5	5/6.6/8.3
T5	Spare	46/12.5	3/4
T6	In Service	46/12.5-4.16	10/13.3/16.67

12   Transformer T6 currently handles the majority<sup>4</sup> of the load, as it is the largest transformer and  
13   has taps that can be easily adjusted to help regulate the voltage. Transformers T4 and T5 are  
14   spares and are currently not in service, but can be connected within approximately eight hours  
15   in the event of a failure to Transformer T3 or T6. Neither of the spare transformers requires  
16   relocation to be put in service. It is noted that Transformer T4 cannot be paralleled with T3, T5,  
17   or T6, due to its present winding configuration. There is currently a capital project in the 2019

---

<sup>3</sup> For transmission planning purposes the summer, spring/fall, and winter rating limits of all power transformers and autotransformers will be equal to the nameplate rating at 25 °C ambient as provided by the manufacturer, as per Section 6.1 of *NLSO Standard – Transmission Facilities Rating Guide TP-S-001*.

<sup>4</sup> Approximately 60 percent of the town load.

1 Capital Budget Application to address this and allow Transformer T4 to be permanently  
2 connected and paralleled with T6. Work carried out under this capital project will be used with  
3 Alternatives 2, 3, and 4 of this study, and therefore funding (estimated to be \$186,700) has not  
4 been included in the cost estimates for this study. A single-line diagram of the Wabush  
5 Substation is provided in Appendix A.

6  
7 It is noted that in 2017, equipment operating at 46 kV became the responsibility of the  
8 Newfoundland and Labrador System Operator (“NLSO”) and was therefore reclassified from  
9 distribution to transmission. The Wabush Substation 46 kV transformer power ratings have  
10 subsequently been recalculated as per Section 6.1 of *NLSO Standard – Transmission Facilities*  
11 *Rating Guide TP-S-001*.

12

13 The substation has a total installed capacity (at 25°C ambient) of 37.3 MVA.

14

15 The firm transformation capacity<sup>5</sup> of the substation is 20.6 MVA.

16

### 17 **3 Current Status**

#### 18 **3.1 Ability to Meet Peak Demand**

19 Hydro’s Transmission Planning Criteria apply to all power transformers within the  
20 Newfoundland and Labrador Interconnected System.<sup>6</sup> These criteria include specification that  
21 transformers shall not be overloaded under normal operation, or in the event of the failure of  
22 another power transformer or system element.

23

24 According to the load forecasts prepared by Hydro in July of 2018, electrical demand in Wabush  
25 is due to exceed the firm transformation capacity. The expected P50 peak demand in Wabush

---

<sup>5</sup> The firm transformation capacity is the total station capacity less the transformer with the largest rating.

<sup>6</sup> Traditionally, criteria have applied to all power transformers operating at 66 kV and above. As part of the reassignment of responsibilities associated with the establishment of the NLSO, criteria now apply to all power transformers operating at 46 kV and above.

1 for the winter of 2018-2019 is 22.1 MW (or 22.6 MVA),<sup>7</sup> which exceeds the substation’s firm  
2 transformation capacity (20.6 MVA) by approximately 10 percent. An incremental 1.2 MW is  
3 assumed for a P90 forecast, equating to a peak of 22.3 MW (23.8 MVA), which exceeds the  
4 substation’s firm transformation capacity by approximately 15 percent.

5  
6 This is supported by Industrial Billing data, where the actual peak demand in Wabush for the  
7 winter of 2017-2018 was 21.2 MW (equivalent to 21.6 MVA). The substation’s firm capacity has  
8 therefore already been exceeded by approximately 5 percent.

### 10 **3.2 Reliability Limitations**

11 The Wabush Substation does not currently utilize a modern protection scheme that  
12 incorporates motor operated disconnect switches or low side circuit breakers on the power  
13 transformers. Therefore, the substation configuration does not permit the isolation of an  
14 electrical fault within the station. In addition to this, a lack of condition monitoring also causes  
15 delays in the trouble shooting process when faults occur.

16  
17 The lack of a bus tie breaker at the Wabush Substation also limits Hydro’s ability to minimize  
18 power interruptions during planned substation work.

### 20 **3.3 Load Forecast**

21 The load flow cases for this study were developed in accordance with the Long-Term Load  
22 Forecast - Spring 2018, as provided in Table 2.

---

<sup>7</sup> The power factor during peak conditions is assumed to be 0.98.

**Table 2: Long-Term Labrador Interconnected Base Case Load Forecast  
Town of Wabush Load Wabush Substation**

Year	Peak (kW) <sup>8</sup> P50	Peak (kW) <sup>8</sup> P90
2018-2019	22,069	23,269
2019-2020	22,085	23,285
2020-2021	22,149	23,349
2021-2022	22,264	23,464
2022-2023	22,377	23,577
2023-2024	22,491	23,691
2024-2025	22,578	23,778
2025-2026	22,669	23,869
2026-2027	22,760	23,960
2027-2028	22,851	24,051
2028-2029	22,937	24,137
2029-2030	23,019	24,219
2030-2031	23,100	24,300
2031-2032	23,181	24,381
2032-2033	23,263	24,463
2033-2034	23,344	24,544
2034-2035	23,426	24,626
2035-2036	23,508	24,708
2036-2037	23,590	24,790
2037-2038	23,672	24,872
2038-2039	23,754	24,954
2039-2040	23,836	25,036
2040-2041	23,918	25,118
2041-2042	24,000	25,200
2042-2043	24,082	25,282
2043-2044	24,164	25,364

**1 4 Wabush Substation Upgrade Alternatives**

2 Analysis has been completed on the 46 kV network based on the following load forecast

3 sensitivities:

4 1) Base case forecast excluding data centers:

---

<sup>8</sup> Peak and energy equate to distribution system requirements at terminal station delivery points.

Source: Market Analysis Section, Rural Planning Department  
July 16, 2018



- 1           a. Wabush Substation 2043 - 2044 Peak Coincident Load = 25.4 MW  
2           2) Base case forecast including data centers  
3           a. Wabush Substation 2043 - 2044 Peak Coincident Load = 25.9 MW  
4

#### 5 **4.1 Study Assumptions**

- 6       • Both Churchill Falls units A10 and A11 are in service at full load.
- 7       • The Churchill Falls 230 kV bus B23 voltage is held at 238 kV (1.0348 pu).<sup>9</sup>
- 8       • The voltages at WTS 46 kV buses B13 and B15 are held at 46.6 kV (1.013 pu).<sup>10</sup>
- 9       • Synchronous condenser bus voltages must be maintained between 13.1 kV (0.95 pu)  
10       and 14.5 kV (1.05 pu) for normal operation, and between 12.4 kV (0.90 pu) and 15.2 kV  
11       (1.10 pu) for line out contingencies.
- 12       • The maximum operating temperature for the existing 46 kV transmission lines is  
13       assumed to be 50°C.
- 14       • Load power factors are as follows:
  - 15           ○ Labrador City and Wabush Town Sites: 0.975 for peak cases; and
  - 16           ○ data centres: 0.975.
- 17       • As a sensitivity, an incremental 0.5 MW of 12.5 kV data centre load is assumed to be  
18       supplied from the Wabush Substation.

#### 19

#### 20 **4.2 Description of Alternatives**

21 The following alternatives were considered for this investigation and are described in detail in  
22 Appendix B of this document:

- 23       • Wabush Substation Transformer Configuration Upgrade – Two Transformers;
- 24       • Wabush Substation Transformer Configuration Upgrade – Three Transformers;
- 25       • Wabush Terminal Station – Addition of 12.5 kV Bus; and
- 26       • Flora Lake Terminal Station – Addition of 12.5 kV Bus.

---

<sup>9</sup> This represents the low voltage alarm limit for Bus B23.

<sup>10</sup> As per *WTS Operating Procedure, Book 4, Section 10.0*.

1 **5 Economic Analysis of Alternatives**

2 The economic analysis involved a comparison of the cumulative present worth (“CPW”) of each  
3 option for a study period of 25 years. The discount rate used in the study is 5.9 percent which  
4 reflects Hydro’s current long-term weighted average cost of capital. The economic analysis for  
5 this study was based on the forecast described in Section 3. The CPW analysis for each option  
6 was performed using the following information:

- 7 • estimated capital costs (refer to Section 5.2);
- 8 • estimated operating costs;
- 9 • forecasted energy costs (\$ per kWh);
- 10 • operating load forecast (kW);
- 11 • transformer no-load and load losses (kW);
- 12 • estimated asset replacement costs and years; and
- 13 • transformer remaining book values.

14  
15 Capital and operating cost estimates were generated. The projected replacement year for each  
16 major asset in the existing Wabush Substation is summarized in Table 3.

**Table 3: Major Asset Replacement Schedule**

<b>Asset</b>	<b>Replacement Year (Projected)</b>
Transformer T3	2024
Transformer T4	2050
Transformer T5	2043
Transformer T6	2057

17 The total annual costs associated with transformer power losses were calculated using  
18 forecasted energy costs (\$ per kWh), no-load/load losses (kW) for each transformer and the  
19 forecast described in Section 3.3.

1 **5.1 Economic Analysis Assumptions and Exclusions**

- 2 • Costs for supervisory control and data acquisition (“SCADA”) monitoring upgrades have  
3 been excluded. It is assumed that these costs would not be materially different for the  
4 four alternatives under consideration.
- 5 • It is assumed that construction costs could vary.
- 6

7 **5.2 Budget Estimates**

8 Table 4 provides a breakdown of the high-level (class 5) capital cost estimate associated with  
9 each station configuration evaluated. It is noted that these numbers are preliminary, and  
10 further detailed estimates are required to confirm the most cost efficient alternative.

11

12 Alternative 1 has the highest capital cost, mainly due to the high cost of the two new 33.25  
13 MVA transformers. Alternatives 3 and 4 have higher costs as well, mainly due to the reliability  
14 upgrades to Wabush Substation, on top of the costs associated with building 12.5 kV bus  
15 additions at the terminal stations.

**Table 4: Projected Budget Estimate (\$ million)**

<b>Alternatives</b>	<b>Cost</b>
Alt 1 Wabush Substation Upgrade – 2 Transformer Configuration	13.4
Alt 2 Wabush Substation Upgrade – 3 Transformer Configuration	8.4
Alt 3 Wabush Terminal Station Addition of 12.5 kV Bus	12.3
Alt 4 Flora Lake Terminal Station Addition of 12.5 kV Bus	13.0

16 **5.3 Economic Analysis Summary**

17 The results of the economic analysis are summarized in Table 5.

**Table 5: Economic Analysis Summary  
Alternative Comparison  
Cumulative Net Present Value to the year 2043 (\$ million)**

Alternative	CPW	Difference
Alt 2 Wabush Substation Upgrade – 3 Transformer Configuration	6.1	0
Alt 3 Wabush Terminal Station Addition of 12.5 kV Bus	9.9	3.8
Alt 4 Flora Lake Terminal Station Addition of 12.5 kV Bus	10.4	4.3
Alt 1 Wabush Substation Upgrade – 2 Transformer Configuration	10.4	4.3

- 1 Alternative 2 is the least cost option over Alternative 3 by a CPW difference of \$3.8 million. This
- 2 difference in is attributed to additional costs in Alternative 3 associated with the additional 12.5
- 3 kV bus in WTS. Figure 3 is a graphical representation of the cumulative net present value of
- 4 each alternative from the year 2018 to 2043.

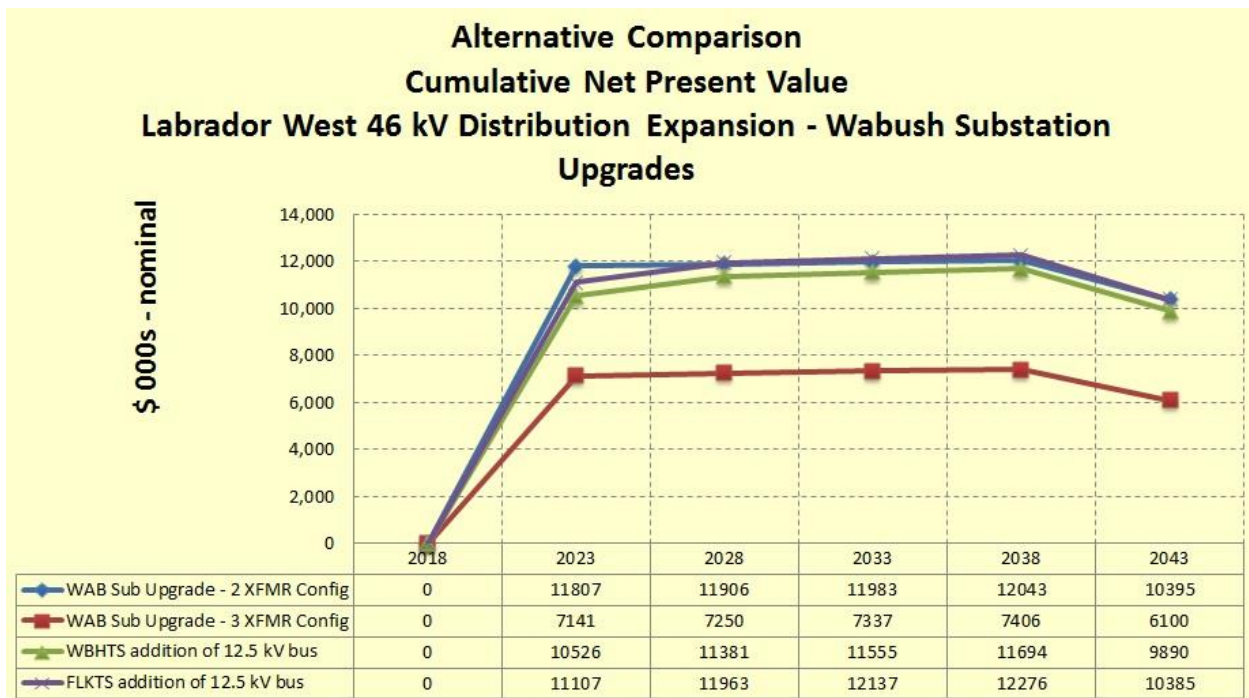

**Figure 3: Alternative Comparison – Cumulative Net Present Value**

1 **6 Recommendations**

2 On the basis of this analysis, it is recommended that an additional 15/20/25 MVA transformer  
3 and associated terminal station upgrades be installed at Wabush Substation, as described in  
4 Wabush Substation Transformer Configuration Upgrade – Three Transformers (Appendix B of  
5 this document). This new transformer would be capable of supporting baseline load forecasts  
6 for the Town of Wabush until 2038-2039.

## **Appendix A**

### Single-Line Diagram

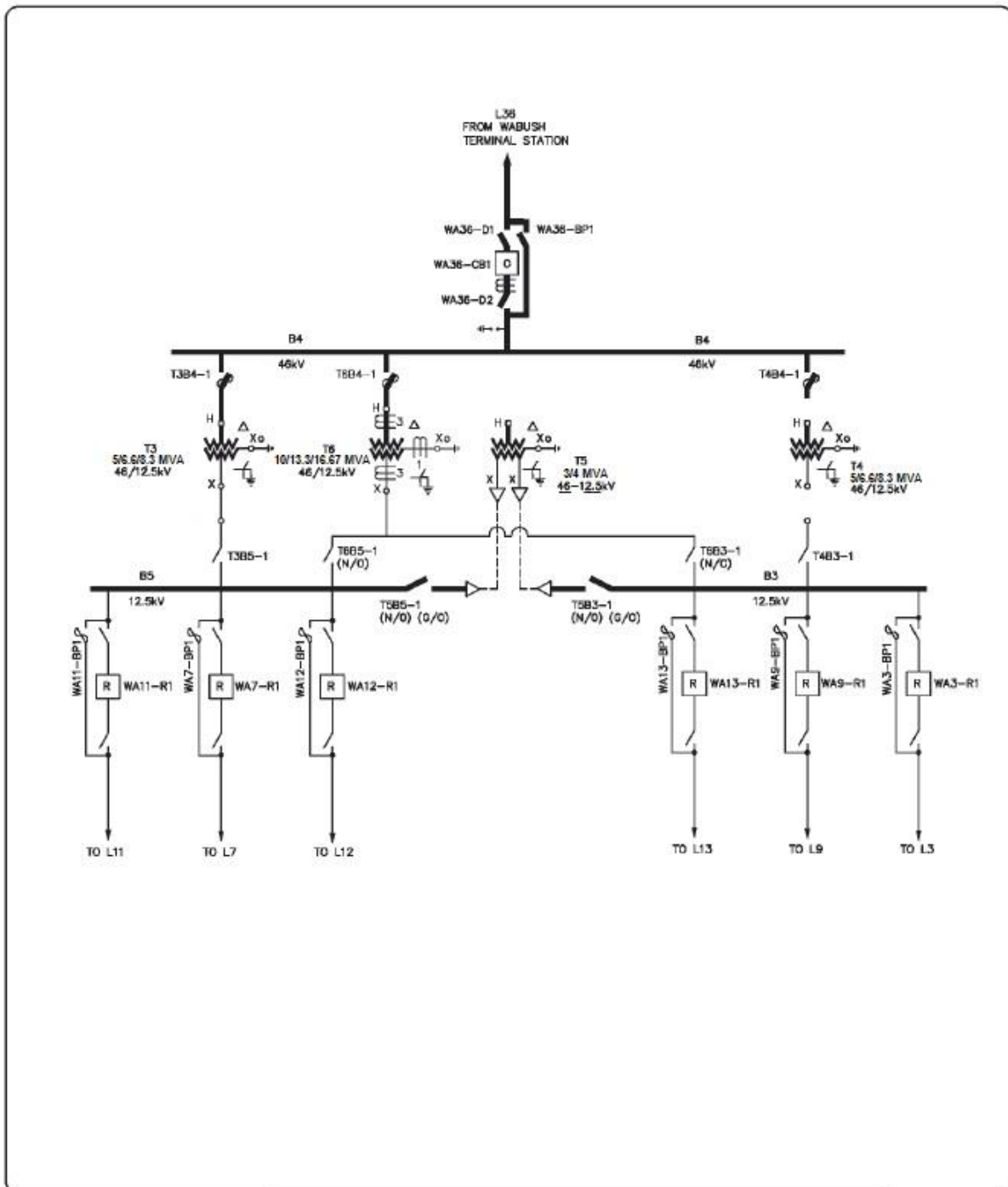

DRAWN BY D.R.	NEWFOUNDLAND AND LABRADOR HYDRO	DWG NO WAB-1
APPROVED BY D. O'DELL	SYSTEM OPERATING DIAGRAM WABUSH SUBSTATION (TEMPORARY CONNECTION FOR T6)	REV NO 1
DATE 2014/12/16		

Figure A1: Existing Wabush Substation Single-Line Diagram

## **Appendix B**

### Description of Alternatives



1 The following sections summarize the preliminary scope for alternatives to provide incremental  
2 transformer capacity for the Wabush Substation.

3

#### 4 **Wabush Substation Transformer Configuration Upgrade – Two Transformers**

5 In this scenario, the four existing 46/12.5 kV transformers would be replaced with two new  
6 33.25 MVA units in parallel. The station would then have installed redundancy, as each power  
7 transformer would be able to support the entire Town of Wabush load. The two new power  
8 transformers would be equipped with on-load tap changers (“OLTC”), which would regulate the  
9 voltage on the 12.5 kV buses and eliminate any low voltage conditions on the distribution  
10 system for the foreseeable future. A 12.5 kV breaker would be installed on the low side of each  
11 power transformer, while motorized disconnects would be installed on the high side. This  
12 arrangement would allow for the quick isolation of a fault with minimal disruption to the  
13 unaffected areas of the system. The 46 kV oil filled circuit breaker would be replaced, as it is  
14 reaching the end of its useful life. To provide additional reliability, a bus tie circuit breaker  
15 would be added between 12.5 kV buses B5 and B3. All the existing transformers would no  
16 longer be utilized in the Wabush Substation and would be stored as spares or utilized  
17 elsewhere in the system. A new control building would be purchased and installed on the south  
18 side of the station. This building would house all the protection, control and communication  
19 equipment.

20

21 The following is a summary of the work involved with this alternative (refer to Figure B1 and  
22 Figure B2 for high level details of work required):

- 23 • removal of 46/12.5 kV transformers T3, T4, T5, and T6. Transformers to be stored for  
24 possible future use;
- 25 • removal of all manual disconnect switches associated with transformers T3 to T6;
- 26 • removal of 46 kV circuit breaker WA36-CB1, associated disconnects, and bypass switch;
- 27 • purchase and installation of two, 46/25-12.5 kV, 20/26.6/33.25 MVA transformers,  
28 complete with OLTC;

- 1       • purchase and installation of two, 2000 A, 15 kV vacuum circuit breakers, complete with
- 2       two sets of current transformers (“CTs”), for secondary of each power transformer;
- 3       • purchase and installation of one, 1000 A, 15 kV vacuum circuit breaker, complete with
- 4       two sets of CTs, two disconnect switches, and a bypass fused disconnect switch;
- 5       • purchase and installation of two, 46 kV motor operated disconnect switches to be
- 6       located between bus B4 and the two new transformers;
- 7       • purchase and installation of two, 12.5 kV disconnect switches to be located between bus
- 8       B5 and Transformer T1, and between bus B3 and Transformer T2;
- 9       • purchase and installation of a new 46 kV, 600 A SF6 breaker, complete with two sets of
- 10       CTs, two motor operated disconnect switches, and a bypass fused disconnect switch, to
- 11       replace WA36-CB1; and
- 12       • replace the control building.

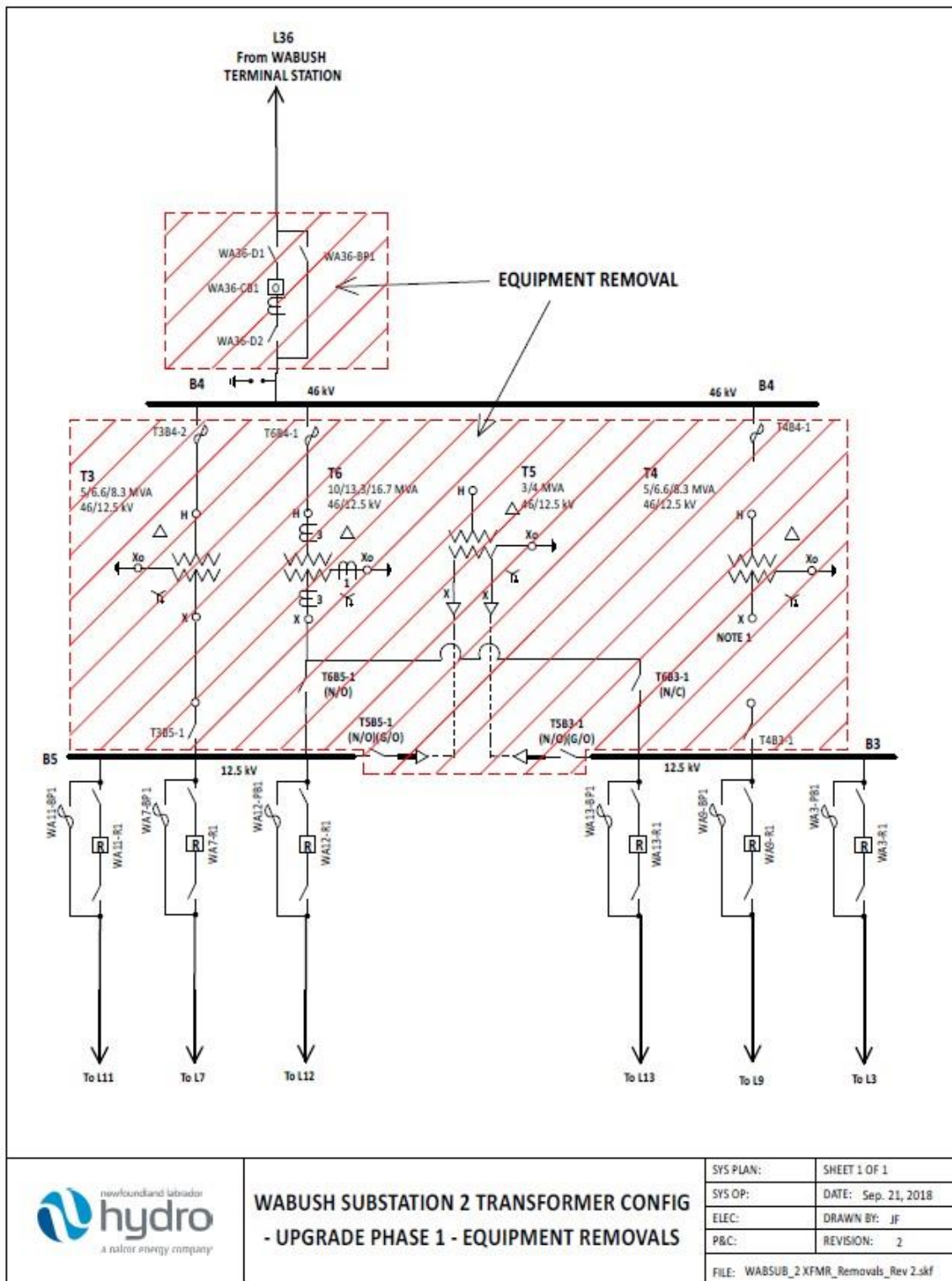

Figure B1: Wabush Substation 2 Transformer Configuration – Upgrade Phase 1 – Equipment Removals

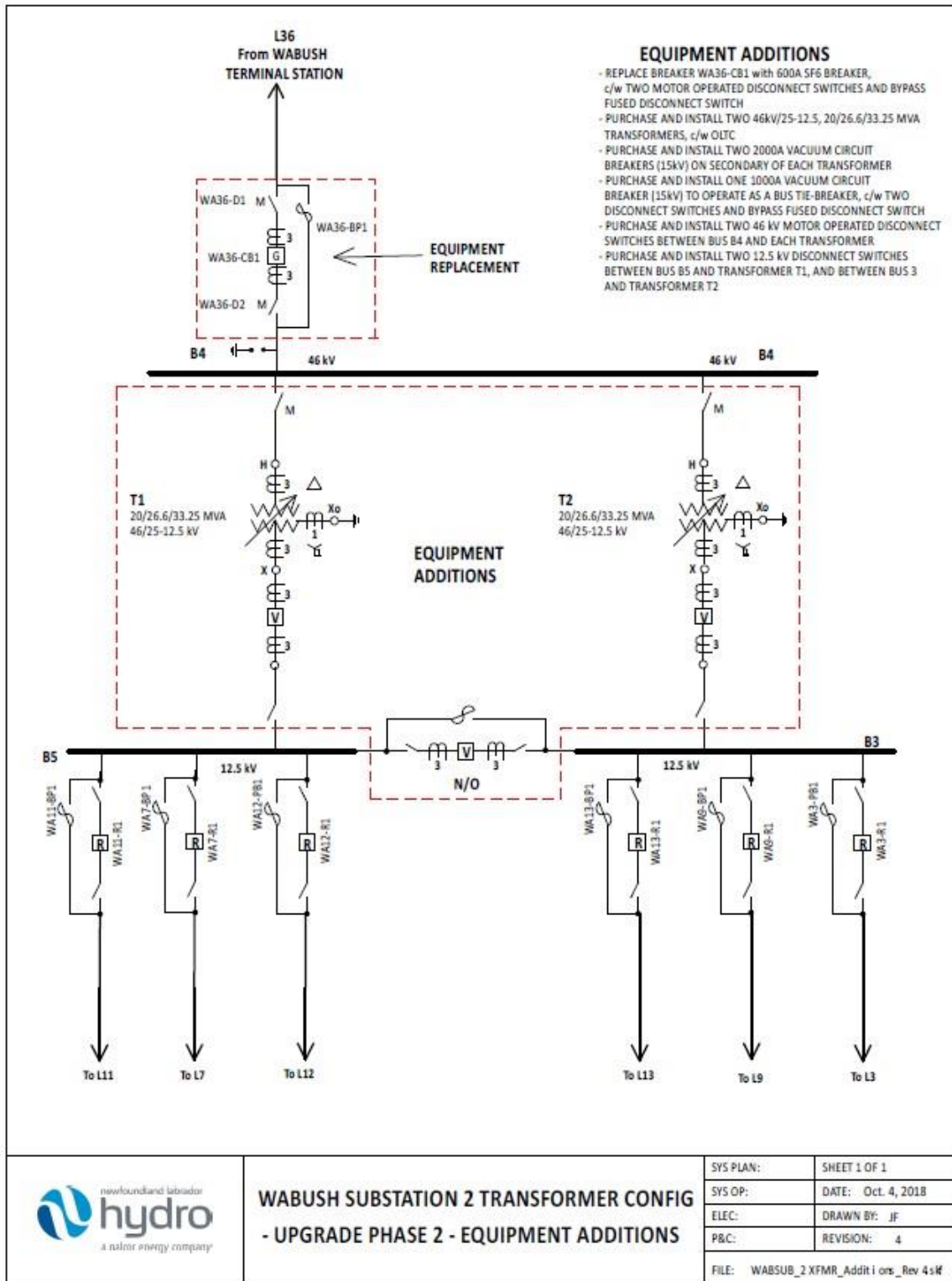

Figure B2: Wabush Substation 2 Transformer Configuration – Upgrade Phase 2 – Equipment Additions

## 1 **Wabush Substation Transformer Configuration Upgrade – Three Transformers**

2 In this scenario, two of the existing 46/12.5 kV transformers, T4 and T6, would be utilized, while  
3 the other two, T3 and T5, would be removed and stored as spares. An additional 25 MVA unit  
4 complete with OLTC for voltage regulation, T7, would be installed. This new transformer would  
5 be capable of supporting the entire Town of Wabush load until 2038-2039, at which time  
6 Transformer T4 would be upgraded with a 16.7 MVA unit complete with OLTC. Transformer T4  
7 would be used as a spare, in the event of a failure to Transformer T7. It is assumed that the  
8 capital project in the 2019 Capital Budget Application to allow T4 to be permanently connected  
9 will be approved. In this configuration, Transformer T7 must not be paralleled with T4 or T6 as  
10 it would increase the fault levels beyond the interrupting ratings of the reclosers. A 12.5 kV  
11 breaker would be installed on the low side of each power transformer, while motorized  
12 disconnects would be installed on the high side. This arrangement would allow for the quick  
13 isolation of a fault with minimal disruption to the unaffected areas of the system. Voltage  
14 regulators would be installed on both L11 and L13, as these are the most heavily loaded feeders  
15 and have experienced low voltages at the end of their lines. In the event that Transformer T7 is  
16 out of service, the voltage regulators would provide voltage regulation on those lines. The 46 kV  
17 oil filled circuit breaker would be replaced, as it is reaching the end of its useful life. To provide  
18 additional reliability, a bus tie circuit breaker would be added between 12.5 kV buses B5 and  
19 B3. A new control building would be purchased and installed on the south side of the station.  
20 This building would house all the protection, control and communication equipment.

21  
22 The following is a summary of the work involved with this alternative (refer to Figure B3 and  
23 Figure B4 for high level details of work required):

- 24 • removal of 46/12.5 kV transformers T3 and T5. Transformers to be stored for possible  
25 future use;
- 26 • removal of all manual disconnect switches associated with transformers T3 and T5;
- 27 • removal of 46 kV circuit breaker WA36-CB1, associated disconnects and bypass switch;

- 1 • purchase and installation of one, 46/4.16-12.5 kV, 15/20/25 MVA transformer, complete
- 2 with OLTC;
- 3 • completion of necessary refurbishments/upgrades on the existing transformers T4 and
- 4 T6;
- 5 • upgrades to both 12.5 and 46 kV bus work;
- 6 • purchase and installation of three, 2000 A, 15 kV vacuum circuit breakers, complete
- 7 with two sets of CTs, for secondary of each power transformer;
- 8 • purchase and installation of one, 1000 A, 15 kV vacuum circuit breaker, complete with
- 9 two sets of CTs, two disconnect switches, and a bypass fused disconnect switch;
- 10 • purchase and installation of three, 46 kV motor operated disconnect switches to be
- 11 located between bus B4 and the three transformers;
- 12 • purchase and installation of three, 12.5 kV disconnect switches to be located between
- 13 bus B5 and transformer T6 and between bus B3 and transformers T4 and T7;
- 14 • purchase and installation of new 46 kV, 600 A SF6 breaker, complete with two sets of
- 15 CTs, two motor operated disconnect switches, and a bypass fused disconnect switch, to
- 16 replace WA36-CB1;
- 17 • purchase and installation of two sets of 400 A, 12.5 kV voltage regulators, one to be
- 18 installed on feeder L11, and the other to be installed on feeder L13;
- 19 • purchase of one spare 400 A voltage regulator; and
- 20 • replace the control building.

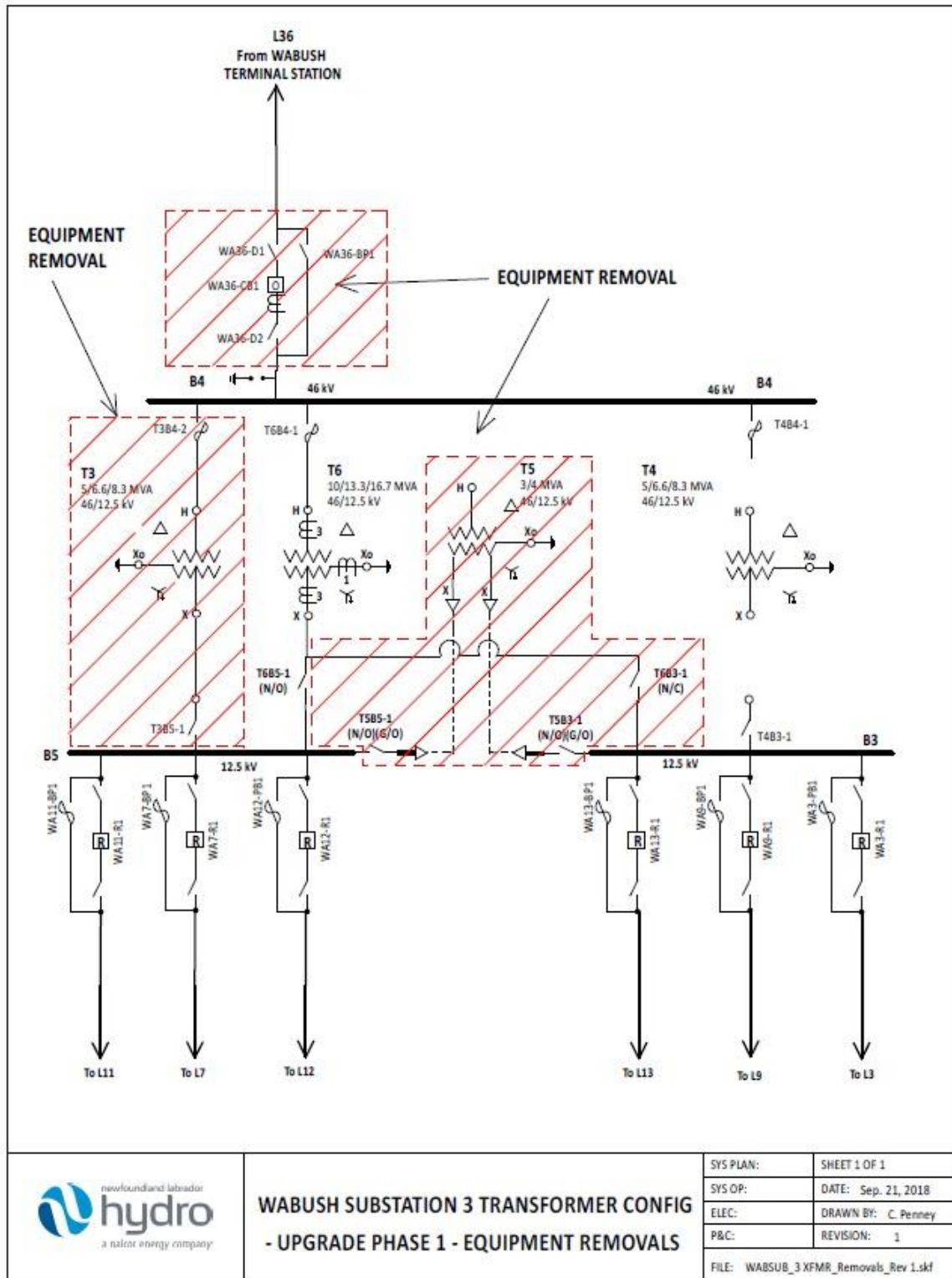

Figure B3: Wabush Substation 3 Transformer Configuration – Upgrade Phase 1 – Equipment Removals







1 **Wabush Terminal Station – Addition of 12.5 kV Bus**

2 In this scenario, the WTS would be expanded by the construction of a 12.5 kV bus. A new 12.5  
3 kV distribution line would be built to supply the load at Wabush Industrial Park (thus offloading  
4 Wabush Substation feeders L11 and L13 would be tied together and connected to Wabush  
5 Terminal Station via the new 12.5 kV line, as illustrated in Figure B5.

6  
7 Refer to Figure B6 for high level details of the work required at the WTS.

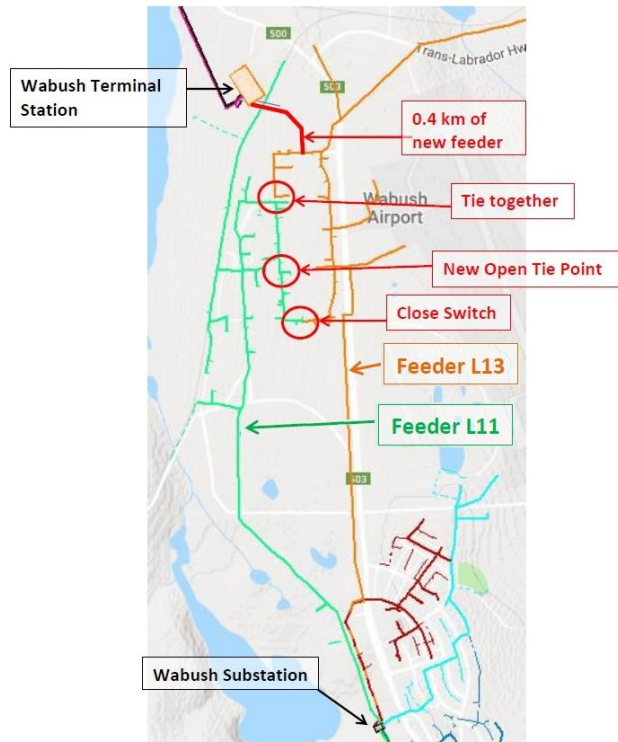

**Figure B5: Overview of Proposed Changes to Wabush Industrial Park Distribution Feeders**

8 To improve reliability at Wabush Substation, several upgrades would be implemented. A 12.5  
9 kV breaker would be installed on the low side of each power transformer, while motorized  
10 disconnects would be installed on the high side. This arrangement would allow for the quick  
11 isolation of a fault with minimal disruption to the unaffected areas of the system. It is assumed  
12 that the capital project in the 2019 Capital Budget Application to allow Transformer T4 to be

1 permanently connected will be approved. Voltage regulators would be installed on both L11  
2 and L13, as these are the most heavily loaded feeders and have experienced low voltages at the  
3 end of their lines. The 46 kV oil filled circuit breaker would be replaced, as it is reaching the end  
4 of its useful life. To provide additional reliability, a bus tie circuit breaker would be added  
5 between 12.5 kV buses B5 and B3. A new control building would be purchased and installed on  
6 the south side of the station. This building would house all the protection, control and  
7 communication equipment. Refer to Figure B7 and Figure B8 for high level details of the work  
8 required at Wabush Substation.

9

10 The following is a summary of the work involved with this alternative at the WTS:

- 11 • installation of new 12.5 kV terminal station extension at the WTS at bus B15.  
12 Termination of new distribution line LX<sup>11</sup> is required, with consideration of space  
13 requirements for the provision of a future second feeder;
- 14 • purchase and installation of two, 46/12.5 kV, 10/13.3/16.7 MVA transformers complete  
15 with OLTC at the WTS;
- 16 • purchase and installation of two, 1200 A, 15 kV vacuum circuit breakers, complete with  
17 two sets of CTs, for secondary of each power transformer;
- 18 • purchase and installation of four surge arrestors, to be installed on each side of the two  
19 transformers;
- 20 • purchase and installation of two, 46 kV motor operated disconnect switches to be  
21 located between bus B15 and the two new transformers;
- 22 • purchase and installation of two, 12.5 kV disconnect switches to be located between the  
23 12.5 kV bus and the vacuum circuit breakers on the secondary side of the transformers;
- 24 • purchase and installation of one, 1200 A, 15 kV vacuum circuit breaker, complete with  
25 two sets of CTs, two disconnect switches, and a bypass fused disconnect switch;

---

<sup>11</sup> Distribution line to be named at a later date.

- 1 • purchase and installation of one, 12.5 kV recloser, type Cooper Nova 27 with 16 kA
- 2 interrupting rating, complete with bypass fused disconnect switch;
- 3 • construction of approximately 0.4 km of 12.5 kV distribution feeder along the railway
- 4 track from the WTS to Pole 125 on Wabush Industrial Park feeder L13 with 477 ASC
- 5 primary, a 4/0 AASC neutral and a designed conductor temperature of 75°C; and
- 6 • purchase and installation of a gang operated disconnect switch to serve as a tie switch
- 7 for the new open tie point.

8

9 The following is a summary of the work involved with this alternative at Wabush Substation:

- 10 • removal of all manual disconnect switches associated with transformers T3, T4, T5, and
- 11 T6;
- 12 • removal of 46 kV circuit breaker WA36-CB1, associated disconnects and bypass switch;
- 13 • purchase and installation of four, 2000 A, 15 kV vacuum circuit breakers, complete with
- 14 two sets of CTs, for secondary of each power transformer;
- 15 • purchase and installation of one, 1000 A, 15 kV vacuum circuit breaker, complete with
- 16 two sets of CTs, two disconnect switches, and a bypass fused disconnect switch;
- 17 • purchase and installation of four, 46 kV motor operated disconnect switches to be
- 18 located between bus B4 and the four transformers;
- 19 • purchase and installation of four, 12.5 kV disconnect switches to be located between
- 20 bus B5 and transformers T3 and T5 and between bus B3 and transformers T4 and T6;
- 21 • purchase and installation of a new 46 kV, 600 A SF6 breaker, complete with two sets of
- 22 CTs, two motor operated disconnect switches, and a bypass fused disconnect switch, to
- 23 replace WA36-CB1;
- 24 • purchase and installation of two sets of 400 A, 12.5 kV voltage regulators, one to be
- 25 installed on feeder L11, and the other to be installed on feeder L13;
- 26 • purchase of one spare 400 A voltage regulator; and
- 27 • replace the control building.

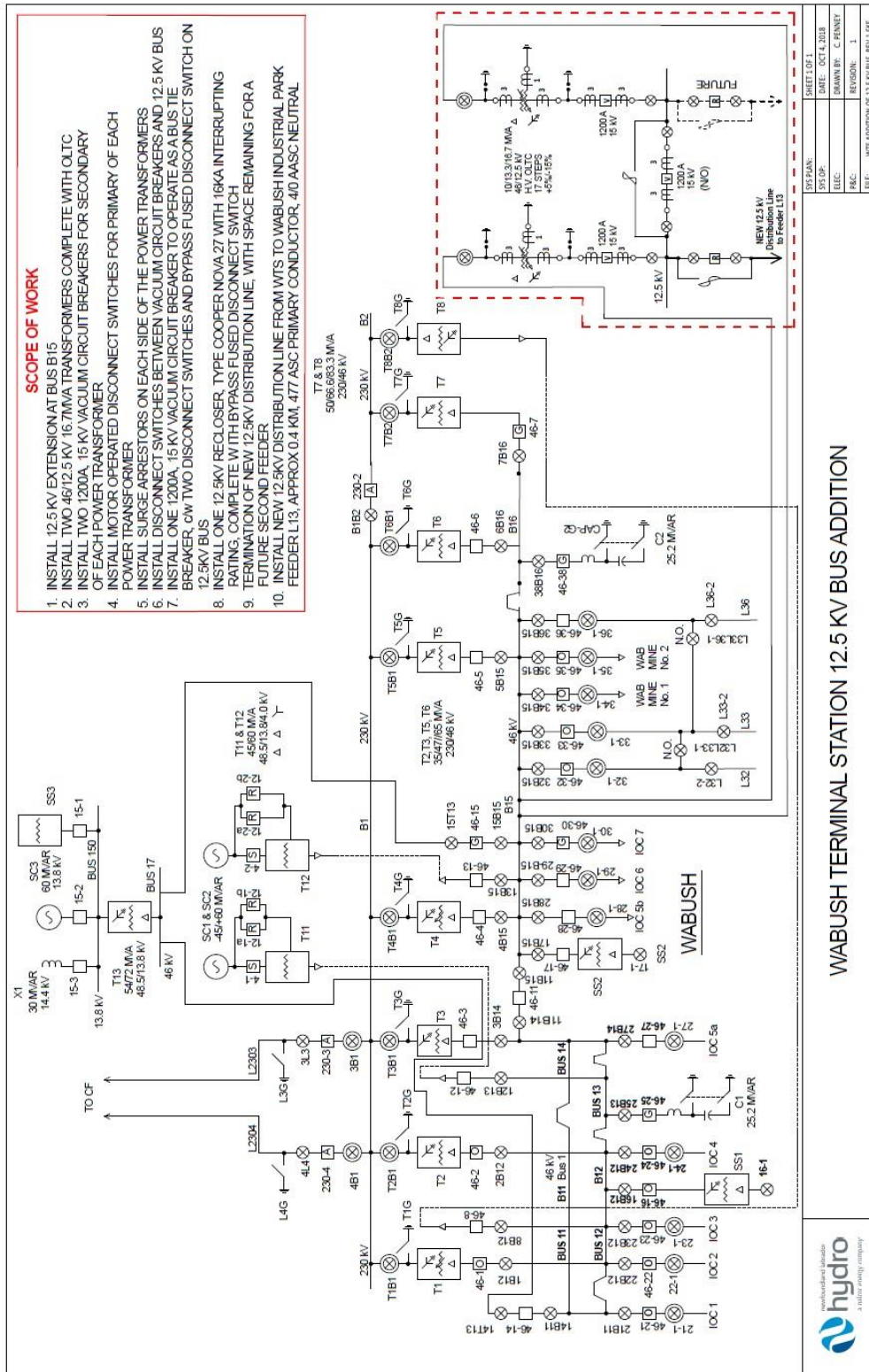

WABUSH TERMINAL STATION 12.5 KV BUS ADDITION



Figure B6: Wabush Terminal Station – Addition of 12.5 kV Bus

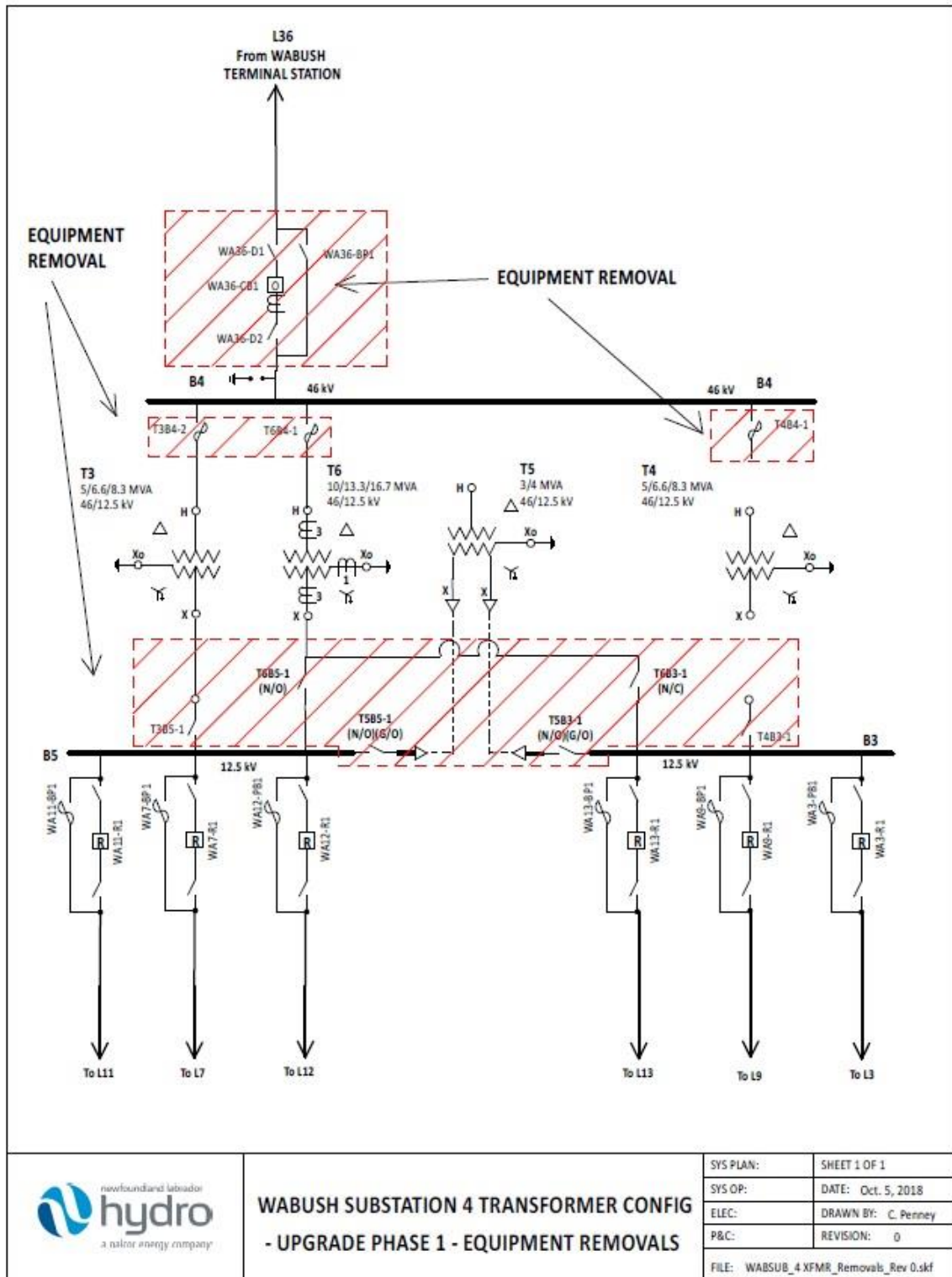

Figure B7: Wabush Substation 4 Transformer Configuration – Upgrade Phase 1 – Equipment Removals



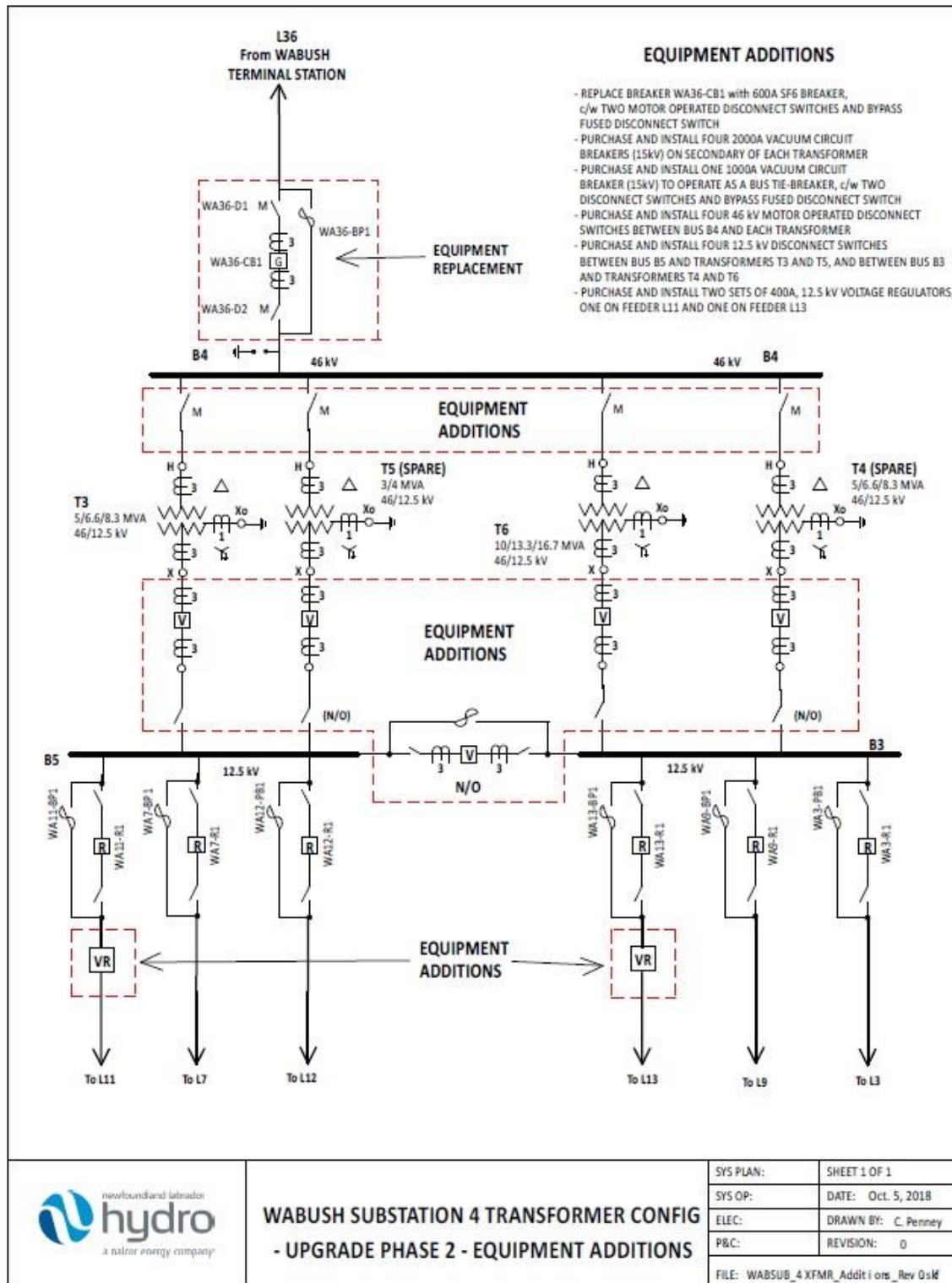

Figure B8: Wabush Substation 4 Transformer Configuration – Upgrade Phase 2 – Equipment Additions

1 **Flora Lake Terminal Station – Addition of 12.5 kV Bus**

2 An investigation was performed to assess opportunities for 12.5 kV supply from Flora Lake  
3 (“FLK”) Terminal Station if this station were to be established to meet high voltage capacity  
4 requirements for western Labrador.<sup>12</sup> Two new 12.5 kV distribution lines would be built to  
5 supply the load at Wabush Industrial Park (thus offloading Wabush Substation by approximately  
6 30%). Wabush Substation feeders L11 and L13 would each be tied to new 12.5 kV lines from  
7 FLK, as illustrated in Figure B9.

8

9 Refer to Figure B10 for high level details of the work required.

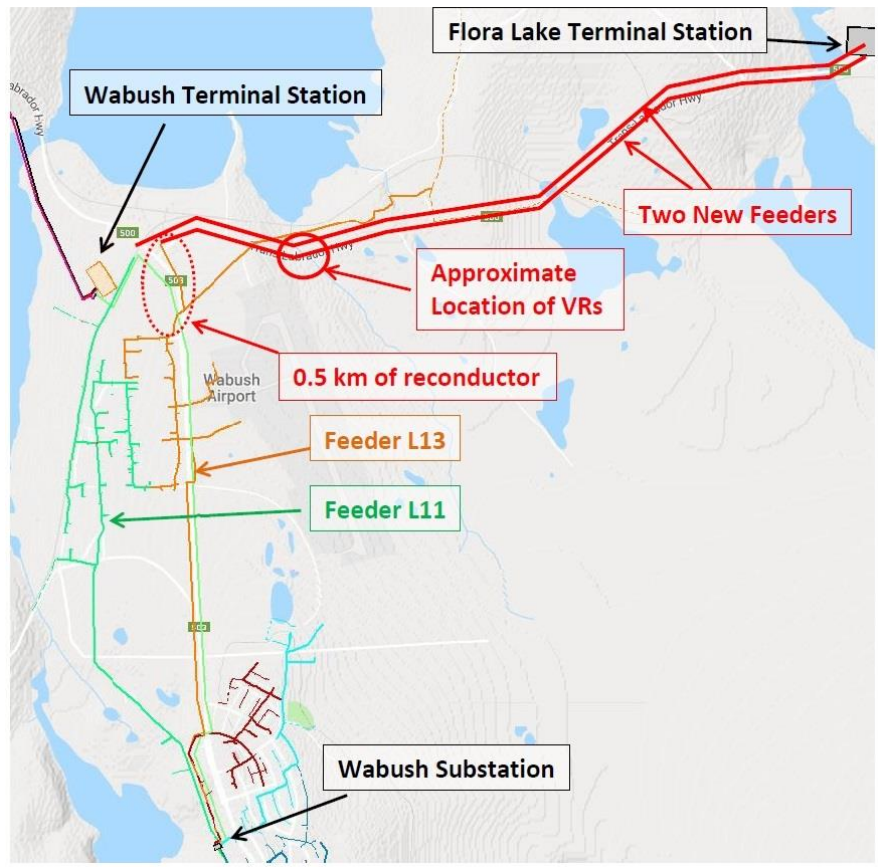

**Figure B9: Overview of Proposed 12.5 kV Feeders from Flora Lake Terminal Station**

<sup>12</sup> The high voltage transmission system in western Labrador is being studied in a separate analysis.

1 To improve reliability at Wabush Substation, several upgrades would be implemented. A 12.5  
2 kV breaker would be installed on the low side of each power transformer, while motorized  
3 disconnects would be installed on the high side. This arrangement would allow for the quick  
4 isolation of a fault with minimal disruption to the unaffected areas of the system. It is assumed  
5 that the capital project in the 2019 Capital Budget Application to allow T4 to be permanently  
6 connected will be approved. Voltage regulators would be installed on both L11 and L13, as  
7 these are the most heavily loaded feeders and have experienced low voltages at the end of  
8 their lines. The 46 kV oil filled circuit breaker would be replaced, as it is reaching the end of its  
9 useful life. To provide additional reliability, a bus tie circuit breaker would be added between  
10 12.5 kV buses B5 and B3. A new control building would be purchased and installed on the south  
11 side of the station. This building would house all the protection, control and communication  
12 equipment. Refer to Figure B7 and Figure B8 for high level details of the work required at  
13 Wabush Substation.

14  
15 The following is a summary of the work involved with this alternative at FLK Terminal Station:

- 16 • installation of 12.5 kV terminal station extension at FLK Terminal Station. Termination of  
17 two new distribution lines LX1 and LX2<sup>13</sup> to Wabush Industrial Park is required;
- 18 • purchase and installation of two, 46/12.5 kV, 10/13.3/16.7 MVA transformers complete  
19 with OLTC at FLK Terminal Station;
- 20 • purchase and installation of two, 1200 A, 15 kV vacuum circuit breakers, complete with  
21 two sets of CTs, for secondary of each power transformer;
- 22 • purchase and installation of two, 46 kV motor operated disconnect switches to be  
23 located between the 46 kV bus and two, 46/12.5 kV transformers;
- 24 • purchase and installation of four surge arrestors, to be installed on each side of the two  
25 transformers;

---

<sup>13</sup> Distribution line to be named at a later date.



- 1       • purchase and installation of one, 1200 A, 15 kV vacuum circuit breaker, complete with
- 2       two sets of CTs, two disconnect switches, and a bypass fused disconnect switch;
- 3       • purchase and installation of two, 12.5 kV disconnect switches to be located between the
- 4       12.5 kV bus and the vacuum circuit breakers on the secondary side of the transformers;
- 5       • purchase and installation of two, 12.5 kV reclosers, type Cooper Nova 27 with 16 kA
- 6       interrupting rating, complete with bypass fused disconnect switches;
- 7       • construction of approximately 5 km of 12.5 kV distribution feeder along the Trans-
- 8       Labrador Highway from FLK Terminal Station to the intersection with Route 503,
- 9       connecting with the nearest suitable pole on Wabush Industrial Park feeder L11. The
- 10      line is to be constructed using conductor 4/0 AASC primary, a 1/0 AASC neutral and a
- 11      designed conductor temperature of 75°C;
- 12      • construction of approximately 5 km of 12.5 kV distribution feeder along the Trans-
- 13      Labrador Highway from FLK Terminal Station to the intersection with Route 503,
- 14      connecting with the nearest suitable pole on Wabush Industrial Park feeder L13. The
- 15      line is to be constructed using conductor 4/0 AASC primary, a 1/0 AASC neutral and a
- 16      designed conductor temperature of 75°C;
- 17      • purchase and installation of two sets of 300 A voltage regulators on the two new 12.5 kV
- 18      distribution lines, with approximate locations as indicated on the map in Figure B5;
- 19      • purchase of one spare 300 A voltage regulator; and
- 20      • reconductor approximately 0.5 km of 12.5 kV distribution feeder L13 between the
- 21      Wabush Industrial Park and the intersection of the Trans-Labrador Highway and Route
- 22      503, as indicated on the map in Figure B5. Existing 1/0 AASC conductor to be replaced
- 23      with 4/0 AASC with a designed conductor temperature of 75°C.

24

25 The following is a summary of the work involved with this alternative at Wabush Substation:

- 26       • removal of all manual disconnect switches associated with transformers T3, T4, T5, and
- 27       T6;
- 28       • removal of 46 kV circuit breaker WA36-CB1, associated disconnects and bypass switch;

- 1       ● purchase and installation of four, 2000 A, 15 kV vacuum circuit breakers, complete with
- 2       two sets of CTs, for secondary of each power transformer;
- 3       ● purchase and installation of one, 1000 A, 15 kV vacuum circuit breaker, complete with
- 4       two sets of CTs, two disconnect switches, and a bypass fused disconnect switch;
- 5       ● purchase and installation of four, 46 kV motor operated disconnect switches to be
- 6       located between bus B4 and the four transformers;
- 7       ● purchase and installation of four, 12.5 kV disconnect switches to be located between
- 8       bus B5 and transformers T3 and T5 and between bus B3 and transformers T4 and T6;
- 9       ● purchase and installation of new 46 kV, 600 A SF6 breaker, complete with two sets of
- 10       CTs, two motor operated disconnect switches, and a bypass fused disconnect switch, to
- 11       replace WA36-CB1;
- 12       ● Purchase and installation of two sets of 400 A, 12.5 kV voltage regulators, one to be
- 13       installed on feeder L11, and the other to be installed on feeder L13;
- 14       ● purchase of one spare 400 A voltage regulator; and
- 15       ● replace the control building.

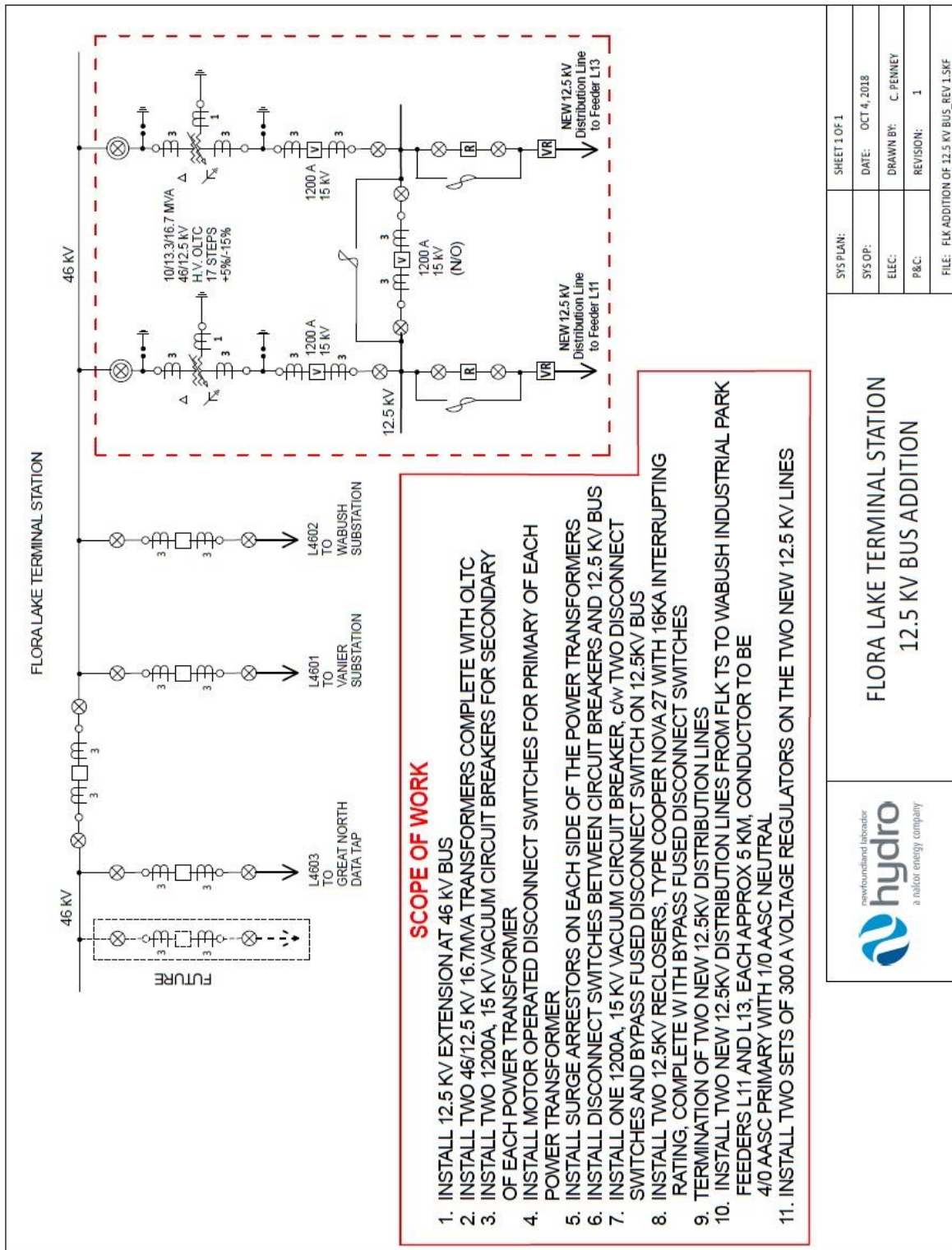

Figure B10: Flora Lake Terminal Station – Addition of 12.5 kV Bus







**Appendix D**

Labrador West 46 kV System Expansion – Existing 46 kV System and Future  
Alternatives





Labrador West 46 kV System Expansion  
Existing 46 kV System and Future Alternatives

October 2018

*A Report to the Board of Commissioners of Public Utilities*



## Table of Contents

1	Introduction .....	1
2	Overview .....	1
	2.1 Existing 46 kV System.....	1
	2.1.1 46 kV Transmission Line L32 .....	2
	2.1.2 46 kV Transmission Line L33 .....	3
	2.1.3 46 kV Transmission Line L40 .....	3
	2.1.4 46 kV Transmission Line L36 .....	3
3	Current Status .....	3
	3.1 Ability to Meet Peak Demand.....	3
4	46 kV Distribution System Alternatives .....	3
	4.1 Study Assumptions.....	4
	4.2 Description of Alternatives .....	5
5	Summary of Results .....	5

## List of Appendices

Appendix A: Description of Alternatives

1 **1 Introduction**

2 An analysis has been completed to assess the loading on 46 kV transmission lines to determine  
3 upgrade requirements to meet the range of forecasted customer loads, as summarized in  
4 Section 3.

5  
6 A load flow analysis was performed to confirm upgrade requirements for these scenarios. Cost  
7 estimates were developed and included, as appropriate, into the power system alternatives  
8 described in Appendix A of this document. Consideration was given to cases where 46 kV supply  
9 was provided solely from Wabush Terminal Station (“WTS”), as is the case for the existing  
10 system, which is described in the following section. In addition, some of the expansion  
11 alternatives involve the establishment of a new terminal station at Flora Lake (“FLK”).  
12 Consideration was therefore given to scenarios where 46 kV supply was provided from FLK as  
13 well as WTS.

14

15 **2 Overview**

16 **2.1 Existing 46 kV System**

17 The 46 kV transmission lines L32, L40, and L33, connect customers in Labrador City, and the 46  
18 kV transmission line L36 connects customers in the Town of Wabush. Refer to Figure 1 for a  
19 block diagram of this network. The descriptions of 46 kV lines are provided in Sections 2.1.1 to  
20 2.1.4.

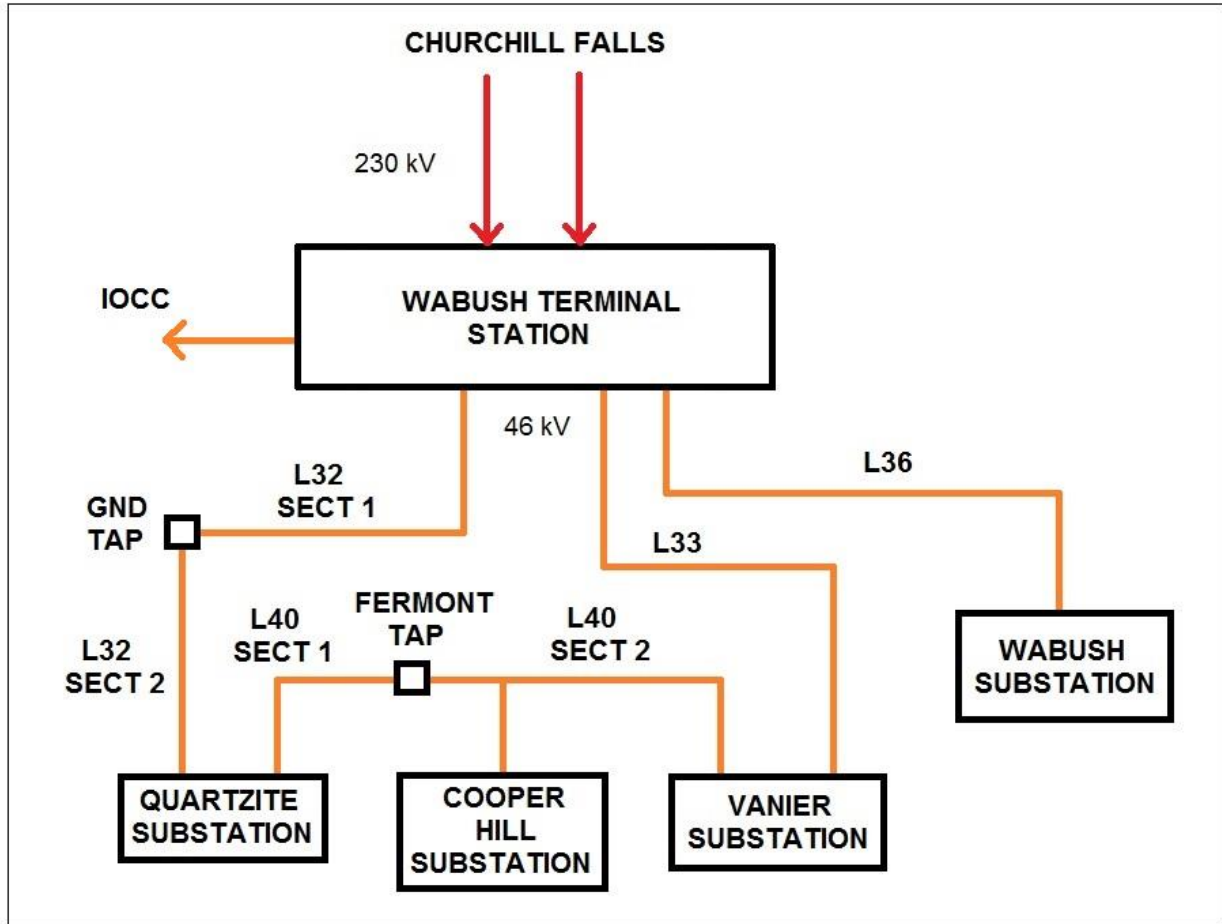

Figure 1: Labrador West 46 kV System

1 Details relating to the 46 kV transmission lines are summarized as follows:

2

3 **2.1.1 46 kV Transmission Line L32**

4 L32 connects WTS to Quartzite Substation, and is comprised of two sections:

- 5 • L32 Section 1, which has a length of 1.8 km and connects WTS to Great North Data Tap;
- 6 and
- 7 • L32 Section 2, which has a length of 3.8 km and connects Great North Data Tap to
- 8 Quartzite Substation.

9

10 Both sections are modeled as 477 ASC Cosmos conductor with a design conductor temperature  
11 of 50°C.

1 **2.1.2 46 kV Transmission Line L33**

2 L33 connects WTS to Vanier Substation, and has a length of 3.8 km and is modeled as 477 ACSR  
3 Pelican conductor with a design conductor temperature of 50°C.

4  
5 **2.1.3 46 kV Transmission Line L40**

6 L40 connects Quartzite Substation to Vanier Substation, and is comprised of two sections:

- 7 • L40 Section 1, which has a length of 2.5 km and connects Quartzite Substation to  
8 Fermont Tap, and is modeled as 266.8 ACSR Partridge conductor; and
- 9 • L40 Section 2, which has a length of 2.1 km and connects Fermont Tap to Vanier  
10 Substation, and is modeled as 477 ACSR Pelican conductor.

11  
12 **2.1.4 46 kV Transmission Line L36**

13 L36 is the primary supply to the Wabush distribution system, and connects WTS to Wabush  
14 Substation. It has a length of 4.1 km and modeled as 4/0 AASC Vancouver conductor with a  
15 design conductor temperature of 50°C.

16  
17 **3 Current Status**

18 **3.1 Ability to Meet Peak Demand**

19 The analysis was performed on the basis of reliable supply to Hydro rural customers without 46  
20 kV transmission line overloads for conditions with all lines in service or with one 46 kV  
21 transmission line out of service<sup>1</sup>.

22  
23 **4 46 kV Distribution System Alternatives**

24 Load flow analyses were performed to identify required system upgrades to ensure reliable  
25 operation of the 46 kV network for the following scenarios:

- 26 • Baseline Forecast Case;

---

<sup>1</sup> The exception is L36, which is the radial line to the Wabush Substation. This radial feed is addressed as a separate option.

- 1 • Baseline Forecast with FLK Supply Case;
- 2 • Sensitivity Forecast Case; and
- 3 • Sensitivity with FLK Supply Forecast Case.

4

#### 5 **4.1 Study Assumptions**

- 6 • Both Churchill Falls units A10 and A11 are in service at full load.
- 7 • The Churchill Falls 230 kV bus B23 voltage is held at 238 kV (1.0348 pu).<sup>2</sup>
- 8 • The voltages at WTS 46 kV buses B13 and B15 are held at 46.6 kV (1.013 pu).<sup>3</sup>
- 9 • Synchronous condenser bus voltages must be maintained between 13.1 kV (0.95 pu)
- 10 and 14.5 kV (1.05 pu) for normal operation, and between 12.4 kV (0.90 pu) and 15.2 kV
- 11 (1.10 pu) for line out contingencies.
- 12 • The maximum operating temperature for the existing 46 kV transmission lines is
- 13 assumed to be 50°C.
- 14 • Load power factors are as follows:
  - 15 ○ Labrador City and Wabush Town Sites: 0.975 for peak cases; and
  - 16 ○ data centres: 0.975.
- 17 • The P90 peak baseline load forecast includes a Hydro retail load of approximately 83.3
- 18 MW.
- 19 • Sensitivity forecasts include a total of approximately 50 MW of data centre load within
- 20 the 46 kV transmission network.

---

<sup>2</sup> This represents the low voltage alarm limit for Bus B23.

<sup>3</sup> As per *WTS Operating Procedure, Book 4, Section 10.0*.

1 **4.2 Description of Alternatives**

2 The following alternatives were considered for this investigation and are described in detail in  
3 Appendix A of this document:

- 4 • Scenario 1: Baseline Forecast;
- 5 • Scenario 2: Baseline Forecast with FLK Supply Case;
- 6 • Scenario 3: Sensitivity Forecast; and
- 7 • Scenario 4: Sensitivity Forecast with FLK Supply Case.

8

9 **5 Summary of Results**

10 Table 1 provides a summary of capital cost estimates associated with the upgrading of 46 kV  
11 transmission lines for supply to Wabush and Labrador City.

**Table 1: 46 kV Supply Summary Estimate (\$ million)**

<b>Scenario</b>	<b>2021</b>
Scenario 1: Baseline Forecast	1.4
Scenario 2: Baseline Forecast with FLK Supply Case	7.6
Scenario 3: Sensitivity Forecast	1.8
Scenario 4: Sensitivity Forecast with FLK Supply Case	7.7

12 Wabush Substation is on a radial system where its only source of supply is via 46 kV  
13 Transmission Line L36. An additional option to improve reliability and provide firm 46 kV supply  
14 for the residential Wabush load would be to install a second 46 kV transmission line connecting  
15 Wabush Substation to WTS. The additional capital cost for this option is estimated to be \$3.5  
16 million.

## **Appendix A**

### Description of Alternatives



1 The following sections summarize the preliminary scope for alternatives to provide upgrades to  
 2 the 46 kV transmission lines for supply to Wabush and Labrador City.

3

4 **Scenario 1: Baseline Forecast**

5 In this scenario, 46 kV line upgrades are required to provide firm 46 kV supply without  
 6 transmission line overload conditions. This requires reconductoring L32, L33, and L40 with  
 7 559.5 AAC Darien conductor.

8

9 Refer to Figure A1 for a load flow plot of the existing system configuration.

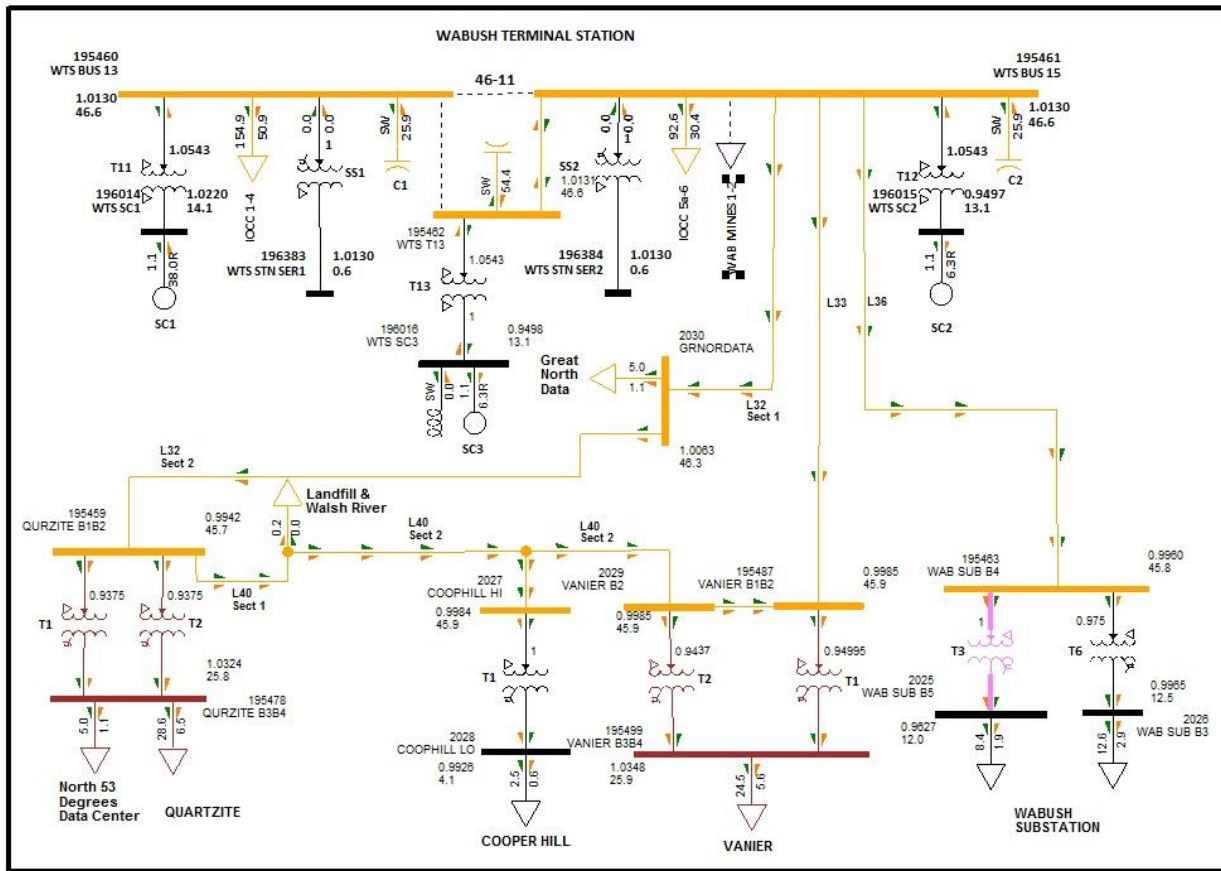

Figure A1: Baseline Forecast

1 The following is a summary of the work involved with this alternative:

- 2 • L32 Sections 1 and 2 are assumed to be 477 ASC conductor with a design conductor  
3 temperature of 50°C. Required work to reductor both sections with 559.5 AAAC  
4 Darien with a designed conductor temperature of 75°C;
- 5 • L40 Section 1 is assumed to be 266.8 ACSR Partridge conductor with a design conductor  
6 temperature of 50°C. Required work to reductor this section with 559.5 AAAC Darien  
7 with a designed conductor temperature of 75°C; and
- 8 • L33 is assumed to be 477 ACSR Pelican conductor with a design conductor temperature  
9 of 50°C. Required work to reductor this line with 559.5 AAAC Darien with a designed  
10 conductor temperature of 75°C.

11

## 12 **Scenario 2: Baseline Forecast with Flora Lake Supply Case**

13 This scenario calls for the construction of three new 46 kV distribution lines from the proposed  
14 new FLK Terminal Station to Wabush Substation, Vanier Substation and Great North Data Tap.  
15 This will off load the existing WTS and provide a level redundancy of supply to the distribution  
16 system. It is desirable to keep the existing L32 Section 1, L33, as well as L36 in standby mode, to  
17 assist in contingency situations. This configuration requires the reductoring of L32 and L40.

18

19 Please refer to Figure A2 for a load flow plot of this proposed configuration.

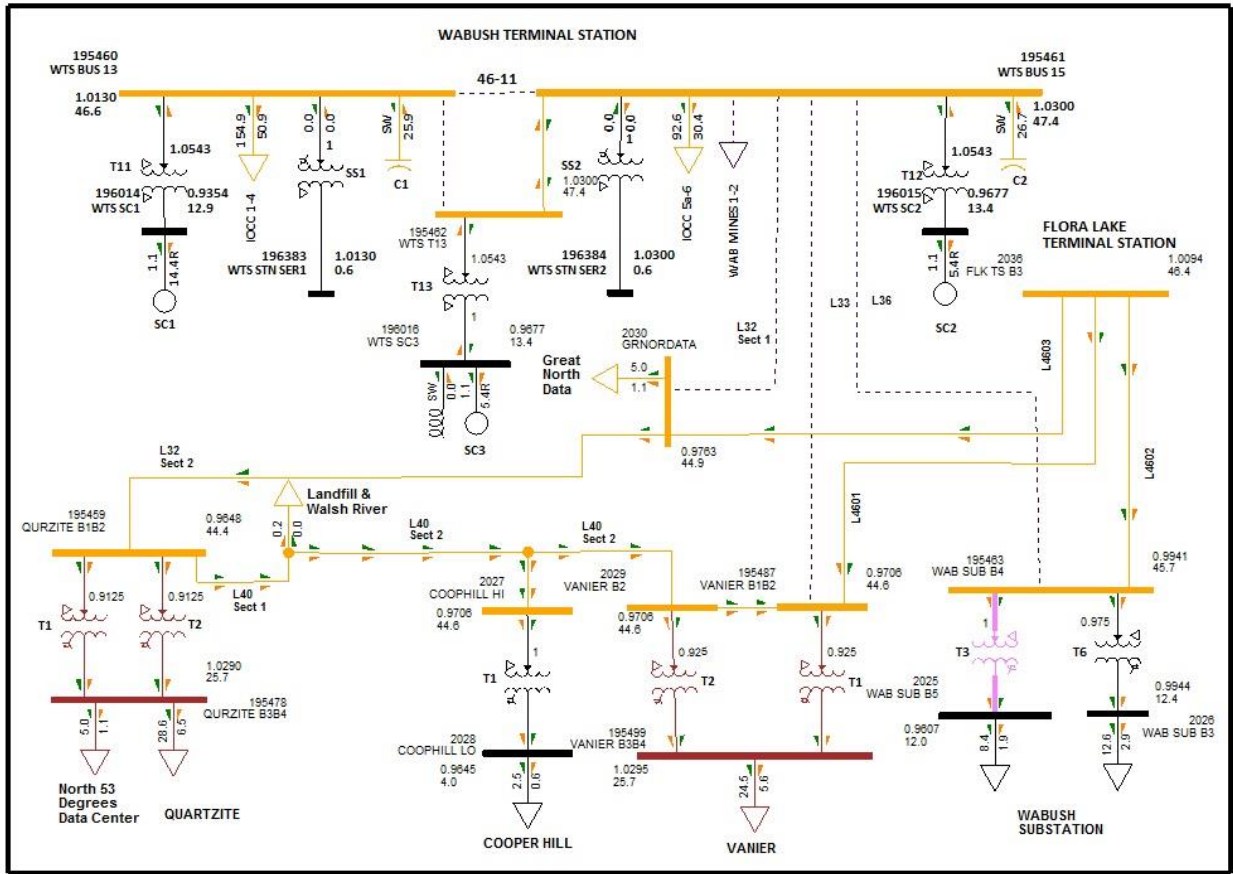

**Figure A2: Baseline Forecast with Flora Lake Supply Case**

- 1 The following is a summary of the work involved with this alternative:
- 2     • construction of 46 kV distribution line from FLK to Vanier Substation (L4601),
- 3         approximately 9 km. The line is to be constructed using 795 ACSR Drake conductor, with
- 4         a conductor operating temperature of 75°C;
- 5     • modification to Vanier Substation to include the following additions:
- 6         ○ new 46 kV line termination onto Bus B1;
- 7         ○ 1600 A SF6 breaker, complete with two sets of CTs;
- 8         ○ two motor operated disconnect switches and circuit breaker bypass switch;
- 9         ○ one line ground switch; and
- 10         ○ P&C, civil, and electrical works associated with tie in;

- 1       • construction of 46 kV distribution line from FLK to Wabush Substation (L4602),  
2           approximately 9 km. The line is to be constructed using 795 ACSR Drake conductor, with  
3           a conductor operating temperature of 75°C;
- 4       • modification to Wabush Substation to include the following additions:
  - 5           ○ new 46 kV line termination onto Bus B4;
  - 6           ○ 1600 A SF6 breaker, complete with two sets of CTs;
  - 7           ○ two motor operated disconnect switches and circuit breaker bypass switch;
  - 8           ○ one line ground switch; and
  - 9           ○ P&C, civil, and electrical works associated with tie in;
- 10      • construction of 46 kV distribution line from FLK to Great North Data Tap (L4603),  
11           approximately 7 km. The line is to be constructed using 795 ACSR Drake conductor, with  
12           a conductor operating temperature of 75°C. This line would tie into existing line L32  
13           Section 2;
- 14      • construction of box structure at Great North Data Tap for termination of new 7 km line.  
15           Structure to include manual transfer switch to enable transfer of source from new line  
16           or Section 1 of L32 to the load side, Section 2 of L32;
- 17      • L32 Section 2 is assumed to be 477 ASC conductor with a design conductor temperature  
18           of 50°C. Required work to uprate the design conductor temperature to 85°C for this  
19           section, this temperature rating is required due to N-1 contingency event;
- 20      • L40 Section 1 is assumed to be 266.8 ACSR Partridge conductor with a design conductor  
21           temperature of 50°C. Required work to uprate the design conductor temperature to  
22           75°C for this section;

23

### 24 **Scenario 3: Sensitivity Forecast**

25 In this scenario, line upgrades are required to avoid thermal overloading of lines. The  
26 reconductoring of sections of L32, L33, L36, and L40 with 795 ACSR Drake conductor was  
27 determined to avoid the overload conditions.

1 A load flow plot of this scenario is provided in Figure A3, below.

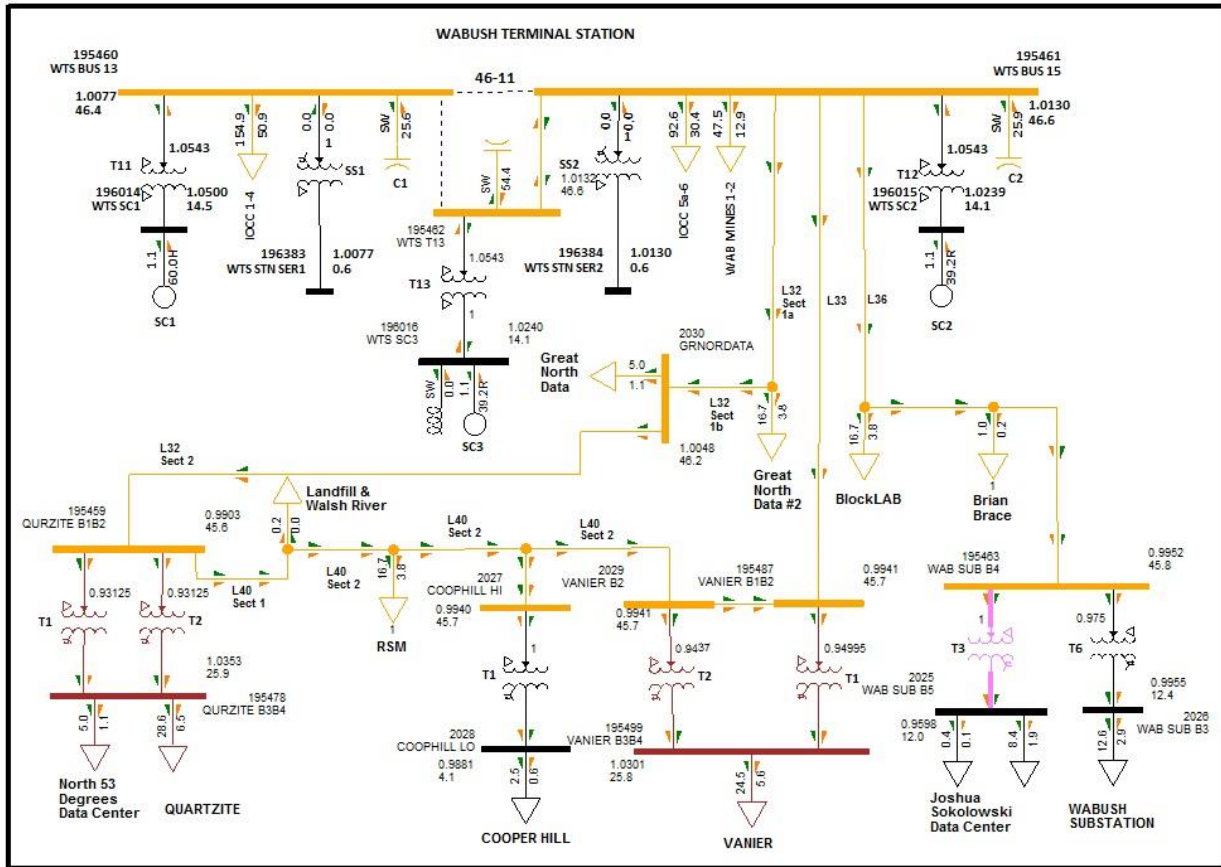

**Figure A3: Status Quo – with Data Centres**

2 The following is a summary of the work involved with this alternative:

- 3 • L32 Section 1a is to be reconducted with 795 ACSR Drake with a designated conductor
- 4 temperature of 100°C, this temperature rating is required due to N-1 contingency event;
- 5 • L32 Sections 1b and 2 are to be reconducted with 795 ACSR Drake with a designed
- 6 conductor temperature of 75°C;
- 7 • L33 is to be reconducted with 795 ACSR Drake with a designed conductor
- 8 temperature of 100°C, this temperature rating is required due to N-1 contingency event;
- 9 • L36 is to be reconducted with 795 ACSR Drake with a designed conductor
- 10 temperature of 75°C; and

- 1 • L40 Sections 1 and 2 are to be reconducted with 795 ACSR Drake with a designed
- 2 conductor temperature of 75°C.

3

4 **Scenario 4: Sensitivity Forecast with Flora Lake Supply Case**

5 This alternative calls for the construction of three new 46 kV distribution lines from the  
 6 proposed new FLK Terminal Station to Wabush Substation, Vanier Substation and Great North  
 7 Data Tap. This will off load the existing Wabush Terminal Station and provide a level  
 8 redundancy of supply to the distribution system. It is desirable to keep the existing L32 Section  
 9 1, L33, as well as L36 in standby mode, to assist in contingency situations. To avoid overload  
 10 conditions, L32 and L40 require reconductoring with 795 ACSR Drake conductor.

11

12 Please see Figure A4 for a load flow plot of this proposed configuration.

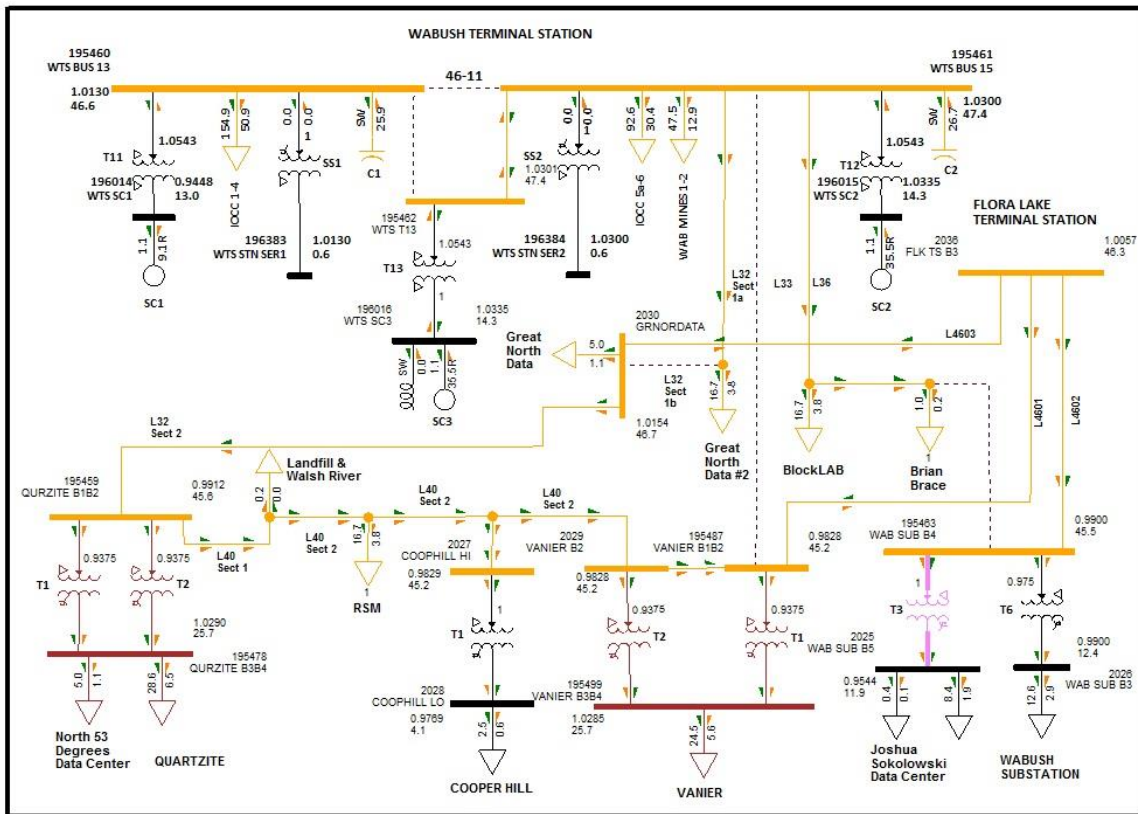

**Figure A4: Flora Lake Terminal Station 46 kV – with Data Centres**

1 The following is a summary of the work involved with this alternative:

- 2 • Great North Data Center No. 2 will remain connected to WTS 46 kV bus B15 via the  
3 existing 46 kV line L32 Section 1a. Purchase of a disconnect switch with a ground switch  
4 is required, to be installed approximately 0.225 km from the WTS to provide an isolation  
5 point for the remaining (non-energized) portion of L32 Section 1b.
- 6 • BlockLab and Brian Brace Data Centers will remain connected to WTS 46 kV bus B15 via  
7 the existing 46 kV line L36. Purchase of a disconnect switch with a ground switch to be  
8 installed approximately 0.2 km from the WTS to provide an isolation point for the  
9 remaining (non-energized) portion of L36.
- 10 • construction of 46 kV distribution line from FLK to Vanier Substation (L4601),  
11 approximately 9 km. The line is to be constructed using 795 ACSR Drake conductor, with  
12 a conductor operating temperature of 75°C .
- 13 • modification to Vanier Substation to include the following additions:
  - 14 ○ new 46 kV line termination onto Bus B1;
  - 15 ○ 1600 A SF6 breaker, complete with two sets of CTs;
  - 16 ○ two motor operated disconnect switches and circuit breaker bypass switch;
  - 17 ○ one line ground switch; and
  - 18 ○ P&C, civil, and Electrical works associated with tie in;
- 19 • construction of 46 kV distribution line from FLK to Wabush Substation (L4602),  
20 approximately 9 km. The line is to be constructed using 795 ACSR Drake conductor, with  
21 a conductor operating temperature of 75°C;
- 22 • modification to Wabush Substation to include the following additions:
  - 23 ○ new 46 kV line termination onto Bus B4;
  - 24 ○ 1600 A SF6 breaker, complete with two sets of CTs;
  - 25 ○ two motor operated disconnect switches and circuit breaker bypass switch;
  - 26 ○ one line ground switch;
  - 27 ○ P&C, civil, and Electrical works associated with tie in;

- 1       • construction of 46 kV distribution line from FLK to Great North Data Tap (L4603),  
2       approximately 7 km. The line is to be constructed using 795 ACSR Drake conductor, with  
3       a conductor operating temperature of 90°C, this temperature rating is required due to  
4       N-1 contingency event. This line would tie into existing line L32 Section 2;  
5       • construction of box structure at Great North Data Tap for termination of new 7 km line.  
6       Structure to include manual transfer switch to enable transfer of source from new line  
7       or Section 1 of L32 to the load side, Section 2 of L32;  
8       • L32 Section 2 is to be reconducted with 795 ACSR Drake with a designed conductor  
9       temperature of 85°C, this temperature rating is required due to N-1 contingency event;  
10      and  
11      • L40 Sections 1 and 2 are to be reconducted with 795 ACSR Drake with a designed  
12      conductor temperature of 75°C.







## **Appendix E**

### Reliability Assessment of the 138kV lines Supplying Labrador East



# Reliability Assessment for the 138 kV Lines Supplying Labrador East

October 2018

*A Report to the Board of Commissioners of Public Utilities*



**Table of Contents**

1 Objective ..... 1

2 Asset Maintenance – Wood Pole Transmission Lines ..... 1

3 Design Criteria..... 1

4 Life Data Analysis ..... 2

5 Survival Probability in Future Years (Replacement Rate) ..... 3

    5.1 Pole Asset..... 4

    5.2 X-Arm Asset..... 4

6 Recommendations for Replacement Rate and Initial Costs ..... 5

7 Summary and Conclusions..... 5

**List of Appendices**

Appendix A: Unavailability and Expected Energy Not Supplied (“EENS”)

1 **1 Objective**

2 The purpose of this document is to provide a recommended plan of replacement of wood pole  
3 plant assets and estimate the planned maintenance outage duration to ensure that this is  
4 included in determining the unavailability of the L1301 and L1302, respectively. The document  
5 will also address the specific request as stated in Board Order No. P.U. 9(2018)<sup>1</sup> “... iv) the  
6 condition of existing assets and an estimate of remaining life...”

7  
8

9 **2 Asset Maintenance – Wood Pole Transmission Lines**

10 Newfoundland and Labrador Hydro initiated a proactive Wood Pole Line Management  
11 (“WPLM”) program 15 years ago to address four specific items as follows:

- 12 1) Inspect poles and associated line components such as conductor, hardware and  
13 insulators;
- 14 2) Treat all poles;
- 15 3) Develop and implement an electronic data collection system to facilitate field data  
16 collection and subsequent data analysis; and
- 17 4) Make data based, optimized decisions to rehabilitate, or replace poles and associated  
18 hardware.

19

20 The aim of the program is to ensure that deteriorated poles are identified and retreated for life  
21 extension, and identify in a timely manner poles requiring replacement before failures occur in  
22 service, thereby avoiding more expensive repairs, service outages, and danger to line workers.

23

24 **3 Design Criteria**

25 The basic supporting structures in this line are wood pole braced H-frame single circuit  
26 configuration type. Two continuous overhead shield wires were installed for approximately 1.5

---

<sup>1</sup> Board Order No. P.U. 9(2018), page 9, lines 34 to 35.

1 to 3 kilometers out from Churchill Falls Substation and 1.5 kilometers approaching Happy Valley  
2 Substation.

3  
4 Traditional design load for a high voltage (HV) overhead line is based on the appropriate  
5 selection of a return period. Typically, line of this voltage class will be designed for a 50-year  
6 return period. Because the importance of the line at the time was identified as somewhat  
7 lower,<sup>2</sup> the design return period selected was 25 years. However, the line has survived for 42  
8 years. The line is also designed to meet *CSA C22.3 - 1970 Specification - for Grade 1*  
9 *Construction - Under Heavy Loading Conditions*.

10

#### 11 **4 Life Data Analysis**

12 Based on the current projection (solid red curve), the data used in this analysis indicates that  
13 the expected mean life for the L1301/L1302 wood pole plant asset is approximately 103 years  
14 (Figure 1), which is significantly higher than the conventional economic life of 40 years  
15 historically used in the industry.<sup>3</sup> The typical Iowa curve assumes an expected asset life of 50  
16 years. Similarly, the expected mean life for the X-arm shows that the asset life is 63 years  
17 (Figure 2).

---

<sup>2</sup> L1301 was originally a temporary construction power line during the construction of the Gull Island Project in the mid-1970s.

<sup>3</sup> M. Mankowski, M. E. Hansen, and J. Morrell "Wood Pole Purchasing, Inspection and Maintenance: A Survey of Utility Practices", *Forest Product Journal*, Vol. 52, No. 11/12, 2002, p.43-50.



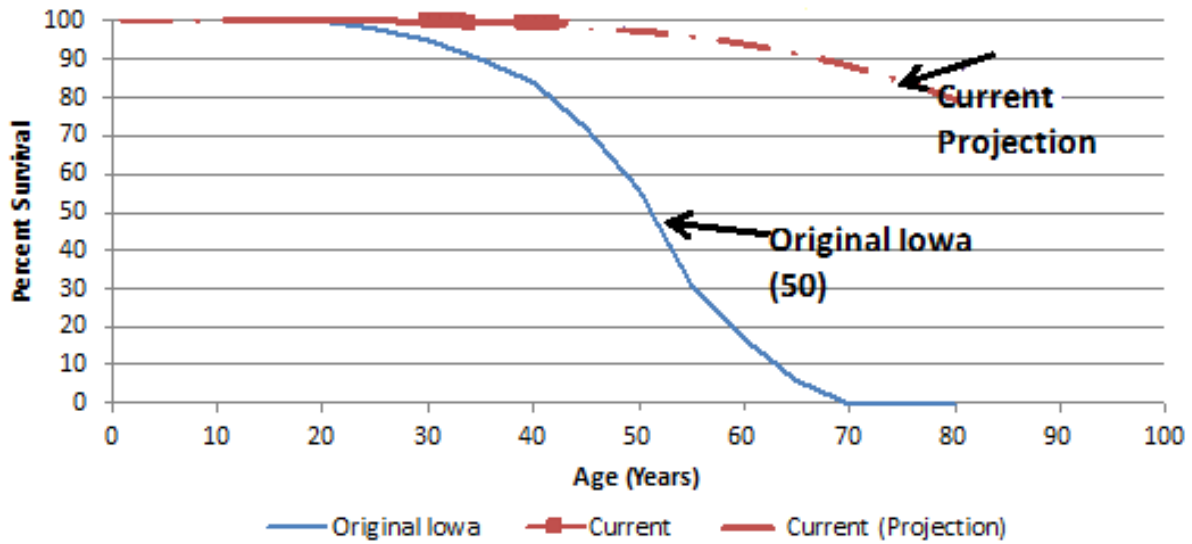

Figure 1: L1301 – Survival Plot for Pole Plant Asset

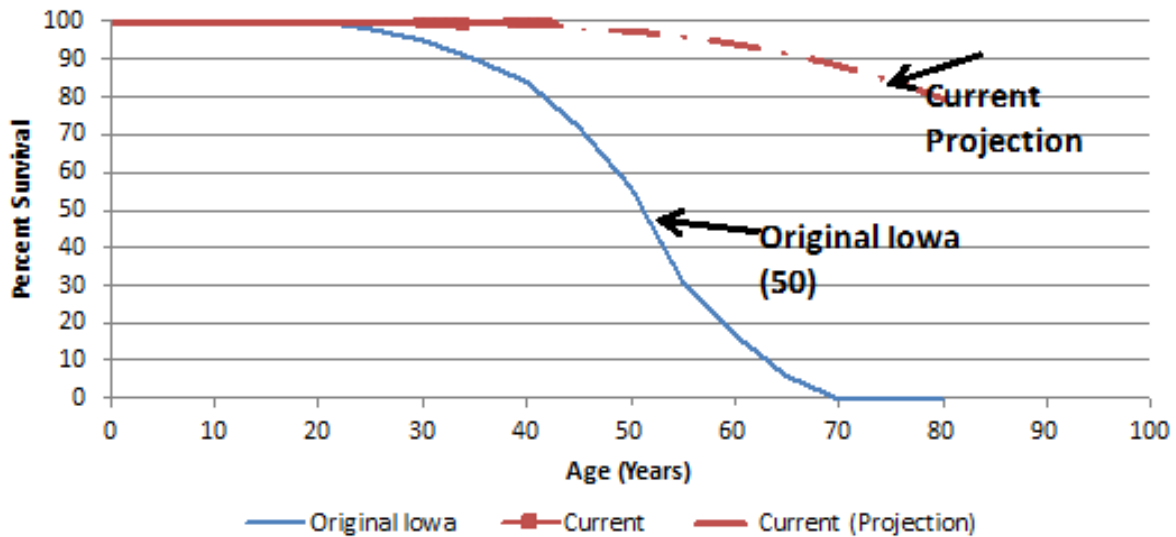

Figure 2: L1301 – Survival Plot for X-arm

1 **5 Survival Probability in Future Years (Replacement Rate)**

2 Based on Figure 1 and Figure 2, the probability of replacement in the future years was  
 3 calculated as conditional probability given that both pole plant assets and X-arms have survived  
 4 for 42 years. The results are shown in Figures 4 and 5, respectively.

1 5.1 Pole Asset

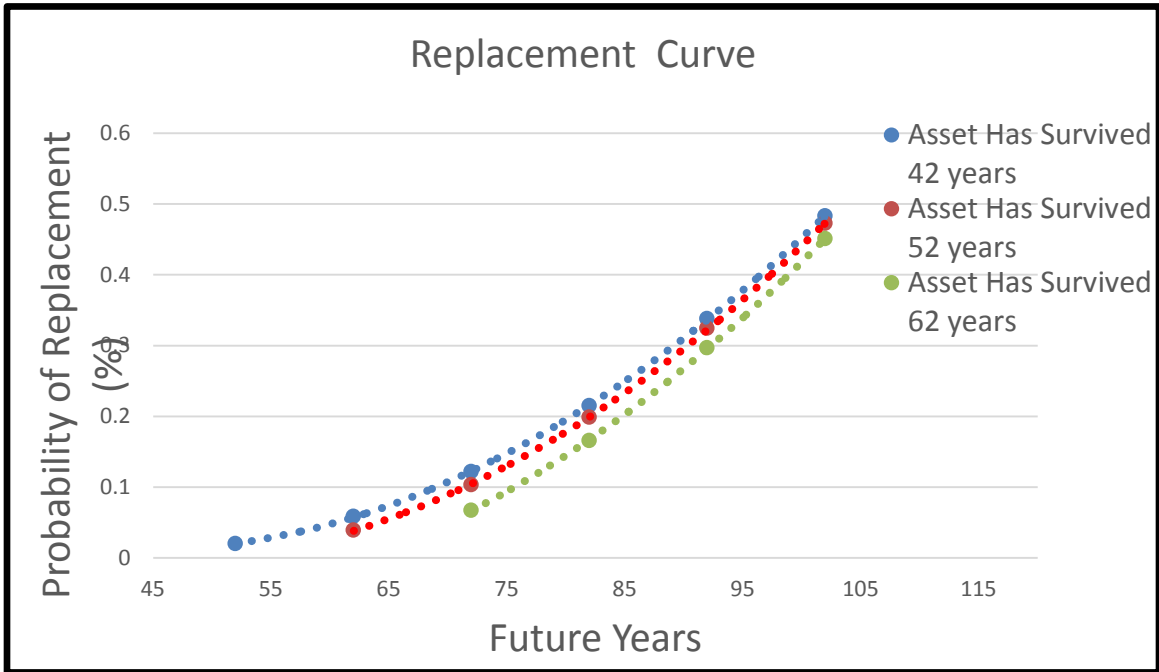

Figure 3: Replacement Probability of the Pole Plant Assets<sup>4</sup>

2 5.2 X-Arm Asset

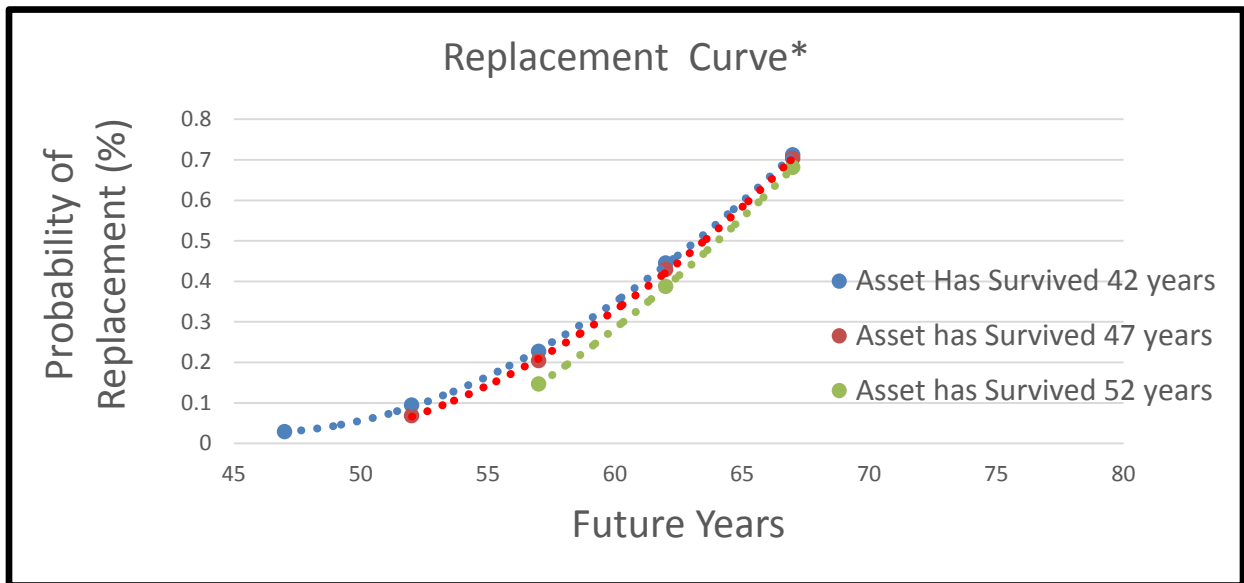

Figure 4: Replacement Probability of the X-Arm Plant Assets<sup>5</sup>

<sup>4</sup> Given that the asset has survived a T-year period.

<sup>5</sup> Given that the Asset Has Survived a T-year period.

1 **6 Recommendations for Replacement Rate and Initial Costs**

2 Based on the asset life data analysis, it is estimated from Figure 3 that the replacement rate of  
3 the pole plant asset for L1301 for the next 20-year planning horizon would be 0.30 percent per  
4 year given that it has survived for 42 years of operation. Similarly, this replacement rate for the  
5 X-arm asset would be 2.3 percent per year (Figure 4). Accordingly, the annualized cost data for  
6 replacement of poles and X-arms and inspection cost are included in the cost benefit analysis.

7

8 **7 Summary and Conclusions**

9 Results of the data analysis clearly demonstrate that the expected life of the wood pole for  
10 L1301 is estimated as 103 years while the X-arm is estimated as 63 years. The line has survived  
11 42 years of operations. The overall pole replacement rate per year is well below the published  
12 industry data. Based on the current rejection rate, it is estimated that Hydro may be required to  
13 replace 0.30 percent of pole plant asset per year for the planning horizon considered in this  
14 study. For the X-arm, this replacement rate would be 2.3 percent per year. Planned  
15 maintenance outage duration for L1301 is estimated to be seven days in each year of future  
16 operation to support this replacement rate and the number of poles and X-arms that need to  
17 be replaced per year. The planned maintenance outage duration should be pro-rated for L1302  
18 in terms of line length. This maintenance outage data is provided in Appendix A of this  
19 document for unavailability and expected energy not supplied (“EENS”) calculations. Annualized  
20 cost of replacement of pole plant assets and X-arms and inspection costs are provided in the  
21 cost benefit section and are developed based on the information provided in this section. This  
22 cost data is later used in the cost benefit analysis presented in the main section of this report.

**Appendix A**

Unavailability and Expected Energy Not Supplied (“EENS”)

1 **Availability Calculations for Options 1 and 2**

2 **Option 1**

- 3 The proposed plan for Alternative 1 is to offload L1301/L1302 under peak conditions through  
4 the interruption of customer load and the operation of back-up generation on the Happy  
5 Valley–Goose Bay system.

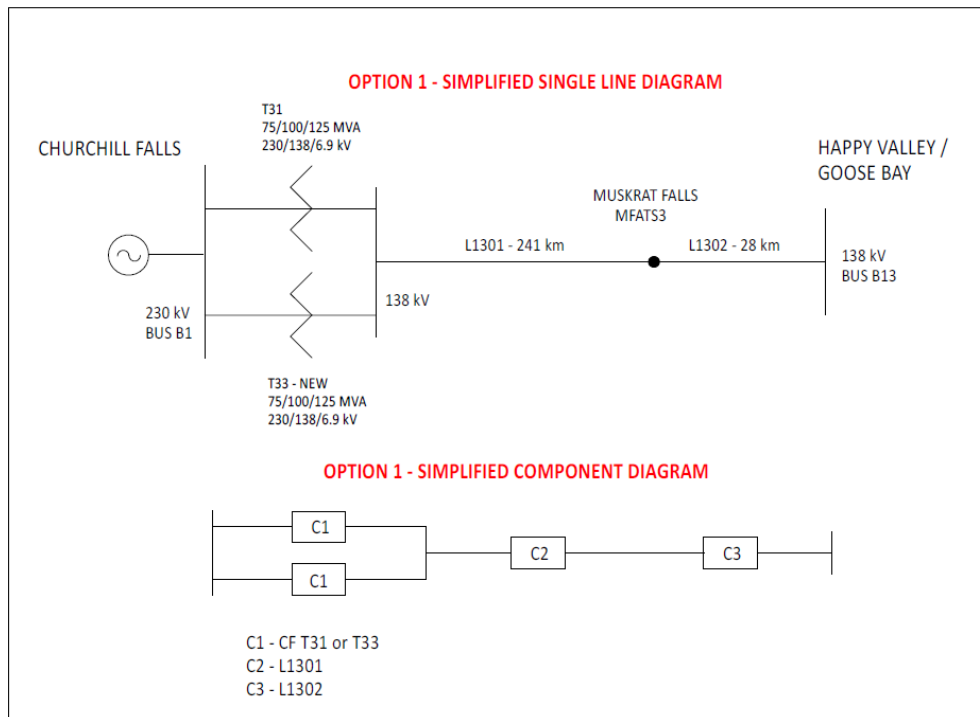

**Figure A1: Option 1 – Simplified Single-Line/Component Diagram**

**Table A1: Option 1 – Component Unavailability**

<b>Sustained Outage Data</b>					
<b>Component</b>	<b>Description</b>	<b>Freq (f)</b>	<b>Mean Time to Repair (r)</b>		<b>Unavailability U (f × r)</b>
		<b>occur/year</b>	<b>(hours)</b>	<b>(Years)</b>	
C1	CF T31 or T33	0.1431	254.35	0.02904	0.00416
C2	L1301	2.1353 <sup>6</sup>	16.85	0.00192	0.00411
C3	L1302	0.2481 <sup>7</sup>	16.85	0.00192	0.00048

<b>Maintenance Outage Data</b>					
<b>Component</b>	<b>Description</b>	<b>Freq (f)</b>	<b>Mean Time to Repair (r)</b>		<b>Unavailability U (f × r)</b>
		<b>occur/year</b>	<b>(hours)</b>	<b>(Years)</b>	
C2	L1301	1	168 <sup>8</sup>	0.01918	0.01918
C3	L1302	1	19.52 <sup>9,10</sup>	0.00223	0.00223

1 Unavailability for Option 1 is derived by calculating the unavailability of the parallel  
2 combination of C1 and C1, in series with C2 in series with C3 as follows:

3  $U_{C1C1pa} = U_{C1} \times U_{C1} = 0.00416 \times 0.00416 = 0.0000173$

4  $U_{C2C3se} = U_{C2} + U_{C3} - U_{C2} \times U_{C3} = 0.004588$

5  $U_1 = U_{C1C1pa} + U_{C2C3se} - (U_{C1C1pa} \times U_{C2C3se}) = 0.00460$

6

7 (Unavailability of Option 1 without Maintenance Outage Included)

8 Unavailability due to Maintenance of L1301 (WPLM)  $U_{C2M} = \lambda \times r = 1 \times \frac{168}{8760} = 0.01918$

9 Unavailability due to Maintenance of L1302 (WPLM)  $U_{C3M} = \lambda \times r = 1 \times \frac{19.52}{8760} = 0.00223$

10 Unavailability of  $U_{C2} = U_{C2E} + U_{C2M} - U_{C2E} \times U_{C2M} = 0.00411 + 0.01918 - 0.00411 \times 0.01918 = 0.02321$

11 Unavailability of  $U_{C3} = U_{C3E} + U_{C3M} - U_{C3E} \times U_{C3M} = 0.00048 + 0.00223 - 0.00048 \times 0.00223 = 0.00270$

12  $U_{C2C3se} = U_{C2} + U_{C3} - U_{C2} \times U_{C3} = 0.02321 + 0.00270 - 0.02321 \times 0.00270 = 0.02579$

13  $U_1 = U_{C1C1pa} + U_{C2C3se} - (U_{C1C1pa} \times U_{C2C3se}) = 0.0000173 + 0.02579 - 0.0000173 \times 0.02579 = 0.0258$

14  $U_1 = 0.0258$  (Unavailability of Option 1)

<sup>6</sup> L1301 = (0.886 occurrences / 100km.a) × 241 km = 2.1353.

<sup>7</sup> L1302 = (0.886 occurrences / 100km.a) × 28 km = 0.2481.

<sup>8</sup> Outage data is derived from the Life Data Analysis.

<sup>9</sup> L1302 = (168 / 241km) × 28 km = 19.52.

<sup>10</sup> Outage duration for C3 is prorated based on line length.

1 **Option 2**

- 2 This project proposes tapping transmission line L1302 at the Muskrat Falls 138/25 kV Tap  
3 Station (“MFATS3”) and the addition of a 6 km segment of 138 kV wood pole transmission line  
4 constructed to the Muskrat Falls 315 kV Terminal Station (“MFATS2”).

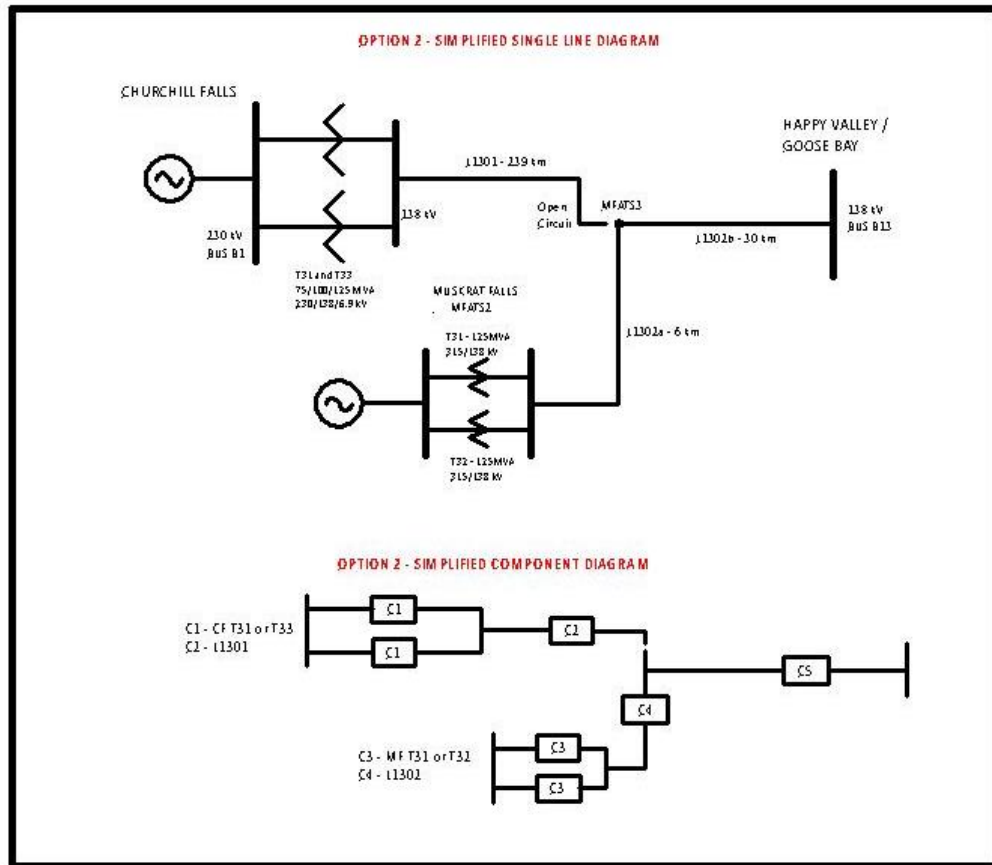

Figure A2: Option 2 – Simplified Single-Line/Component Diagram

**Table A2: Option 2 – Component Unavailability**

<b>Sustained Outage Data</b>					
<b>Component</b>	<b>Description</b>	<b>Freq (f)</b>	<b>Mean Time to Repair (r)</b>		<b>Unavailability</b>
		<b>occur/year</b>	<b>(hours)</b>	<b>(Years)</b>	<b>U ( f x r )</b>
C1	CF T31 or T33	0.1431	254.35	0.02904	0.00416
C2	L1301	2.11754 <sup>11</sup>	16.85	0.00192	0.00407
C3	MF T31 or MF T32	0.2020	477.0	0.05445	0.01100
C4	L1302a (6km)	0.05316 <sup>12</sup>	16.85	0.00192	0.000102
C5	L1302b (30km)	0.2658 <sup>13</sup>	16.85	0.00192	0.00051

<b>Maintenance Outage Data</b>					
<b>Component</b>	<b>Description</b>	<b>Freq (f)</b>	<b>Mean Time to Repair (r)</b>		<b>Unavailability</b>
		<b>occur/year</b>	<b>(hours)</b>	<b>(Years)</b>	<b>U ( f x r )</b>
C2	L1301 (239km)	1	166.9 <sup>14</sup>	0.0190	0.0190
C4	L1302a (6km)	N/A	N/A <sup>15</sup>	N/A	N/A
C5	L1302 (30km)	1	20.92 <sup>16</sup>	0.00239	0.00239

1 Unavailability due to Maintenance,  $C2M = \lambda \times r = 1 \times \frac{166.9}{8760} = 0.0190$

2 Unavailability due to Maintenance,  $C5M = \lambda \times r = 1 \times \frac{21.09}{8760} = 0.00241$

3

4 Option 2 unavailability is derived by calculating the unavailability of the combination of:

5 i) Parallel combination of C1 and C1, in series C2.

6  $U_{C1C1pa} = U_{C1} \times U_{C1} = 0.00416 \times 0.00416 = 0.0000173$

<sup>11</sup> L1301 = (0.886 occurrences / 100km.a) x 239 km = 2.11754.

<sup>12</sup> L1302a = (0.886 occurrences/100km.a) x 6 km = 0.05316.

<sup>13</sup> L1302b = (0.886 occurrences/100km.a) x 30 km = 0.2658.

<sup>14</sup> L1301 = (168/ 241km) x 239 km = 166.

<sup>15</sup> L1302a = (168/ 241km) x 6 km = N/A.

<sup>16</sup> L1302b = (168/ 241km) x 30 km = 20.92.



1 Adjusting the C2 unavailability due to maintenance

2 
$$U_{C2} = U_{C2E} + U_{C2M} - U_{C2E} \times U_{C2M} = 0.00407 + 0.0190 - 0.00407 \times 0.019 = 0.2301$$

3 
$$U_{C1C1paC2se} = U_{C1C1pa} + U_{C2} - U_{C1C1pa} \times U_{C2} = 0.0000173 + 0.2301 - 0.2301 \times 0.0000173 =$$
  
 4 0.02303

5

6 ii) Parallel combination of C3 and C3, in series C4.

7 
$$U_{C3C3pa} = U_{C3} \times U_{C3} = 0.011 \times 0.011 = 0.000121$$

8 
$$U_{C3C3paC4se} = U_{C3C3pa} + U_{C4} - U_{C3C3pa} \times U_{C4} = 0.000223$$

9

10 iii) Parallel combination of items I and ii in series with C5.

11 
$$U_{iUiiipa} = U_i \times U_{ii} = 0.02303 \times 0.000223 = 0.00000513$$

12

13 Adjusting the C5 unavailability due to maintenance

14 
$$U_{C5} = U_{C5E} + U_{C5M} - U_{C5E} \times U_{C5M} = 0.00051 + 0.00239 - 0.00051 \times 0.00239 = 0.00290$$

15 
$$U_{iUiiipaC5se} = U_{iUiiipa} + U_{C5} - U_{iUiiipa} \times U_{C5} = 0.00000513 + 0.00290 - 0.00000513 \times$$
  
 16 0.00290 = 0.00290

17

18 
$$U_2 = U_{iUiiipa} + U_{C5} - (U_{iUiiipa} \times U_{C5}) = 0.00290$$

19

20 
$$U_2 = 0.00290 \text{ (Unavailability of Option 2)}$$

1 **Expected Energy Not Supplied (“EENS”)**

**Table A3: Unavailability/EUE Comparison of Options**

<b>Interconnection Option</b>	<b>Calculated Unavailability (U)</b>	<b>Calculated Expected Unserved Energy (MWh)<sup>17</sup></b>
1	0.0258	8,570
2	0.00290	960

2 Based on the revised analysis, it appears that the unavailability is increased by fivefold and so as  
3 the EENS when one considers the planned maintenance outage in the unavailability analysis  
4 (0.00406 for Option 1 and 0.00051 for Option 2 without planned maintenance outage). Also,  
5 the unavailability of Option 2 appears to be approximately one tenth of that of the one  
6 computed for Option 1 indicating that Option 2 is significantly reliable compared to Option 1.

7

8 A time history plot of the EENS for the planning horizon can be created by multiplying the  
9 energy forecast data for Happy Valley-Goose Bay by the numbers in Table A3. Once this is  
10 developed, the cost of unsupplied energy can be determined and the value of EENS can be  
11 estimated over the planning horizon. A separate analysis not shown here was carried out using  
12 the sustained outage data for L1301 and L1302 from Churchill Falls database. The results  
13 showed that the unavailability data for Options 1 and 2 were comparable to those obtained  
14 from CEA data presented in Table A3.

---

<sup>17</sup> Based upon the Happy Valley-Goose Bay 2020 annual energy requirement of 332 GWh.